

775G

Off-Highway Truck



Engine (Tier 4 Final)

Engine Model	Cat® C27 ACERT™	
Gross Power – SAE J1995	615 kW	825 hp
Net Power – SAE J1349	572 kW	768 hp

Engine (Tier 2 Equivalent)

Engine Model	Cat® C27 ACERT™	
Gross Power – SAE J1995	615 kW	825 hp
Net Power – SAE J1349	584 kW	783 hp

Weights – Approximate (Tier 4 Final)

Maximum Gross Vehicle Weight	111 812 kg	246,503 lb
------------------------------	------------	------------

Weights – Approximate (Tier 2 Equivalent)

Maximum Gross Vehicle Weight	111 812 kg	246,503 lb
------------------------------	------------	------------

Operating Specifications (Tier 4 Final)

Nominal Payload Class (100%)	64.0 tonnes	70.5 tons
Maximum Working Payload (110%)	70.3 tonnes	77.5 tons
Not to Exceed Payload (120%)*	76.7 tonnes	84.6 tons
Body Capacity – SAE 2:1	42.23 m ³	55.23 yd ³

Operating Specifications (Tier 2 Equivalent)

Nominal Payload Class (100%)	64.6 tonnes	71.3 tons
Maximum Working Payload (110%)	71.1 tonnes	78.3 tons
Not to Exceed Payload (120%)*	77.5 tonnes	85.5 tons
Body Capacity – SAE 2:1	42.23 m ³	55.23 yd ³

• Capacity with dual slope body – no liner.

* Refer to the Caterpillar 10/10/20 Payload Guidelines for maximum gross machine weight limitations.

Features

G Series Customer Requirements

- meet safety and regulatory requirements
- machine available when scheduled to work
- performance that promotes low owning and operating costs
- provide an operating environment that enhances productivity

G Series Quality

G Series is backed by comprehensive virtual validation, prototype testing and 33,000 hours of work in the hands of customers prior to production.

G Series Performance

The 775G has 5% more power and new transmission controls that convert power to work with automotive-quality shifting and comfort.

G Series Economics

G Series introduces new fuel saving strategies that meet customers' job site conditions and needs, and allows simple and easy servicing.

G Series Safety

With improved designs that impact braking, traction control, visibility and egress, G Series is setting new standards of safety in this size class of truck.

Sustainable Designs

The 775G reaches new levels of sustainability using less fuel, producing few emissions and reducing sound levels by 50% for the operator.

Contents

The Operator Experience.....	3
Performance	4
Fuel Saving Strategies	5
Structural Integrity.....	6
Power Train.....	7
Emission Controls.....	8
G Series Body Strategy.....	9
Machine Information and Monitoring	10
Serviceability.....	12
Safety	14
Sustainability	15
Specifications.....	16
Standard Equipment.....	29
Optional Equipment.....	31



Caterpillar is pleased to introduce to you the 775G off-highway truck. You may be asking how, after 40 years of building trucks, Caterpillar has improved this product's ability to support your business.

G Series has been designed and manufactured using the latest quality control technologies; both virtual and hands on. This product has over 30,000 hours of proven performance in the hands of customers prior to production, all of which ensures the truck delivered to your yard is ready to work, reliably and dependably.

In addition to quality, Cat G Series trucks will lower your costs with seven different ways to help you conserve fuel. We offer you two customizable fuel economy modes that will let you choose the level of savings. With Cat G Series trucks in your haul fleets, you can be more productive, spend less time on maintenance, and support the environment with new levels of eco performance. Your crew will appreciate all the new comfort and conveniences in our updated cab. Simply put, Cat G Series trucks can and will make a positive difference to both your business and people.

The Operator Experience

Best in the industry

Operator Confidence

- Ergonomics that put controls within reach
- New braking performance and design
- Engine braking option for Automatic Retarding Control
- Improved retarder lever ergonomics and activation
- Mirror options including heated and concave
- Seating that adjusts to individual needs with suspension and three point harness
- Seating for trainer or folds up for additional work space
- In-cab fluid level monitoring
- Machine event warnings and messaging

Operator Comfort

- Industry leading access system, with low effort climbing and three points of contact
- Exceptionally smooth machine performance
- A 50% noise reduction from the F Series cab
- Automatic temperature control
- Cat Comfort Seat is Series III with vibration reduction
- Electric window – left side
- New foot rest addition

Operator Safety

- Emergency egress out right side, hinged window
- Enhanced ROPS/FOPS design in cab structure
- Secondary braking
- Ground level daily checks
- TKPH/TMPH Tire Monitoring System
- Warnings via Advisor display
- Body up speed limited, can be set by customer
- New tread plate design on access system; better traction; sheds material from walkways





Performance

Intelligent application of power and technology

Power

The Cat C27 ACERT diesel engine is delivering 5% additional power to the drive train. As a result, new and more robust drive train components, including a larger drive shaft and differential gears have been designed to handle the power.

Technology

G Series introduces a new planetary powershift transmission control strategy called APECS. APECS takes the benefits of ECPC (Electronic Clutch Pressure Control) and adds part throttle shifting and torque shift management. The result is exceptionally smooth automotive-type shifting and ride quality. APECS also retains torque and momentum through the shifts; increasing performance on grades. The result is quick starts from a stand still and exceptionally smooth shift and ride quality.

Intelligence

A new Traction Control System is now steering sensitive to differentiate between tire spin or high speed turns. The system now uses the hydraulically applied service brakes (vs. spring applied secondary brakes) allowing it to engage sooner and at lower speeds. G Series TCS modulates power and braking instantaneously between the two wheel groups, allowing a more appropriate response to ground conditions, and returning the truck to solid footing much sooner.

Fuel Saving Strategies

Solutions that support your lowest cost per ton

Fuel Saving Strategies

- **Standard Economy Mode** – G Series can adjust engine power based on your individual needs. With this feature, fuel savings are achieved by reducing power between 0.15 to 15 percent.
- **Adaptive Economy Mode** – New for G Series – requires a baseline for production from you. As the truck goes through the haul cycle, it constantly evaluates your baseline against opportunities to reduce power and save fuel. It's fully automatic with no special operation required.
- **Speed Limiting** – while you can continue to gear limit your G Series trucks, Caterpillar offers another alternative you can utilize which is the new speed limiting feature. Speed limiting allows the truck to travel in its most fuel efficient gear.
- **Auto Neutral Idle** – as the 775G waits for the loader or crusher while idling in a forward gear, the transmission will automatically slip into a neutral state to avoid stalling the torque converter and raising engine rpm. As soon as the operator releases the brake or applies throttle, the truck is instantly back in the forward gear.
- **Engine Idle Shutdown** – when your G Series truck is in park and idles for more than a preset time which is set by the customer, the truck will initiate engine shutdown to conserve fuel. This feature can be time adjusted or turned on or off according to your specific needs.



Structural Integrity

Designed for years of off-road service

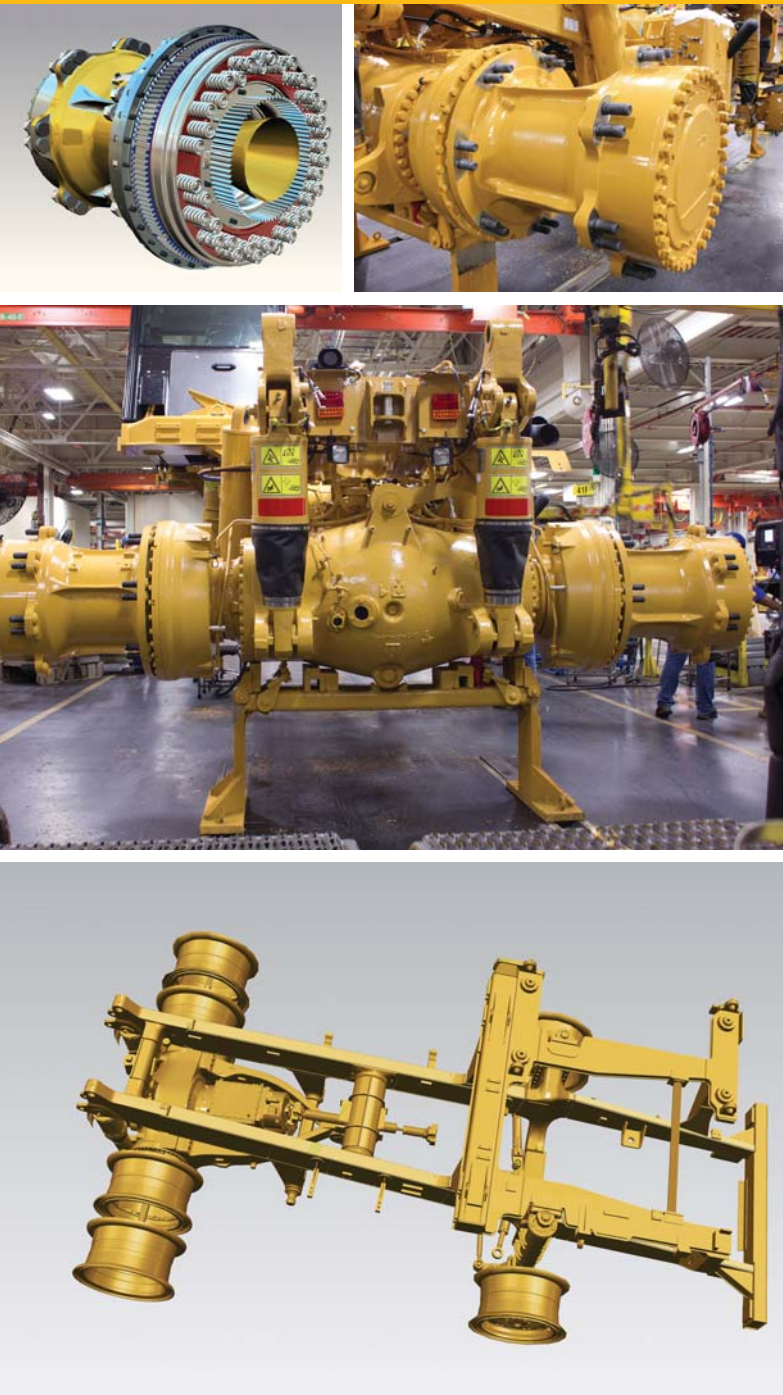

New Brake Design

G Series has increased the number of springs in its brake design. This increases the force available to disengage the brakes ensuring clearances are maintained, reducing wear. A new brake wear indicator can be found on the rear wheels to help you monitor brake life.

Extending brake life can also be achieved by choosing the optional Cat Engine Brake. This Caterpillar design works in conjunction with the automatic retarder control (ARC) to slow the machine.

Rear Wheel Steel Spindles

G Series wheel spindles are solid steel and interchangeable from one side to the other extending their useful service life.

Inverted Rear Cylinders

For G Series, Caterpillar has inverted the rear suspension cylinders to better protect the rods, keeping them cleaner for longer durations.

Structures

Updated castings, improved bolted joints and a larger rear axle have matched the chassis design with the higher power ratings and performance specifications of the truck.

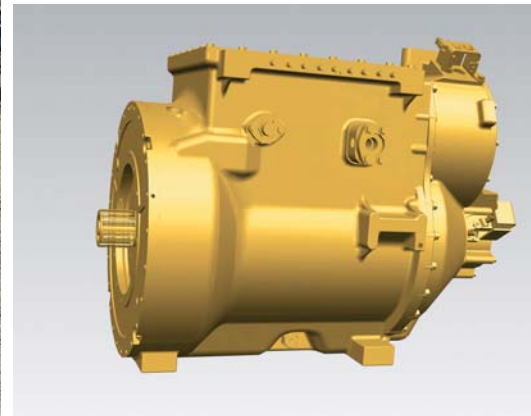
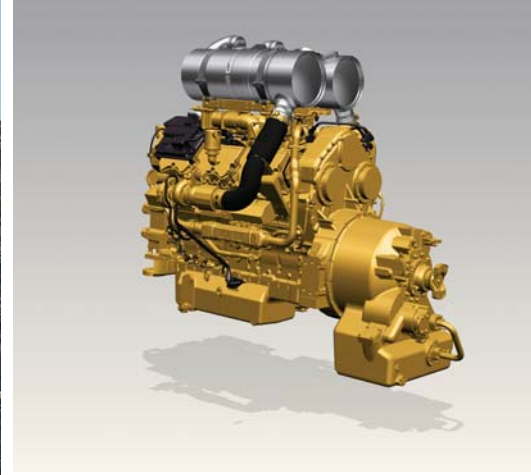

Power Train

Application specific designs for industry leading performance

Engine

G Series trucks retain the highly productive and reliable Cat C27 ACERT diesel engine.

- With a 5% boost in power, the C27 is delivering higher torque for work.
- With the precision and responsiveness of Cat MEUI™ fuel injectors and electronic controls, the C27 accurately controls fuel, emissions and performance.
- The C27 is carefully balanced with vibration controls that reduce noise and protect against unnecessary wear.
- The C27 is cooled by either a demand fan (standard on Tier 4 Final) or conventional cooling fan.

Planetary Powershift Transmission

With new control strategies, this proven transmission is better than ever. Its new features include gear changes as smooth as an automobile and more torque through the shifts getting the truck up to speed faster and negotiating grades quicker.

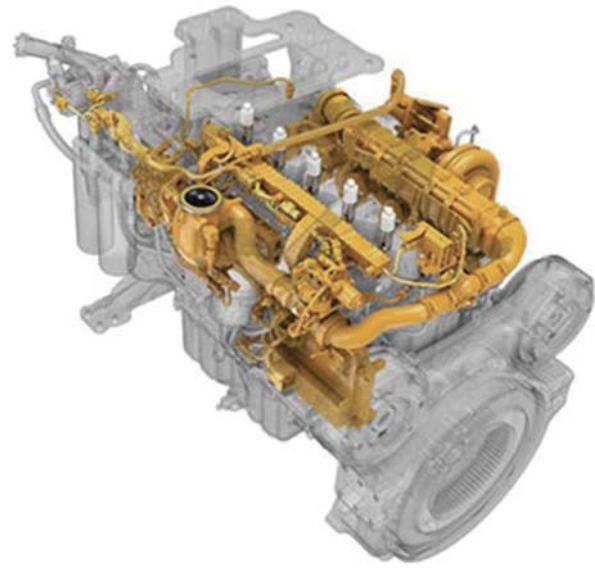

Emission Controls

Major improvements for air quality using simple to use, reliable solutions

Tier 4 Final Emission Controls

Caterpillar offers a simple and robust U.S. EPA Tier 4 Final passive solution. Other than normal maintenance, this system requires no additional input or intervention by the operator.

NO_x Reduction

Supported by cleaner burning, ultra-low sulfur diesel fuel and low ash oils, Caterpillar uses its engine-mounted NO_x Reduction System (NRS) Technology to cool combustion chamber temperatures to control NO_x production.

PM Reduction

Located on top of the engine are two diesel oxidation catalysts (DOC), one for each exhaust outlet. These diesel oxidation catalysts reduce particulate emissions.

Tier 4 Final C27 ACERT engines are equipped with MEUI-C injectors. These injectors offer exceptional fuel atomization for engines running at slower speeds. MEUI-C injectors have an improved fuel shut off response time, saving fuel and reducing emissions.

For customers purchasing trucks outside of North America, Caterpillar offers emission controls similar to those used for Tier 2/Stage II regulations.

G Series Body Strategy

Bodies to meet your application and material needs

Caterpillar has made it easier to get the right body for your materials and job site needs.

The 775G has a Dual Slope, a Flat Floor and a Quarry body option.

Our base Flat Floor and Dual Slope bodies have a 20 mm (0.78 in), 400 BNH steel floor. Adding a steel or rubber liner is optional for those applications when you are working with highly abrasive or high impact materials.

Our Quarry body has a 25 mm (0.98 in), 400 BNH steel floor and is designed specifically for limestone applications without additional liners.

Two additional liner packages for the Flat Floor and Dual Slope bodies are available from the factory:

- A 16 mm (0.62 in), 400 BNH steel liner
- A 102 mm (4.01 in) rubber liner
- Sideboards are optional from the factory for the flat floor or dual slope bodies.
- A body heat diverter kit is optional for both dual slope and flat floor bodies

You will find additional body specifications at the back of this document.

Caterpillar's 10/10/20 Policy

Caterpillar's 10/10/20 Payload Guidelines are in place to help you maximize component life and the availability of your truck. Your Cat dealer can further explain the 10/10/20 policy. For optimum body life, Caterpillar recommends that 110% payloads occur no more than 10% of the time and that the average of all loads equal the nominal payload. Payloads in excess of 120% of nominal exceed the truck's design parameters.

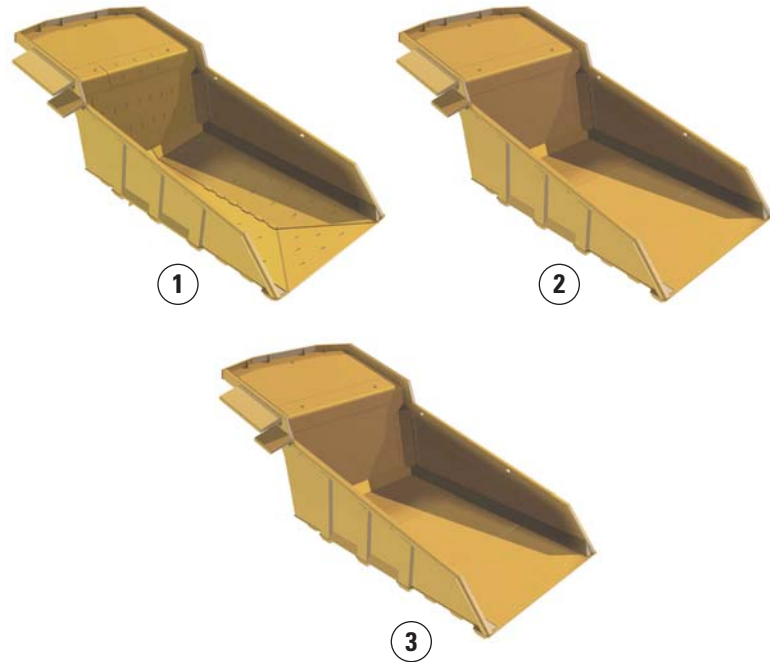

1) Dual Slope 2) Flat Floor 3) Quarry

Machine Information and Monitoring

Lowering your cost per ton with vital fleet information



Your G Series truck has the ability to communicate (and receive) valuable information. Information that can lead you to producing at a lower cost per ton.

Instrument Cluster

The instrument cluster is used primarily by the operator for quick and simple machine information at a glance. This display also warns the operator with solid lights (Category 1 Warnings) or flashing lights (Category 2 or 3 Warnings) as well as an audible alarm when an event is occurring.

Cat Advisor Display

The Advisor Display has five menus:

1. **Operator:** allows 10 people to set up individual profiles and preferences.
2. **Monitor:** displays four parameters per screen including
Payload – there are three sections, Payload State; Payload and Target.
Payload State – will display “Loading”; “Last Pass” or “Loaded.”
Payload – displays the calculated payload weight, weight is taken twice to confirm.
Target – displays the target payload.
3. **Service:** diagnostics including events, data logger, parameters, calibrations and more.
4. **Settings:** set specific targets for autolube intervals, speed limit and more.
5. **Service Mode:** a portal to password protected parameters.

VIMS™

Vital Information Management System (VIMS™) is the hardware and software behind the machine information and payload tracking that comes through the Advisor display on your 775G truck. VIMS is standard, and like the Truck Production Management System, can greatly improve your ability to manage your fleet efficiency, machine production and provide operators with vital machine information.

Truck Production Management System (TPMS)

TPMS – Cat Truck Production Management System will help you get the best return on your truck investment by making sure you're hauling appropriate payloads with every cycle.

- Indicator side lights show the loader operator when they are on their last pass and when the truck is fully loaded
- TPMS stores 2,400 payload cycles; reports on weights, haul cycle times, distances, with date and time stamps

Ton Kilometer per Hour (TKPH), Ton Mile per Hour (TMPH) Tire Monitoring

This program takes the payload value from TPMS, combines it with ambient air temperature, machine speed and the manufacturer's TKPH (TMPH) rating for your tires and calculates tire condition continuously. As a tire approaches its temperature limits, the operator gets a warning inside the cab. This Caterpillar exclusive feature is an important tool in your efforts to extend tire life.

NOTE: TKPH (TMPH) is a measure of the tire's temperature limits to prevent reverse vulcanization of the tire and the associated damage.

Cat Product Link

Cat Product Link allows remote monitoring of equipment to improve overall fleet-management effectiveness. Product Link is deeply integrated into machine systems. Events and diagnostic codes, as well as hours, fuel, idle time and other detailed information are transmitted to a secure web based application, VisionLink™. VisionLink includes powerful tools to convey information to users and dealers, including mapping, working and idle time, fuel level and more.

** Product Link licensing not available in all areas. Please consult your Cat dealer for availability.*



Serviceability

Clean, convenient, time-saving solutions



G Series will introduce time-saving service improvements to simplify monitoring and maintaining machine fluid levels, help keep your site clean and reduce your costs associated with service.

Fluid Fill Service Center

A new optional fluid fill service center is located on the right front side of the machine. Technicians can check the level of all machine fluids including:

- Transmission/torque converter hydraulic oil
- Hoist/Brake hydraulic oil
- Diesel fuel
- Engine oil
- Engine coolant



A lighted keypad will indicate three green lights if the fluid level is full, two green lights if the fluid level is at normal levels, and one light if fluid should be added.

Cab Fluid Level Monitoring

The fluid levels cannot be checked in the cab via the Advisor screen options menu. All the fluids are being monitored but will only indicate to the operator when the level is below a safe operating level.

Electrical Service Center

An Electrical Service Center is also at ground level located on the right front bumper of the machine.

This service center offers connections to:

1. Master Disconnect Switch
2. Auxiliary Start Receptacle
3. Light
4. VIMS Port
5. ET Port
6. Hydraulics Lockout
7. Engine Lockout
8. Breaker – Engine Control
9. Breaker – Alternator
10. Breaker – Main Electrical



Brake Wear Indicator

G Series trucks will come equipped from the factory with a simple, time-saving brake wear indicator on the left rear wheel that provides technicians with a visible indicator for rear break wear levels.

Filters

Due to improved hydraulic system updates which have made the system more efficient, Caterpillar is able to extend hydraulic filter life to 1,000 hours under normal operating conditions. All engine filters are conveniently grouped and easily accessible.

Fuel

The 775G fuel tank is now larger (795 L or 210 gallons), to extend running time. The tank includes two new sight gauges that levels at ¼ full and ¾ full. Note that Tier 4 Final equipped machines require ultra-low sulfur diesel fuel and low ash engine oil.

Cab Air Filter Precleaner

An optional cab precleaner is available for air filters. This option can significantly extend your cab filter life and service intervals. Our field follow program machines saw significant benefits to filter life in the G Series machines.

Air Inlet Filters

The engine air inlet filters are conveniently located for secure, simple service.



Safety

Focus on people and resources



Cat trucks offer operators a comfortable, confident ride with safety features that help them stay informed, alert and in control.

Safety

- Ground level daily check points
- Excellent visibility using mirrors, optional camera (WAVS) and in cab display
- Solid, stable walking/working platforms with good traction, material shedding, handrails
- Emergency egress from within the cab through a hinged right-side window
- Ground level electrical service box for lockout/tag out, steering system lockout
- Ground level optional fluid fill center with level check keypad
- Secondary steering, engages automatically
- Three levels of braking (service, secondary, engine) red foot pedal for secondary brakes
- ROPS/FOPS structures in cab
- Brake wear indicator
- Three point harness operator seat belt
- Trainer seat with lap belt
- Body up speed limiting
- Haul road speed limiting, setting safe conditions for everyone
- Automatic Retarder Control, smooth predictable performance
- New Traction Control System, returns the truck to solid footing sooner
- In cab fluid level monitoring for operator
- TKPH/TMPH – Tire Monitoring System
- Truck Production Monitoring System (TPMS) providing payload, fuel, segment and cycle time information
- Engine overspeed protection using ARC
- Three levels of warning for parameters outside of their working zones



Sustainability

Sustainability benefits us all

At Caterpillar, sustainable designs have always been a priority. Cat trucks have historically offered industry leading availability, life cycles and parts commonality. Today we offer even more ways to reduce our impact on the environment.

With G Series, Caterpillar is pleased to be releasing its first North American Tier 4 Final product – two years prior to the implementation of the regulation. In addition to contributing to better air quality, G Series offers lower operator sound levels and new ways to conserve fuel.

- Fuel conservation features: two fuel economy modes, speed limiting, Auto Neutral Idle, Engine Idle Shutdown, new Traction Control System
- Keeping the site clean with grouped service locations, ecology drains and convenient, optional fluid fill and electrical service centers
- Reducing operator cab noise levels by 50% from previous trucks
- Longer component life for tires using TCS and TKPH/TMPH
- Longer life steel spindles, new brake designs, stronger frame
- Cat Reman parts offer recycling and reuse opportunities with no risk
- Longer service life for hydraulic oil filters (1,000 hrs), and air filters with precleaner installed
- Improved air quality with Tier 4 Final emission controls (for North America) reducing No_x and Particulate Matter by 90% over Tier 3 as well as reduced emissions from fuel conservation
- Parts commonality with other Cat equipment

775G Off-Highway Truck Specifications

Engine (Tier 4 Final)

Engine Model	Cat® C27 ACERT™	
Rated Engine Speed	1,800 rpm	
Gross Power – SAE J1995	615 kW	825 hp
Net Power – SAE J1349	572 kW	768 hp
Net Power – ISO 9249	578 kW	775 hp
Net Power – 80/1269/EEC	578 kW	775 hp
Engine Power – ISO 14396	605.2 kW	812 hp
Peak Torque Speed	1,200 rpm	
Net Torque	4269 N·m	3,148 lb-ft
Bore	137 mm	5.4 in
Stroke	152 mm	6 in
Displacement	27 L	1,648 in ³

Engine (Tier 2 Equivalent)

Engine Model	Cat® C27 ACERT™	
Rated Engine Speed	2,000 rpm	
Gross Power – SAE J1995	615 kW	825 hp
Net Power – SAE J1349	584 kW	783 hp
Net Power – ISO 9249	590 kW	791 hp
Net Power – 80/1269/EEC	590 kW	791 hp
Engine Power – ISO 14396	607 kW	813 hp
Peak Torque Speed	1,300 rpm	
Net Torque	3896 N·m	2,874 lb-ft
Bore	137 mm	5.4 in
Stroke	152 mm	6 in
Displacement	27 L	1,648 in ³

- Power rating applies at 2,000 rpm when tested under the specified condition for the specified standard.
- Ratings based on SAE J1995 standard air conditions of 25° C (77° F) and 100 kPa (29.61 Hg) barometer. Power based on fuel having API gravity of 35 at 16° C (60° F) and an LHV of 42 780 kJ/kg (18,390 BTU/lb) when engine used at 30° C (86° F).
- No engine derating required up to 3048 m (10,000 ft) for Tier 4 Final and 3810 m (12,500 ft) for Tier 2 Equivalent.
- Not regulated under EU Stage IV regulations due to power rating above 560 kW (750 hp).

Transmission (Tier 4 Final)

Forward 1	10.6 km/h	6.6 mph
Forward 2	15.0 km/h	9.3 mph
Forward 3	20.3 km/h	12.6 mph
Forward 4	27.0 km/h	16.8 mph
Forward 5	36.7 km/h	22.8 mph
Forward 6	49.4 km/h	30.7 mph
Forward 7	66.9 km/h	41.6 mph
Reverse	14.0 km/h	8.7 mph

Transmission (Tier 2 Equivalent)

Forward 1	10.8 km/h	6.7 mph
Forward 2	15.1 km/h	9.4 mph
Forward 3	20.4 km/h	12.7 mph
Forward 4	27.4 km/h	17.0 mph
Forward 5	37.0 km/h	23.0 mph
Forward 6	50.1 km/h	31.1 mph
Forward 7	67.6 km/h	42.0 mph
Reverse	14.1 km/h	8.8 mph

- Maximum travel speeds with standard 24.00R35 (E4) tires.

Final Drives

Differential Ratio	3.64:1
Planetary Ratio	4.80:1
Total Reduction Ratio	17.49:1

Brakes

Brake Surface – Front	655 cm ²	257 in ²
Brake Surface – Rear	61 269 cm ²	9,497 in ²
Brake Standards	ISO 3450:1996	

Body Hoists (Tier 4 Final)

Pump Flow – High Idle	448 L/min	118 gal/min
Relief Valve Setting – Raise	17 250 kPa	2,502 psi
Relief Valve Setting – Lower	3450 kPa	500 psi
Body Raise Time – High Idle	10.0 seconds	
Body Lower Time – Float	14.0 seconds	
Body Power Down – High Idle	14.0 seconds	

Body Hoists (Tier 2 Equivalent)

Pump Flow – High Idle	448 L/min	118 gal/min
Relief Valve Setting – Raise	17 250 kPa	2,502 psi
Relief Valve Setting – Lower	3450 kPa	500 psi
Body Raise Time – High Idle	9.5 seconds	
Body Lower Time – Float	13.0 seconds	
Body Power Down – High Idle	13.0 seconds	

Capacity – Dual Slope – 100% Fill Factor

Struck	32.6 m ³	42.7 yd ³
Heaped 2:1 (SAE)	42.2 m ³	55.5 yd ³

Capacity – Flat Floor – 100% Fill Factor

Struck	32.3 m ³	42.2 yd ³
Heaped 2:1 (SAE)	42.2 m ³	55.2 yd ³

Weight Distributions – Approximate

Front Axle – Empty	50%
Front Axle – Loaded	34%
Rear Axle – Empty	50%
Rear Axle – Loaded	66%

Suspension

Empty Loaded Cylinder Stroke Front	234 mm	9.2 in
Empty Loaded Cylinder Stroke Rear	149 mm	5.8 in
Rear Axle Oscillation	8.1°	

Sound

Sound Standards

- The operator Equivalent Sound Pressure Level (Leq) is 76 dB(A) when SAE J1166 FEB2008 is used to measure the value for an enclosed cab. This is a work cycle sound exposure level. The cab was properly installed and maintained. The test was conducted with the cab doors and the cab windows closed.
- The exterior sound pressure level for the standard machine measured at a distance of 15 m (49 ft) according to the test procedures specified in SAE J88:2008, mid-gear moving operation is 86 dB(A).
- Hearing protection may be needed when operating with an open operator station and cab (when not properly maintained or doors/windows open) for extended periods or in a noisy environment.

Service Refill Capacities

Fuel Tank	795 L	210 gal
Cooling System	171 L	45 gal
Crankcase	90 L	24 gal
Differentials and Final Drives	145 L	38 gal
Steering Tank	36 L	9.5 gal
Steering System (includes tank)	54 L	14 gal
Brake/Hoist Hydraulic Tank	176 L	46.5 gal
Brake Hoist System	322 L	85 gal
Torque Converter/ Transmission System HRC	70 L	18 gal
Torque Converter/ Transmission System LRC	61 L	16 gal

Steering

Steering Standards	SAE J1511 FEB94 ISO 5010:1992	
Steer Angle	31°	
Turning Diameter – Front	23.5 m	77 ft 1 in
Turning Circle Clearance Diameter	26.1 m	85 ft 8 in

Tires

Standard Tire 24.00R35 (E4)

- Productive capabilities of the 775G truck are such that, under certain job conditions, TKPH (TMPH) capabilities of standard or optional tires could be exceeded and, therefore, limit production.
- Caterpillar recommends the customer evaluate all job conditions and consult the tire manufacturer for proper tire selection.

ROPS

ROPS/FOPS Standards

- ROPS (Rollover Protective Structure) for cab offered by Caterpillar meets ISO 3471:2008 ROPS criteria.
- FOPS (Falling Objects Protective Structure) meets ISO 3449:2005 Level II FOPS criteria.

775G Off-Highway Truck Specifications

Weight/Payload Calculation (Tier 4 Final Example)

775G – Flat Floor		354-7900 Base Body	377-6400 Base Body/Liner	354-7950 Quarry Body	377-6402 Rubber Liner
Floor/Sidewall/Frontwall	mm (in)	20/10/12 (0.79/0.39/0.47)	36/18/22 (1.42/0.71/0.87)	25/14/16 (0.98/0.55/0.63)	102/8/8 + 20/10/12 (4.0/0.31/0.31) + (0.79/0.39/0.47)
Payload Capacity	m ³ (yd ³)	42.2 (55.2)	41.6 (54.4)	41.9 (54.9)	39.8 (52.0)
	mm (in)	20 (0.787)	20 (0.787)	25 (1.0)	102 (4.0)
Target Gross Machine Weight	kg (lb)	111 811 (246,500)	111 811 (246,500)	111 811 (246,500)	111 811 (246,500)
Empty Chassis Weight	kg (lb)	35 708 (78,723)	35 708 (78,723)	35 708 (78,723)	35 708 (78,723)
Body System Weight	kg (lb)	11 760 (25,926)	15 885 (35,020)	13 827 (30,483)	16 732 (36,887)
Empty Machine Weight	kg (lb)	47 468 (104,649)	51 593 (113,743)	49 535 (109,206)	52 440 (115,610)
Attachments					
Fuel Tank Size	L (gal)	795 (210)	795 (210)	795 (210)	795 (210)
Fuel Tank – 100% Fill	kg (lb)	669 (1,474)	669 (1,474)	669 (1,474)	669 (1,474)
Empty Operating Weight**	kg (lb)	48 137 (106,123)	52 262 (115,217)	50 204 (110,680)	53 108 (117,084)
Target Payload*	kg (lb)	63 674 (140,377)	59 549 (131,283)	61 607 (135,820)	58 702 (129,416)
Target Payload*	tonnes (tons)	63.7 (70.2)	59.5 (65.6)	61.6 (67.9)	58.7 (64.7)
10/10/20 Policy*					
Nominal Payload – 100%	kg (lb)	63 674 (140,377)	59 549 (131,283)	61 607 (135,820)	58 702 (129,416)
Maximum Working Payload – 110%	kg (lb)	70 041 (154,414)	65 504 (144,411)	67 768 (149,401)	64 572 (142,357)
Not to Exceed Payload – 120%	kg (lb)	76 409 (168,452)	71 459 (157,539)	73 928 (162,983)	70 443 (155,299)
Maximum Gross Machine Weight*	kg (lb)	124 545 (274,575)	123 720 (272,757)	124 132 (273,664)	123 551 (272,383)
775G – Dual Slope					
		354-7910 Base Body	377-6410 Base Body/Liner	No Quarry Body Offered	No Rubber Liner Offered
Floor/Sidewall/Frontwall	mm (in)	20/10/12 (0.79/0.39/0.47)	36/18/22 (1.42/0.71/0.87)		
Payload Capacity	m ³ (yd ³)	42.2 (55.2)	41.7 (54.5)		
	mm (in)	20 (0.787)	25 (1.0)		
Target Gross Machine Weight	kg (lb)	111 811 (246,500)	111 811 (246,500)		
Empty Chassis Weight	kg (lb)	35 708 (78,723)	35 708 (78,723)		
Body System Weight	kg (lb)	11 466 (25,278)	15 482 (34,132)		
Empty Machine Weight	kg (lb)	47 174 (104,001)	51 190 (112,855)		
Attachments					
Fuel Tank Size	L (gal)	795 (210)	795 (210)		
Fuel Tank – 100% Fill	kg (lb)	669 (1,474)	669 (1,474)		
Empty Operating Weight**	kg (lb)	47 843 (105,475)	51 859 (114,329)		
Target Payload*	kg (lb)	63 968 (141,025)	59 952 (132,171)		
Target Payload*	tonnes (tons)	64.0 (70.5)	60.0 (66.1)		
10/10/20 Policy*					
Nominal Payload – 100%	kg (lb)	63 968 (141,025)	59 952 (132,171)		
Maximum Working Payload – 110%	kg (lb)	70 365 (155,127)	65 947 (145,388)		
Not to Exceed Payload – 120%	kg (lb)	76 761 (169,229)	71 942 (158,605)		
Maximum Gross Machine Weight*	kg (lb)	124 604 (274,705)	123 801 (272,934)		

*Refer to Caterpillar 10/10/20 overload policy.

**Includes weight of all attachments.

10/10/20 Payload Management Policy for Optimal Machine Life

The ideal hauling strategy that maximizes machine and machine component life is to *keep the mean of all payloads at or below the machine's rated target payload.*

- 90% of loads should fall into this range
- No more than 10% of loads should exceed 10% of the target payload
- No loads should be above 20% of the target payload

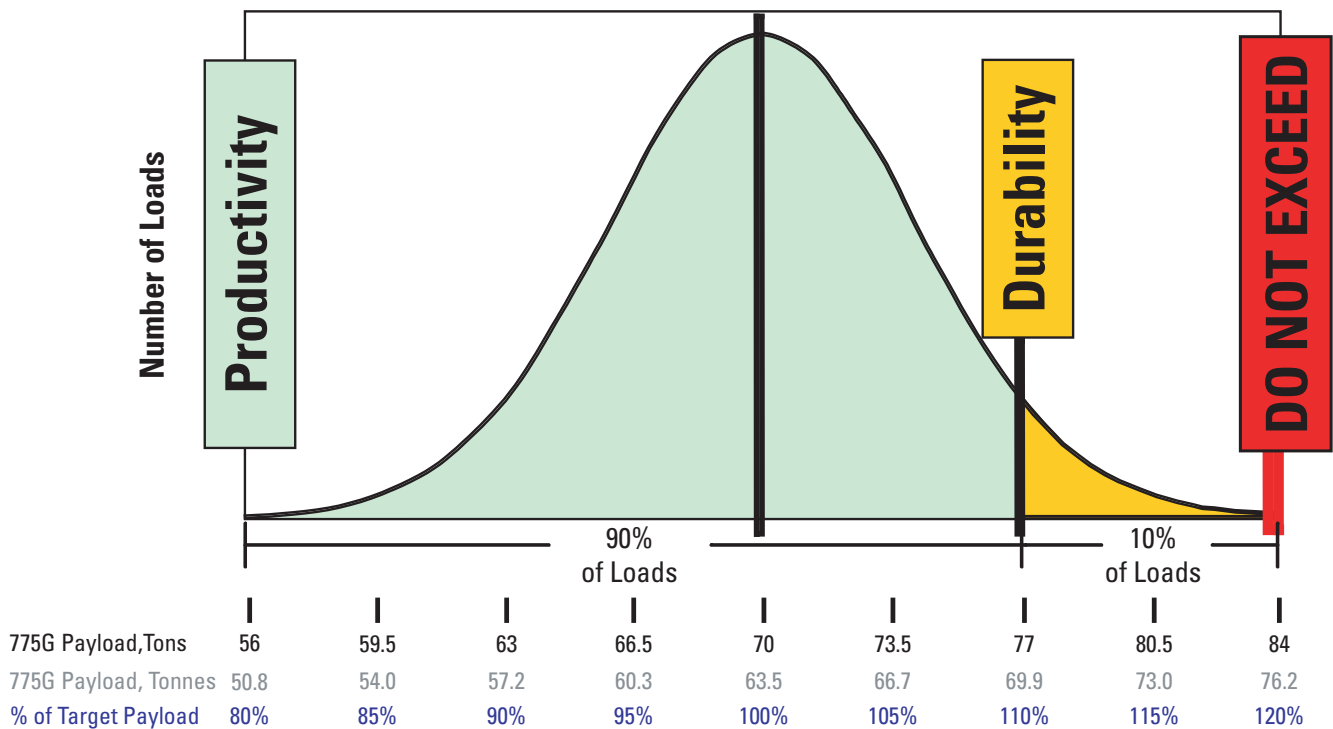

775G Off-Highway Truck Specifications

Dimensions

All dimensions are approximate.

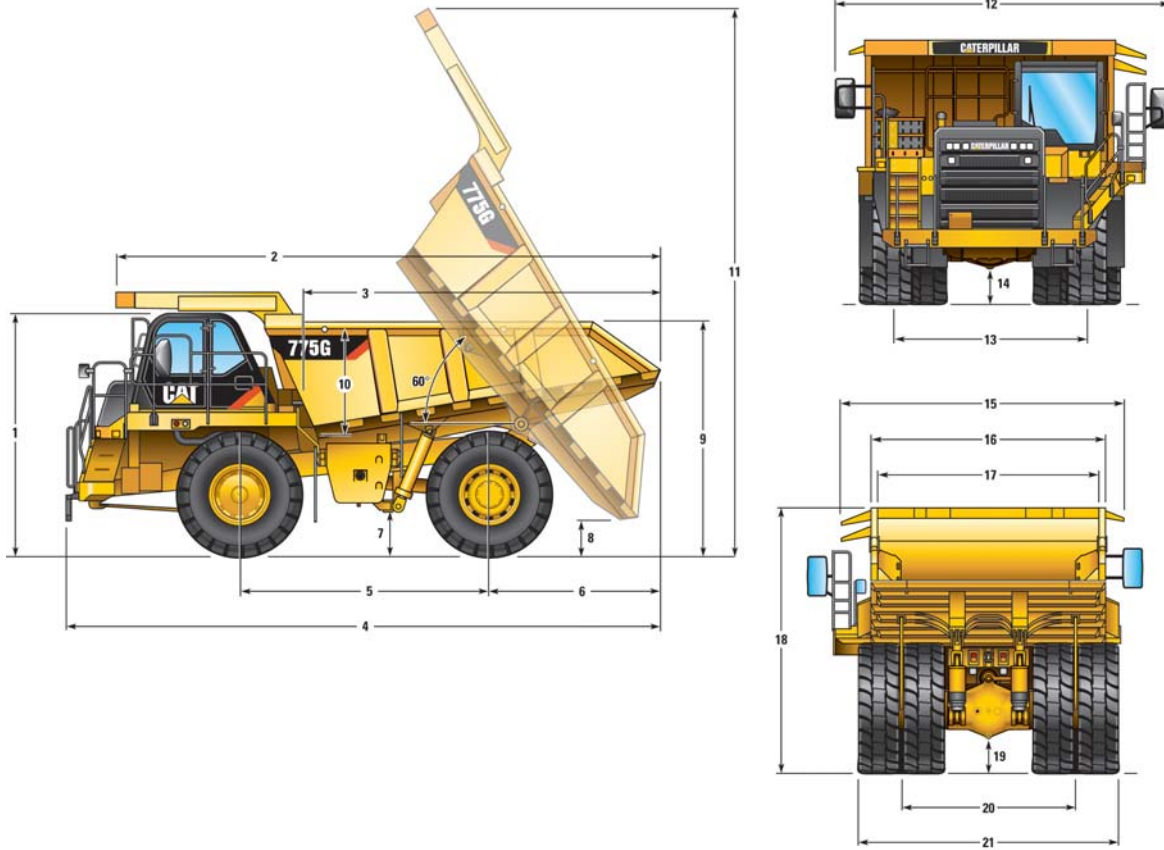

	Dual Slope		Flat Floor		Quarry	
1 Height to Top of ROPS	4108 mm	13.48 ft	4108 mm	13.48 ft	4108 mm	13.48 ft
2 Overall Body Length	9215 mm	30.23 ft	9293 mm	30.49 ft	9295 mm	30.50 ft
3 Inside Body Length	6100 mm	20.01 ft	6100 mm	20.01 ft	6100 mm	20.01 ft
4 Overall Length	10 073 mm	33.05 ft	10 151 mm	33.30 ft	10 151 mm	33.30 ft
5 Wheelbase	4215 mm	13.83 ft	4215 mm	13.83 ft	4215 mm	13.83 ft
6 Rear Axle to Tail	2925 mm	9.60 ft	3005 mm	9.86 ft	3005 mm	9.86 ft
7 Ground Clearance	759 mm	2.49 ft	759 mm	2.49 ft	759 mm	2.49 ft
8 Dump Clearance	650 mm	2.13 ft	639 mm	2.10 ft	639 mm	2.10 ft
9 Loading Height – Empty	3963 mm	13.00 ft	3964 mm	13.01 ft	3968 mm	13.02 ft
10 Inside Body Depth – Maximum	1945 mm	6.38 ft	1892 mm	6.21 ft	1892 mm	6.21 ft
11 Overall Height – Body Raised	9279 mm	30.44 ft	9279 mm	30.44 ft	9283 mm	30.46 ft
12 Operating Width	5673 mm	18.61 ft	5673 mm	18.61 ft	5673 mm	18.61 ft
13 Centerline Front Tire Width	3205 mm	10.52 ft	3205 mm	10.52 ft	3205 mm	10.52 ft
14 Engine Guard Clearance	703 mm	2.31 ft	703 mm	2.31 ft	703 mm	2.31 ft
15 Overall Canopy Width	5012 mm	16.44 ft	5012 mm	16.44 ft	5012 mm	16.44 ft
16 Outside Body Width	4254 mm	13.96 ft	4254 mm	13.96 ft	4254 mm	13.96 ft
17 Inside Body Width	3986 mm	13.08 ft	3986 mm	13.08 ft	3986 mm	13.08 ft
18 Front Canopy Height	4459 mm	14.63 ft	4457 mm	14.62 ft	4463 mm	14.64 ft
19 Rear Axle Clearance	560 mm	1.84 ft	560 mm	1.84 ft	560 mm	1.84 ft
20 Centerline Rear Dual Tire Width	2929 mm	9.61 ft	2929 mm	9.61 ft	2929 mm	9.61 ft
21 Overall Tire Width	4411 mm	14.47 ft	4411 mm	14.47 ft	4411 mm	14.47 ft

Retarding Performance (Tier 4 Final)

To determine retarding performance: Add lengths of all downhill segments and, using this total, refer to proper retarding chart. Read from gross weight down to the percent effective grade. Effective grade equals actual % grade minus 1% for each 10 kg/t (20 lb/ton) of rolling resistance. From this weight-effective grade point, read horizontally to the curve with the highest obtainable gear, then down to maximum descent speed brakes can properly handle without exceeding cooling capacity. The following charts are based on these conditions: 32° C (90° F) ambient temperature, at sea level, with 24.00R35 (E4) tires.

NOTE: Select the proper gear to maintain engine rpm at the highest possible level, without overspeeding the engine.
If cooling oil overheats, reduce ground speed to allow transmission to shift to the next lower speed range.

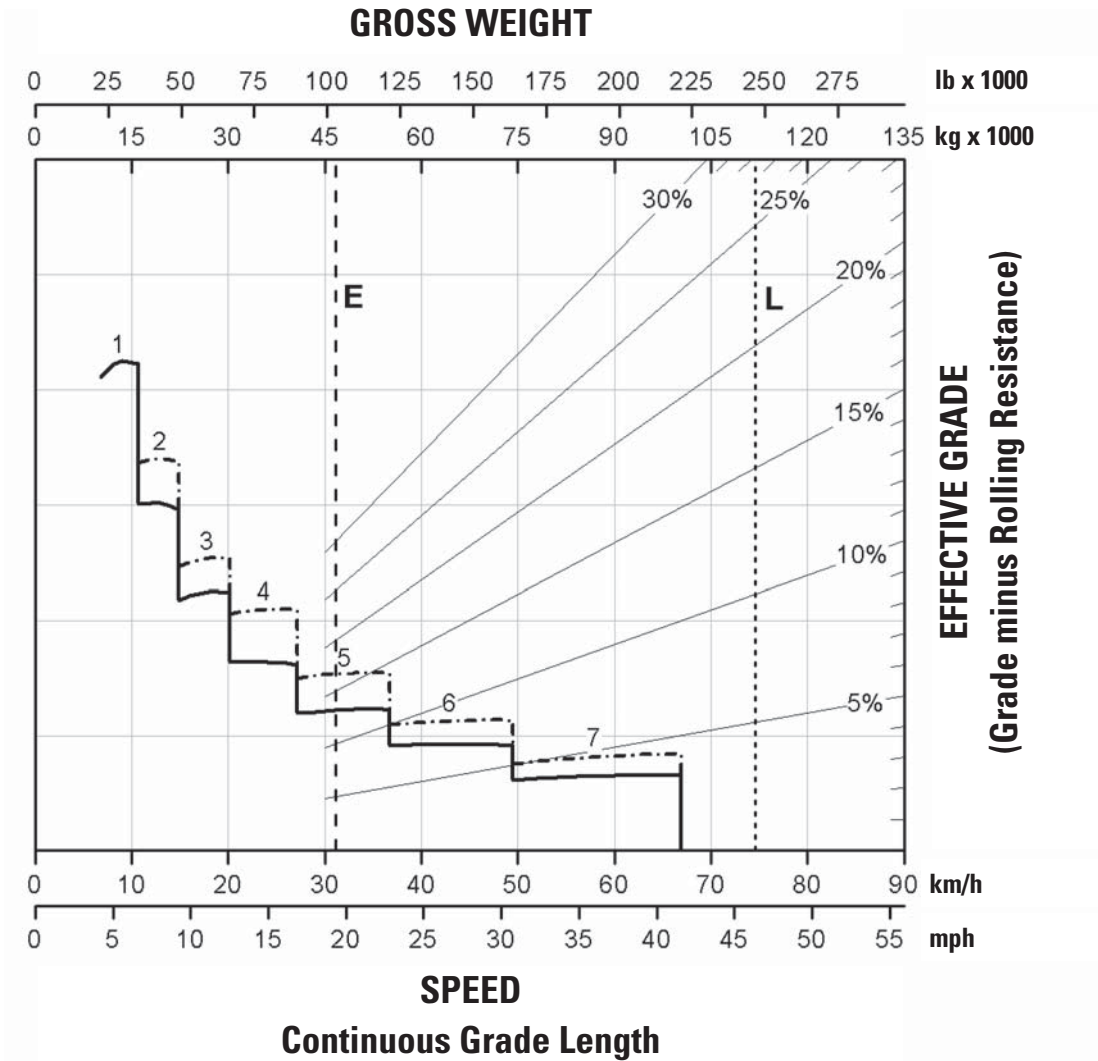

———— with ARC only

- - - - - ARC and Engine Brake

E – Typical Field Empty Weight

L – Target Gross Machine Operating Weight 111 811 kg (246,500 lb)

775G Off-Highway Truck Specifications

Retarding Performance (Tier 4 Final)

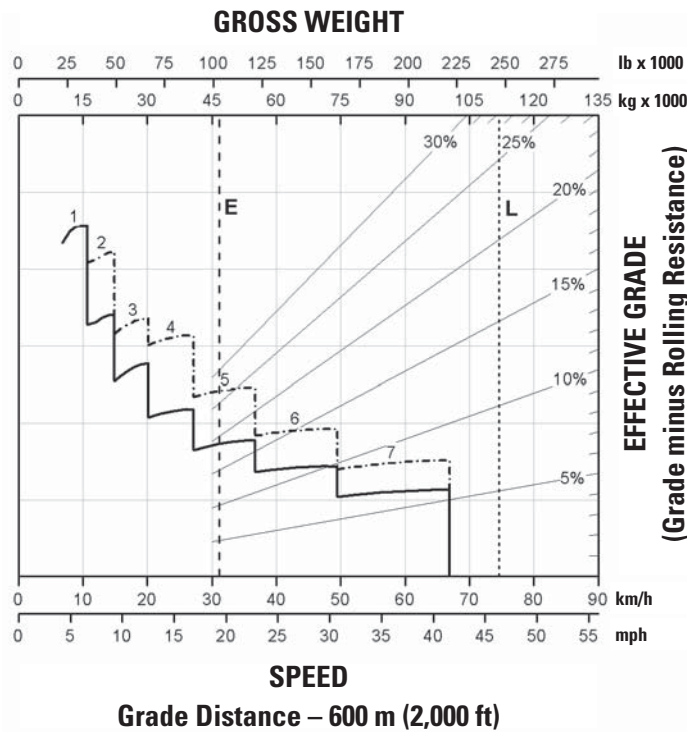
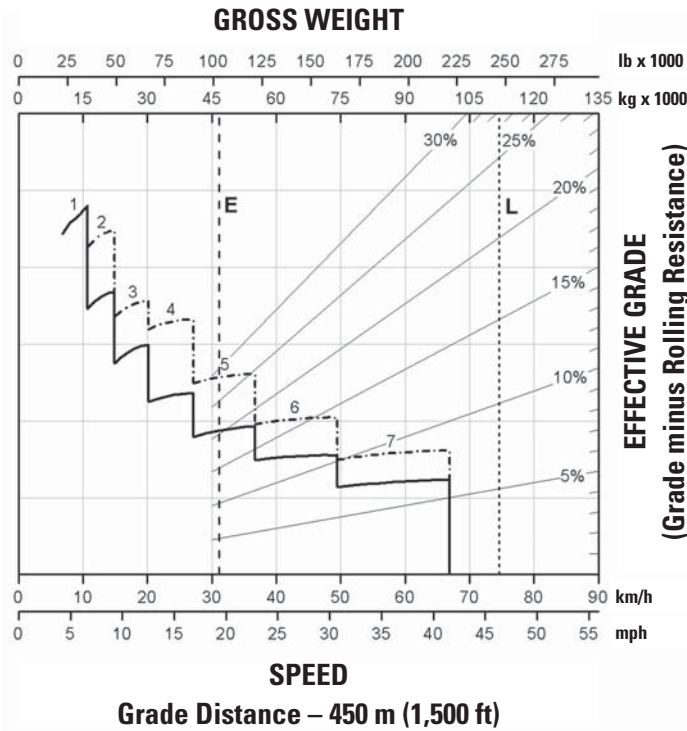

- with ARC only
- - - - - ARC and Engine Brake
- E – Typical Field Empty Weight
- L – Target Gross Machine Operating Weight 111 811 kg (246,500 lb)

Retarding Performance (Tier 4 Final)

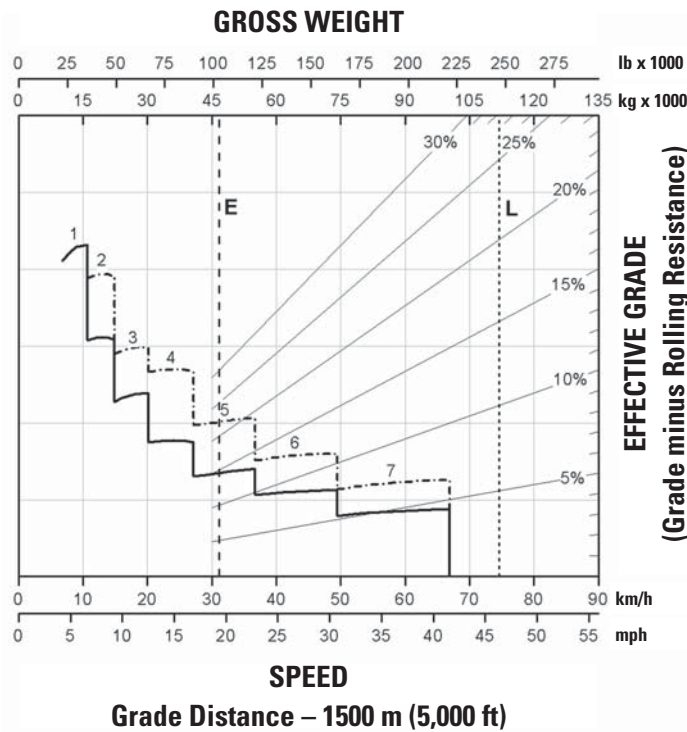
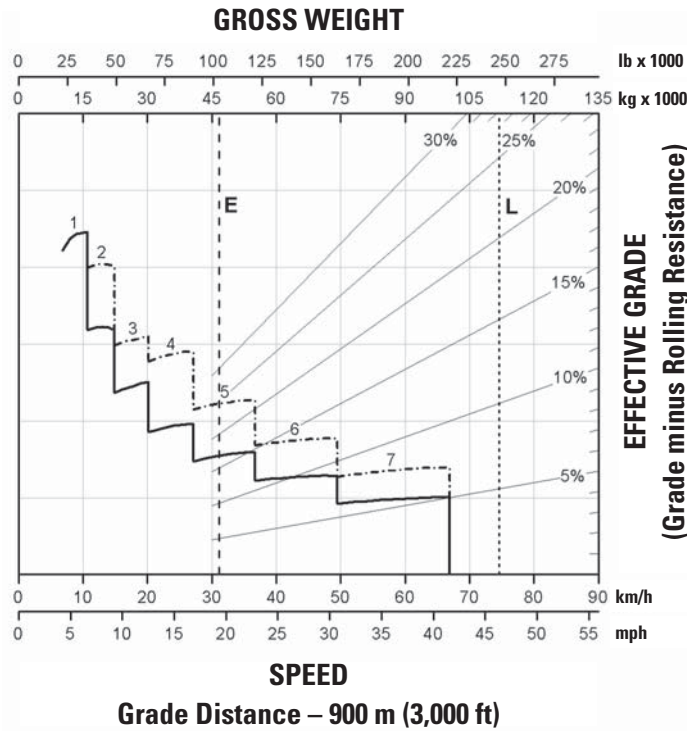

- with ARC only
- - - - - ARC and Engine Brake
- E – Typical Field Empty Weight
- L – Target Gross Machine Operating Weight 111 811 kg (246,500 lb)

775G Off-Highway Truck Specifications

Gradeability/Speed/Rimpull (Tier 4 Final)

To determine gradeability performance: Read from gross weight down to the percent of total resistance. Total resistance equals actual percent grade plus 1% for each 10 kg/t (20 lb/ton) of rolling resistance. From this weight-resistance point, read horizontally to the curve with the highest obtainable gear, then down to maximum speed. Usable rimpull will depend upon traction available and weight on drive wheels.

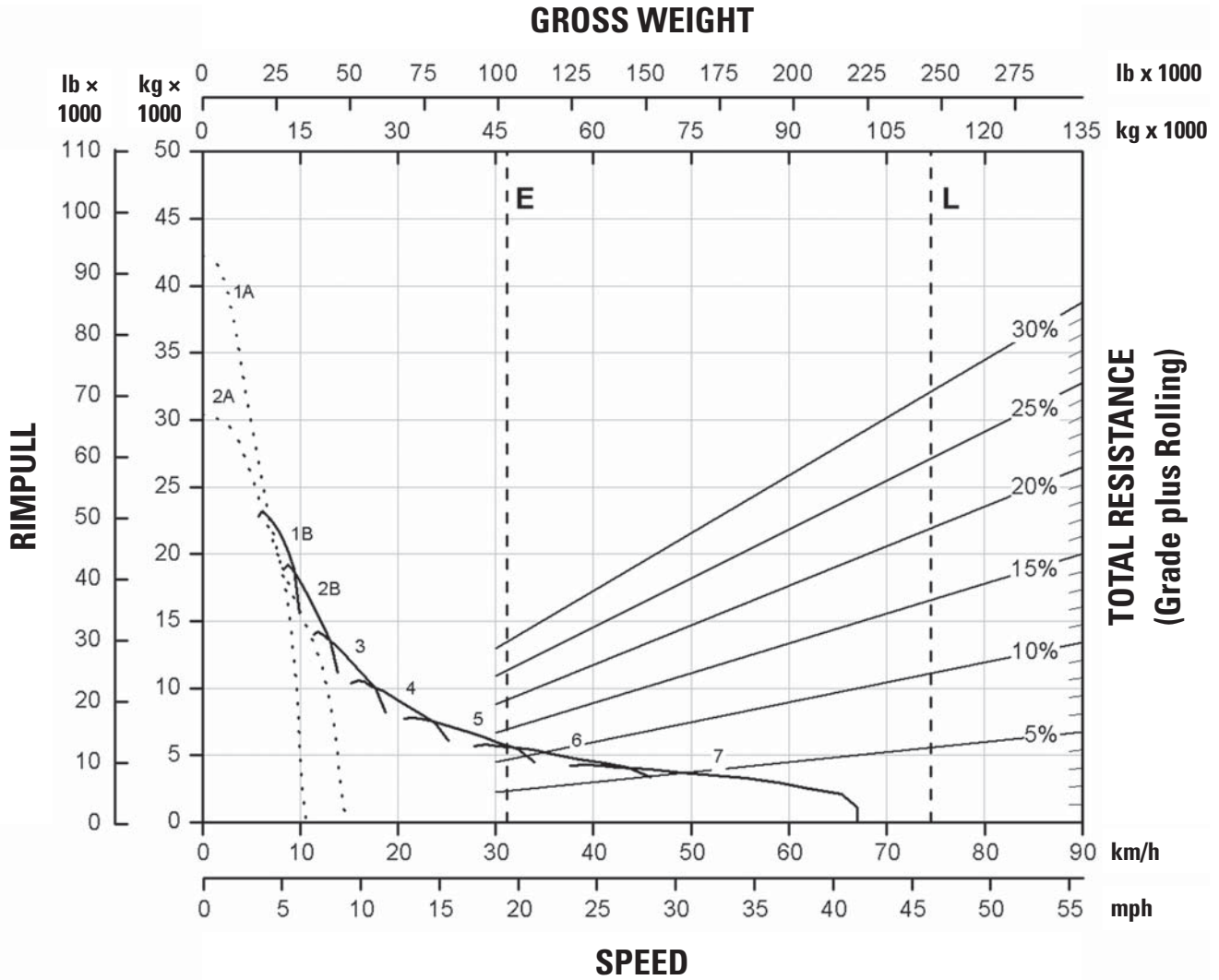

- with ARC only
- ARC and Engine Brake
- E – Typical Field Empty Weight
- L – Target Gross Machine Operating Weight 111 811 kg (246,500 lb)

Retarding Performance (Tier 2 Equivalent)

To determine retarding performance: Add lengths of all downhill segments and, using this total, refer to proper retarding chart. Read from gross weight down to the percent effective grade. Effective grade equals actual % grade minus 1% for each 10 kg/t (20 lb/ton) of rolling resistance. From this weight-effective grade point, read horizontally to the curve with the highest obtainable gear, then down to maximum descent speed brakes can properly handle without exceeding cooling capacity. The following charts are based on these conditions: 32° C (90° F) ambient temperature, at sea level, with 24.00R35 (E4) tires.

NOTE: Select the proper gear to maintain engine rpm at the highest possible level, without overspeeding the engine.
If cooling oil overheats, reduce ground speed to allow transmission to shift to the next lower speed range.

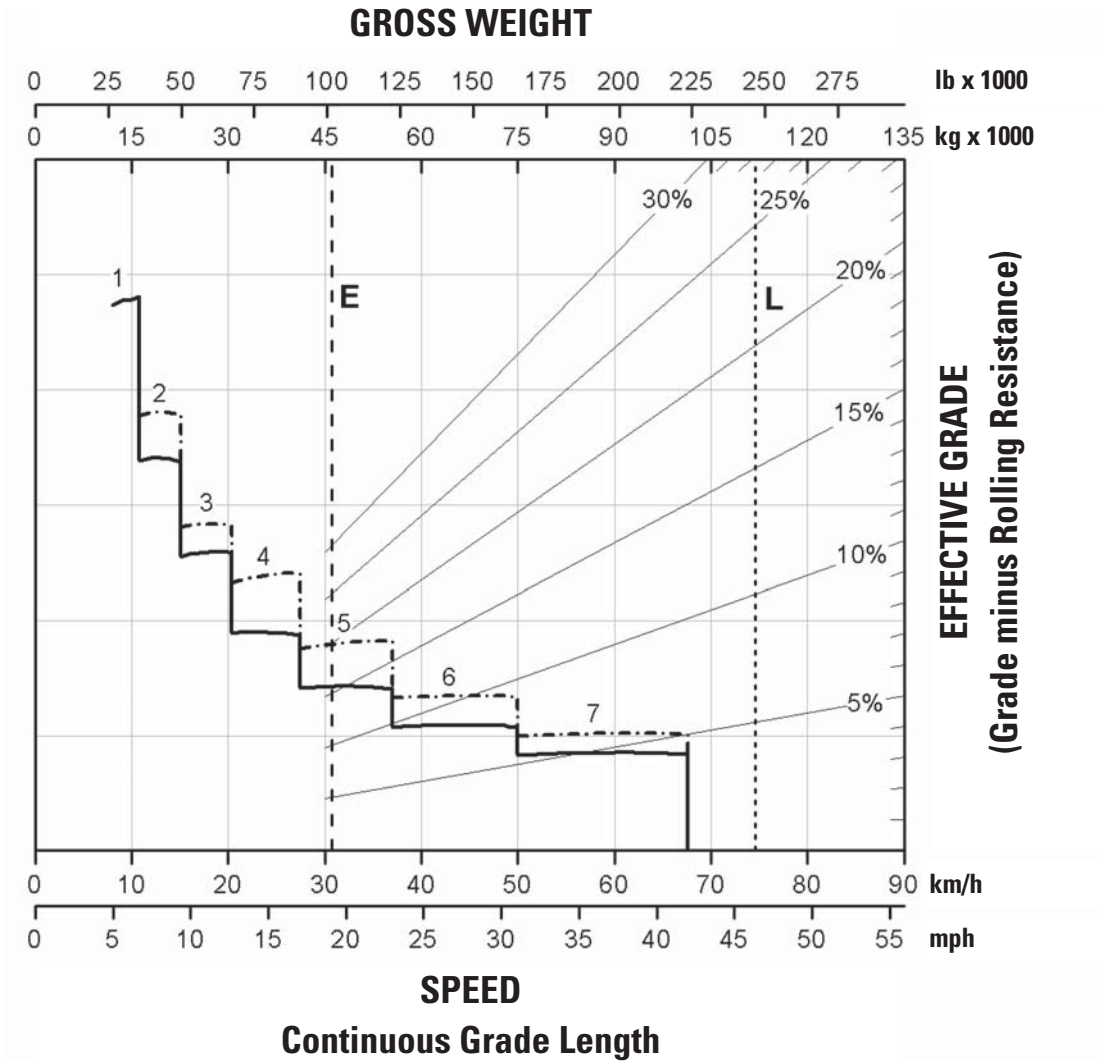

———— with ARC only

- - - - - ARC and Engine Brake

E – Typical Field Empty Weight

L – Target Gross Machine Operating Weight 111 811 kg (246,500 lb)

775G Off-Highway Truck Specifications

Retarding Performance (Tier 2 Equivalent)

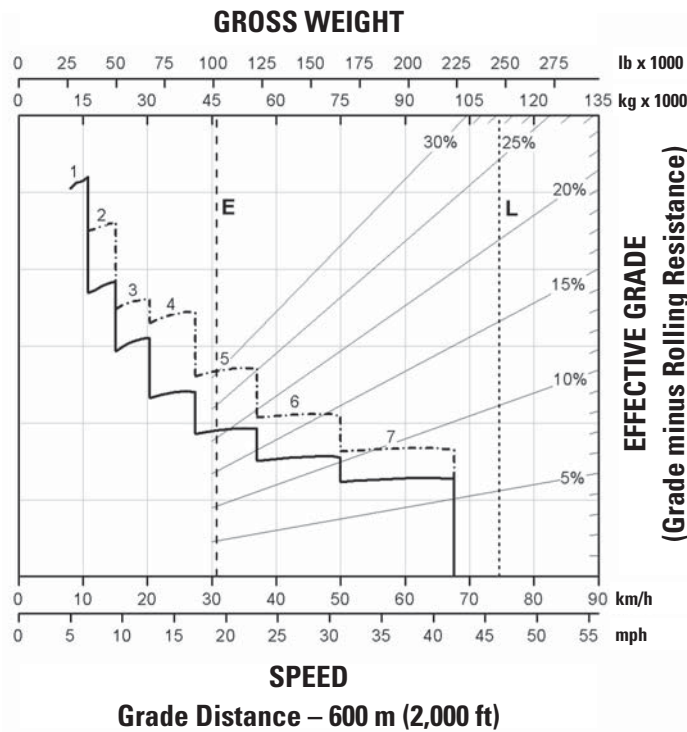
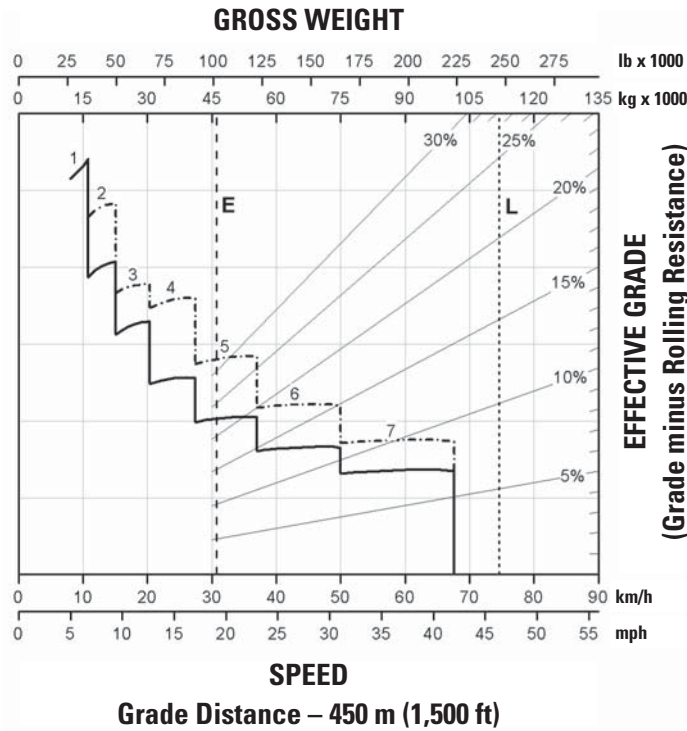

- with ARC only
- - - - - ARC and Engine Brake
- E – Typical Field Empty Weight
- L – Target Gross Machine Operating Weight 111 811 kg (246,500 lb)

Retarding Performance (Tier 2 Equivalent)

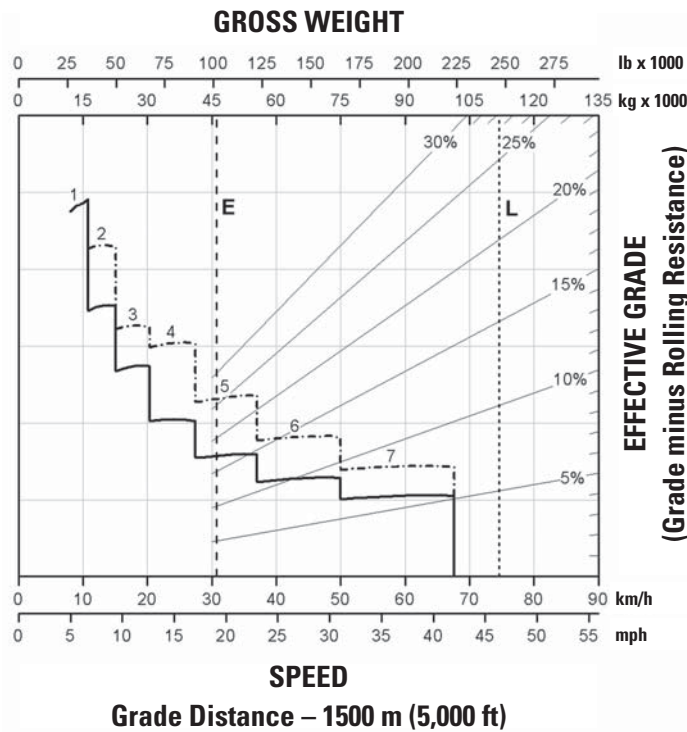
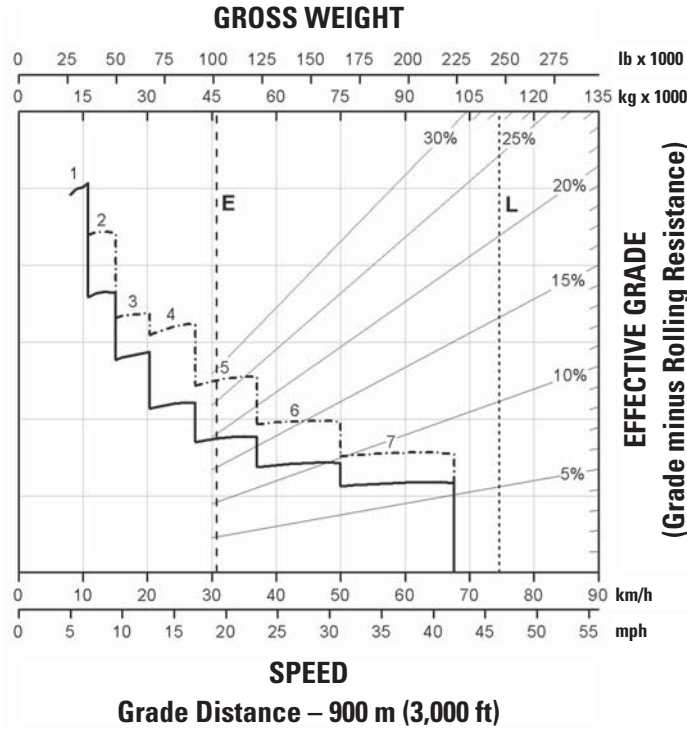

- with ARC only
- - - - - ARC and Engine Brake
- E – Typical Field Empty Weight
- L – Target Gross Machine Operating Weight 111 811 kg (246,500 lb)

775G Off-Highway Truck Specifications

Gradeability/Speed/Rimpull (Tier 2 Equivalent)

To determine gradeability performance: Read from gross weight down to the percent of total resistance. Total resistance equals actual percent grade plus 1% for each 10 kg/t (20 lb/ton) of rolling resistance. From this weight-resistance point, read horizontally to the curve with the highest obtainable gear, then down to maximum speed. Usable rimpull will depend upon traction available and weight on drive wheels.

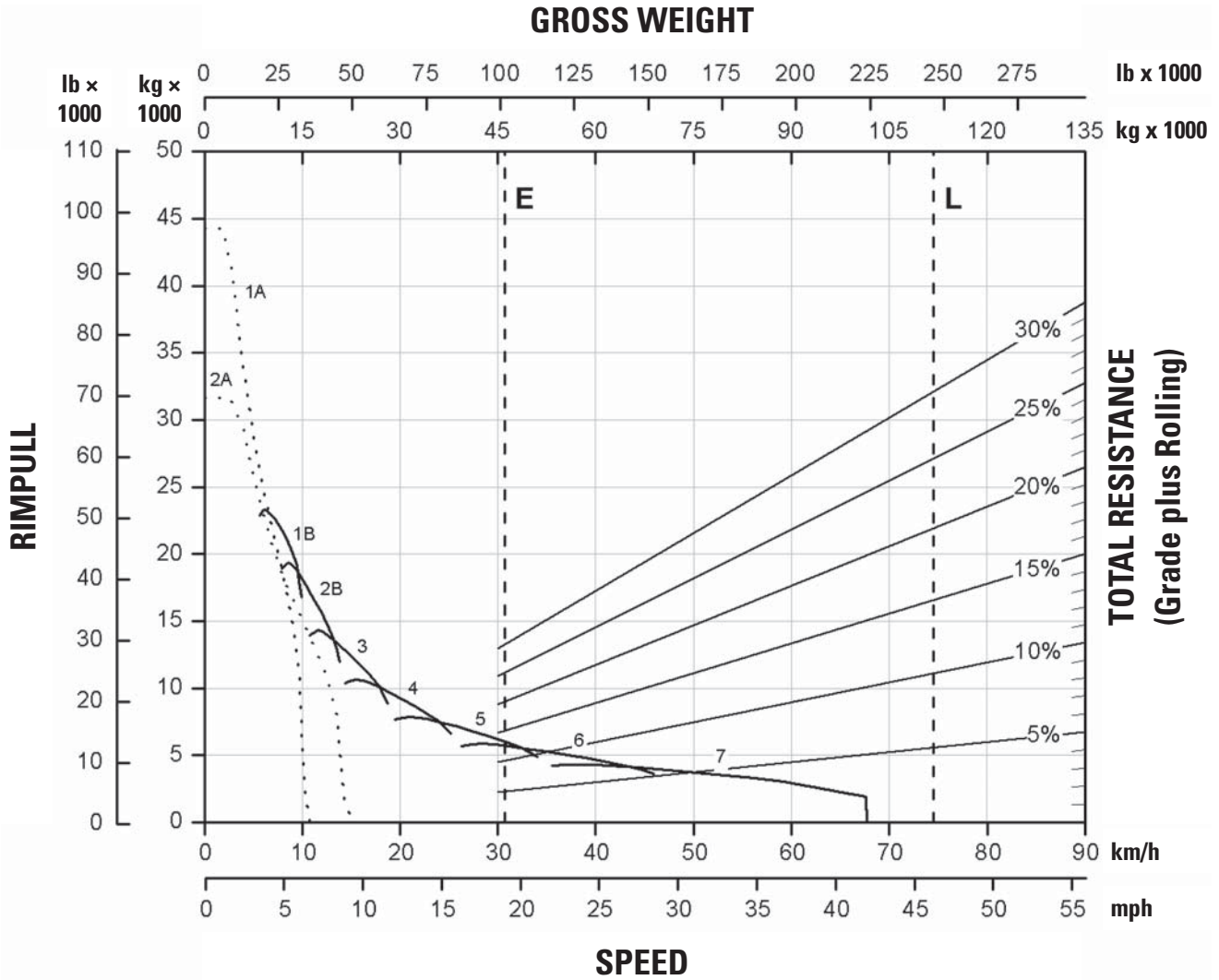

- with ARC only
- ARC and Engine Brake
- E – Typical Field Empty Weight
- L – Target Gross Machine Operating Weight 111 811 kg (246,500 lb)

Standard equipment may vary. Consult your Cat dealer for details.

POWER TRAIN

Cat C27 ACERT Tier 4 Final compliant diesel engine:

- Air cleaner with precleaner (2)
- Air-To-Air Aftercooler (ATAAC)
- Electric start
- Engine idle shutdown
- Ether starting aid
- Exhaust muffler
- NGMR radiator

For Tier 4 regions only (U.S./Canada):

- Aftertreatment system
 - NO_x Reduction System (NRS)
 - Diesel Oxidation Catalyst (DOC)
- Demand fan
- MEUI-C fuel system

For non-regulated regions only:

- Direct drive fan
- MEUI-A fuel system

Braking system:

- Automatic Retarder Control (ARC)
- Manual retarder (utilizes rear oil cooled, multiple disc brakes)
- Brake release motor (towing)
- Dry disc brakes (front)
- Front brake disconnect switch (front)
- Oil-cooled multiple disc brakes (rear)
- Brake wear indicator (rear)
- Parking brake
- Secondary brake
- Service brake

Transmission:

- 7 speed automatic powershift with
 - Electronic Clutch Pressure Control (ECPC)
 - Advanced Productivity Electronic Control Strategy (APECS)
- Automatic neutral idle
- Autostall
- Second gear start

SUSPENSION SYSTEMS

Suspension, front and rear (EU compliant)

ELECTRICAL

- Alarm backup
- Alternator, 120 Amp
- Autolube power supply ready
- Batteries, maintenance-free, 12V (2), 1,400 CCA combined
- Electrical system, 25 Amp, 24V to 12V converter
- Lighting system:
 - Backup light (halogen)
 - Directional signals/hazard warning (front and rear LED)
 - Engine compartment light
 - Headlights, (halogen) with dimmer
 - Operator access courtesy lights
 - Side profile lights
 - Stop/tail lights (LED)
- Service center containing:
 - Battery jump start
 - Breakers with spare fuses
 - Lock out switch
 - Ports, ET and VIMS
 - Service lockout switch (power without engine start)

TECHNOLOGY PRODUCTS

- Economy Modes, standard and adaptive
- Product Link, cellular or satellite
- Traction Control System (TCS)
- Truck Production Management System (TPMS)
- Vital Information Management System (VIMS)

OPERATOR ENVIRONMENT

Advisor display:

- Air cleaner service indicator
- Fluid level monitoring
- Fuel level monitoring
- Display languages (market based)

Air conditioning/heat

Automatic temperature control

Ashtray and cigarette lighter

Coat hook

Cup holders (4)

Diagnostic connection port, 24V

Entertainment radio ready:

- 5 amp converter
- Speakers
- Antenna
- Wiring harness

Foot rest

Gauges/indicators:

- Brake oil temperature gauge
- Coolant temperature gauge
- Engine overspeed indicator
- Fuel level
- Hour meter
- Speedometer with odometer
- Tachometer
- Transmission gear indicator

Hoist lever

Horn

Light – courtesy

Light – dome

Mirrors, non-heated

Power port, 24V and 12V (2)

Rollover Protection (ROPS)/

Falling Object Protection (FOPS)

Seat, Cat Comfort Series III:

- Full air suspension
- Retractable 3-point seat belt with shoulder harness

Seat, training with lap belt

Steering wheel, padded, tilt and telescopic

Storage compartment

Sun visor

Throttle lock

Window, hinged, right side (emergency exit)

Window, powered, left side

Windshield wiper intermittent and washer

775G Standard Equipment

Standard equipment (cont'd)

GUARDS

Driveline
Engine crankcase
Fan

FLUIDS

Antifreeze
Extended life coolant to -34°C (-30°F)
Grouped ground-level filters

OTHER STANDARD EQUIPMENT

Body down indicator
Body safety pin (secures body in up position)
Center mounted rims
Fuel tank, 795 L (210 gal)
Ground level battery disconnect
Ground level engine shutdown
Ground level grease fittings
Operator Maintenance Manual (OMM)
Rims 17 × 35
Rock ejectors
Secondary steering (electric)
Tie down eyes
Tow hooks (front)/tow pin (rear)
Vandalism protection locks

Optional equipment may vary. Consult your Cat dealer for details.

Body heat

Body liner

Body side boards

Cab precleaner

Cat Engine Brake

Clustered grease fittings

Cold weather packages

Extended Life Brakes

Fluid fill service center

HID lights

Mirrors, convex

Mirrors, heated

Spare rim

Visibility package

(meets ISO 5006 requirements)

Wheel chocks

Work Area Vision System (WAVS)

775G Off-Highway Truck

For more complete information on Cat products, dealer services, and industry solutions, visit us on the web at www.cat.com

© 2012 Caterpillar Inc.
All rights reserved

Materials and specifications are subject to change without notice. Featured machines in photos may include additional equipment. See your Cat dealer for available options.

CAT, CATERPILLAR, SAFETY.CAT.COM, their respective logos, "Caterpillar Yellow" and the "Power Edge" trade dress, as well as corporate and product identity used herein, are trademarks of Caterpillar and may not be used without permission.

AEHQ6350-02 (02-2012)
Replaces AEHQ6350-01

