

777G

Off-Highway Truck



Engine (Tier 4 Final)

Engine Model	Cat® C32 ACERT™	
Gross Power – SAE J1995	765 kW	1,025 hp
Net Power – SAE J1349	683 kW	916 hp

Engine (Tier 2 Equivalent)

Engine Model	Cat® C32 ACERT™	
Gross Power – SAE J1995	765 kW	1,025 hp
Net Power – SAE J1349	704 kW	945 hp

Weights – Approximate (Tier 4 Final)

Target Gross Machine Weight	164 654 kg	363,000 lb
-----------------------------	------------	------------

Weights – Approximate (Tier 2 Equivalent)

Target Gross Machine Weight	164 654 kg	363,000 lb
-----------------------------	------------	------------

Operating Specifications (Tier 4 Final)

Nominal Payload (100%)	89.4 tonnes	98.4 tons
Maximum Payload (110%)	98.3 tonnes	108.2 tons
Not to Exceed Payload (120%)*	107.2 tonnes	118.1 tons
Body Capacity – SAE 2:1	64.1 m ³	83.8 yd ³

Operating Specifications (Tier 2 Equivalent)

Nominal Payload (100%)	90.8 tonnes	100 tons
Maximum Payload (110%)	99.8 tonnes	110 tons
Not to Exceed Payload (120%)	109 tonnes	120 tons
Body Capacity – SAE 2:1	64.1 m ³	83.8 yd ³

• Capacity with flat floor X Body with liner.

* Refer to the Caterpillar 10/10/20 Payload Policy for maximum gross vehicle weight limitations.

G Series – a commitment to your safety, people, and business



Contents

Safety	4
Operator Work Environment	6
Environmental Responsibility.....	8
Cutting Your Fuel Costs	10
Performance	11
Long Term Value and Durability.....	12
Body Options.....	14
XQ Package.....	16
Mud Protection Package.....	16
Service Convenience	17
Specifications.....	18
Standard Equipment.....	34
Optional Equipment.....	35



G Series represents a new era for this size class from Caterpillar. With your input, we have designed and manufactured a truck that is reliable, economical and offers comfort, confidence and control for your operators. Your long-term success is our goal; with G Series trucks, we're on the right road.

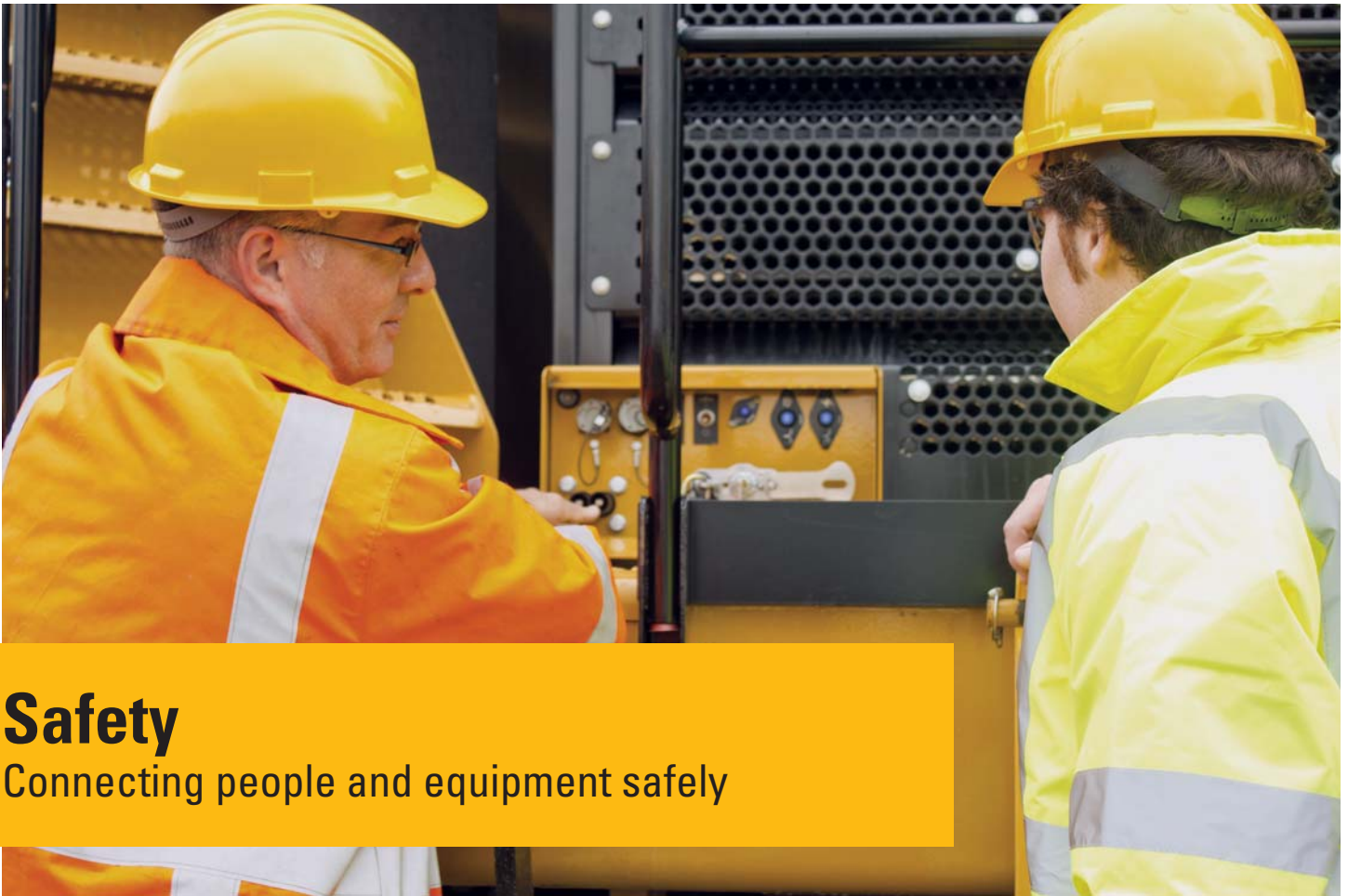

Safety

Connecting people and equipment safely

A Focus on Personnel

The 777G is designed to minimize slips and falls, providing firm footing and stability.

- Ground level daily check points
- Low effort, integrated access system with hand rails for three points of contact
- Aggressive tread plate on all step areas with lighted access for after dark
- Integrated windshield washing platform

Confidence and Control

Confident operators will move material quickly, efficiently and profitably.

- Wet Disc Braking is standard on all four corners of the truck
- Four corner park brake for slope holding capability and brake wear indicator
- Automatic Retarding Control for downhill grades
- New traction control system

Visibility

The 777G supports your site safety plan with object detection.

- Visual or audible warning of people or objects close to the machine
- A combination of cameras and radar to identify potential hazards

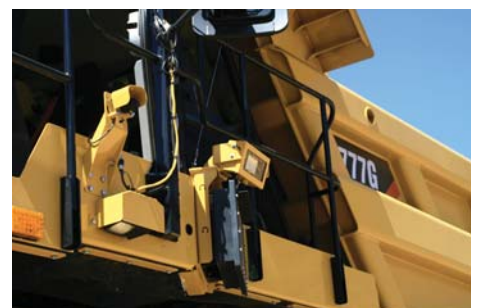
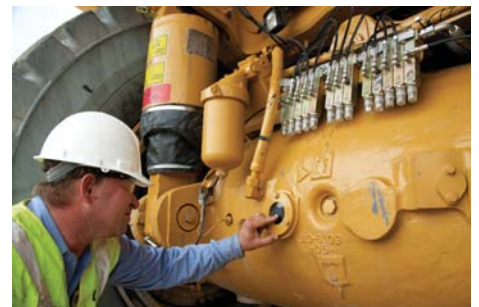



Key Features

The 777G is solidly constructed for safety.

- Rollover and Falling Object Protection is part of the cab structure
- Emergency egress available through the right-side hinged window
- Laminated glass is used in the front and left side windows
- Ground level engine shutdown
- Back-up alarm



Operator Safety

Providing features that fit your operators' needs.

- Fully adjustable and suspended seat
- Integrated three point safety belt
- Trainer seat with lap belt facilitates on-the-job task training
- Audible warnings for Events and fluid level monitoring
- Automatic derate of the engine possible on some events



Job Site Safety

Safety is a key to hauling productively.

- Speed limiting on the haul is new and more efficient than gear limiting
- Excellent visibility with mirror and lighting options
- Secondary steering in the event of a shutdown
- Speed limiting during body up operations



Comfort

The comfort of your crew will dictate their productivity and awareness on the job.

- Easy, low effort access to the cab
- Ergonomic, intuitive controls
- Left side power window
- Automatic temperature control inside the cab
- Throttle lock convenience for long uphill climbs
- The cab is spacious with window area that supports visibility
- An integrated footrest provides comfort and support
- Sound suppression has decreased noise by 50%
- The cab is isolation mounted reducing noise and vibration
- Lighting packages illuminate both to the side and front of the vehicle
- Automotive quality shifting from new transmission controls

Confidence and Control

Strong, predictable performance will help your operators achieve the lowest cost per ton.

- Automatic Retarding Control reduces operator effort and controls braking on downhill grades
- Performance and health information at a glance using well lit gauges and the Advisor Message Display
- Solid steering performance from a design that maintains its integrity
- Stopping power from fade-resistant brakes – purpose built for off road applications and the loads carried by the 777G
- Traction control is now steering sensitive and uses the service brakes to control wheel slip. The result: faster activation and improved response to wheel slip
- Visibility is excellent with extensive mirror options, large window areas and object detection

Cab layout subject to change with optional equipment.



Operator Work Environment

Productivity from comfort, confidence, control



Information

The Advisor display and VIMS software are important reporting tools that help you analyze:

- Productivity, haul road efficiency, operator skill
- Fuel use, cycle times, idle time
- Machine health and Events



As you progress towards a more sustainable business model, the Cat 777G can help.

Fuel and Emissions

- There are substantial fuel saving strategies on the 777G
- Two fuel economy modes can be adjusted to meet your daily production needs
- For the U.S. and Canada, Tier 4 Final emission controls are available two years ahead of schedule

Sound

- Operator noise is reduced by 50%
- Spectator noise levels can be lowered up to 50% with the optional "XQ" package



Component Life

- Remanufactured parts are an economical and eco-friendly alternative to new
- Extend tire life by using the TKPH/TMPH feature that calculates tire loading
- A mud protection package is available to help keep power train components clean
- Castings and box section frame construction ensure long life
- A new rear axle housing adds strength and enables axle filtration and lubrication
- Hydraulic oil filter life is extended to 1,000 hours under normal conditions
- Autostall enables quick operating temperatures for best performance and life
- Delayed Engine Shutdown prevents hot shut downs that can reduce component life



Tier 4 Final

Caterpillar's simple solution is transparent to your operators, controls emissions and increases fuel efficiency.

- Two engine-mounted diesel oxidation catalyst canisters control particulate matter
- Our NRS Technology replaces a portion of intake air with exhaust gas to control combustion temperatures and No_x production
- Precise, extremely fine atomization of fuel under all load conditions



Environmental Responsibility

The benefits are far reaching and economical



Cutting Your Fuel Costs

A strategy for lowering your cost per ton



The 777G introduces several key fuel conservation features:

- **Auto Neutral Idle** – as the 777G idles in a forward gear, the transmission will automatically slip in and out of a neutral state to avoid stalling the torque converter and raising engine rpm.
- **Engine Idle Shutdown** – when your G Series truck is in park and idles for more than a preset time, the truck will initiate engine shutdown to conserve fuel. This feature can be time adjusted or turned on or off according to your specific needs.
- **Speed Limiting** – while you can continue to gear limit your G Series trucks, Caterpillar offers speed limiting that allows the truck to travel at a more fuel efficient engine speed and gear selection.
- **Transmission Controls** – New APECS transmission controls increase fuel efficiency by maintaining momentum and speed on grade.

Economy Modes

- **Standard Economy Mode** – G Series can save fuel by adjusting engine power through this newly adjustable economy mode. Adjust the power based on your site, fleet and economic conditions. The power can be reduced from 0.5 to 15 percent.
- **Adaptive Economy Mode** – New for G Series – this economy mode requires a baseline for production from you using the Advisor display. As the truck transits the haul cycle, it is constantly evaluating its ability to meet your baseline in a reduced power rating. Where full power is needed, full power is applied, where reduced power works, reduced power is applied. It's fully automatic with no special operation required.



Performance

Efficient application of power and technology

The 777G will haul your material faster and more efficiently with increases in torque, new transmission controls and higher travel speeds.

- A 7% increase in torque puts more power to the ground
- New transmission controls carry more torque through the shifts, producing faster cycle times, most noticeably on grades
- An increase in travel speed in 7th gear also helps generate faster cycle times



Traction Control

G Series introduces benefits to your fleet when running in wet conditions by introducing a more responsive traction controls system.

- The system is steering sensitive to determine slip vs. high speed turns
- The system engages at slower speeds returning traction sooner
- The system engages sooner in the slip, potentially reducing tire wear
- The system modulates instantly between the two wheel groups for control
- Using the hydraulic service brakes facilitates the instant modulation and responsiveness

Long Term Value and Durability

Proven components for reliable performance



At Caterpillar, we know keeping your trucks running is critical to your business, that's why we use industry leading technology to ensure maximum machine availability and reliability.

Structural Strength

The backbone of the 777G is its frame. Our frames are designed for off-road integrity and are built for more than one life cycle.

- We strategically apply castings with box section construction to manage off-road stresses
- A new front frame design increases the approach angle on ramps and grades
- A new robust rear axle housing supports the truck's performance increases

Brake Performance

Cat trucks provide powerful, fade-resistant braking for your off road applications. G Series introduces new ways to extend brake life.

- Additional springs in the design reduce wear and increase service life
- All four corners have wet disc braking standard (front brake lockout no longer an option)
- Slope holding capability benefits from all wheel parking brake actuation
- Brake life can be extended by choosing the optional Cat Engine Brake
- A brake wear indicator keeps you informed of maintenance timing
- Extended life brake material is available for extreme applications

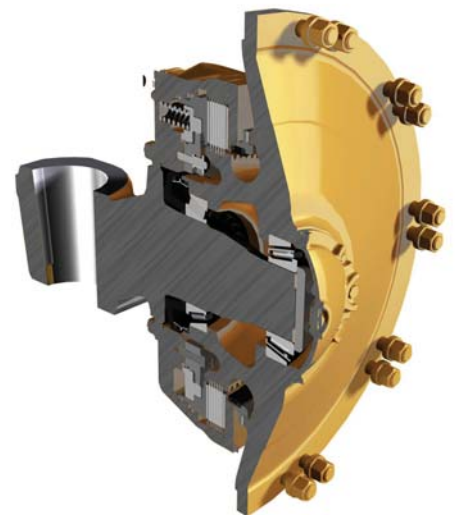
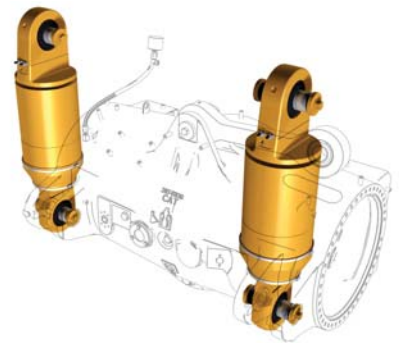



Not only proven, but continuously improving with the latest technical advantages and efficiencies.

Suspension

- Front struts use our proven king pin design for effective absorption of haul road shocks
- Rear suspension cylinders have been inverted to minimize contamination

Planetary Powershift Transmission with APECS Controls

- New APECS controls are delivering performance improvements
- Torque shift management allows the truck to power through shift points
- Part throttle shifting provides an exceptionally smooth ride
- ECPC electronically controls clutch pressures for long life

Updated Cat C32 ACERT

- For the 777G, the engine and torque converter are producing 7% more usable torque giving the truck new performance levels and quick haul cycles
- Cat MEUI™ injectors provide high pressure, fine atomization for fuel efficiency and load response
- Low pressure fuel lines from the tank to the engine simplify service
- The C32 is carefully balanced with vibration controls that reduce noise and protect against unnecessary harmonics
- Cooling is provided by either a demand fan (standard for Tier 4 Final machines) or a conventional cooling fan
- Ground level engine shutdown switch for safety
- Excellent high-altitude capability

Steering

- The steering linkage is designed to provide good feedback to the operator
- The Cat king pin front suspension system maintains steering tolerances and also tire alignment

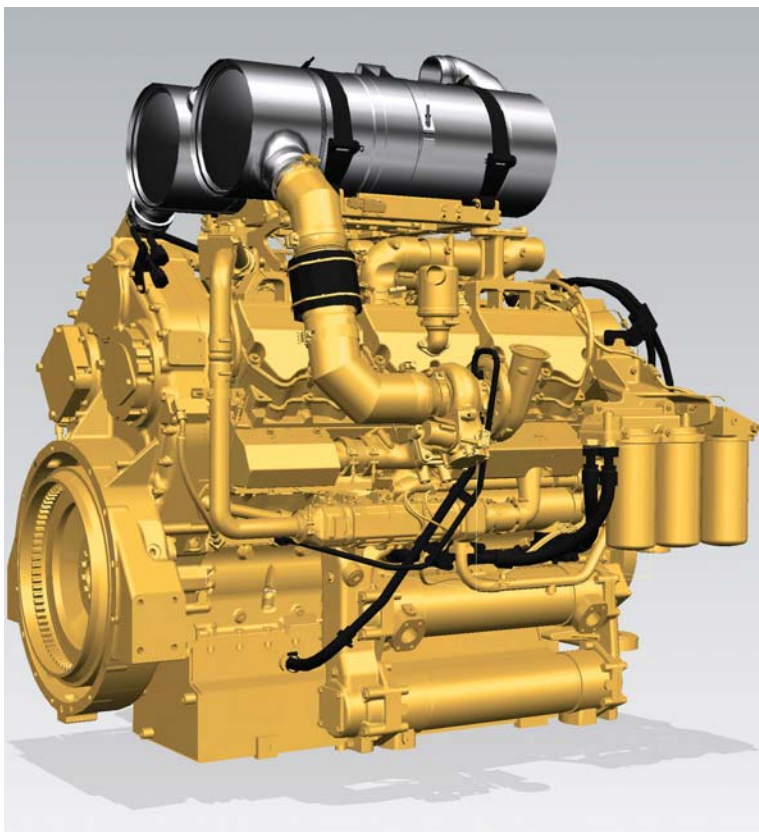



Our bodies are designed to offer you the best possible performance, longevity and value by taking into consideration tire life, the truck's center of gravity, load distribution targets and power train design.

Dual Slope Body

If your haul profile includes steep slopes, the dual slope body offers excellent material retention.

- The dual slope has a heaped capacity of 60.2 m³ (78.8 yd³) in its standard configuration
- Two sizes of side board are available to increase capacity for lighter weight materials
- 400 BNH steel on interior surfaces offers excellent wear characteristics
- Material is carried low and centered for stability
- A single 16 mm (0.62 in) steel liner option is available for this body
- A single rubber liner is available for this body



X Body

If you're feeding a crusher, the flat floor of the X Body is an excellent choice for metering material.

- The X Body also offers excellent material retention and stability
- 400 BNH and 450 BNH steel are used on internal surfaces for wear protection
- Two steel liner options are available for the X Body
- A rubber liner option is also available

The Rubber Liner

This important option will protect your truck's body in hard rock applications.

- Available for the dual slope and X Bodies
- Suppresses noise and vibration to the operator
- Suppresses spectator noise
- Prolongs body life in high impact, hard rock applications

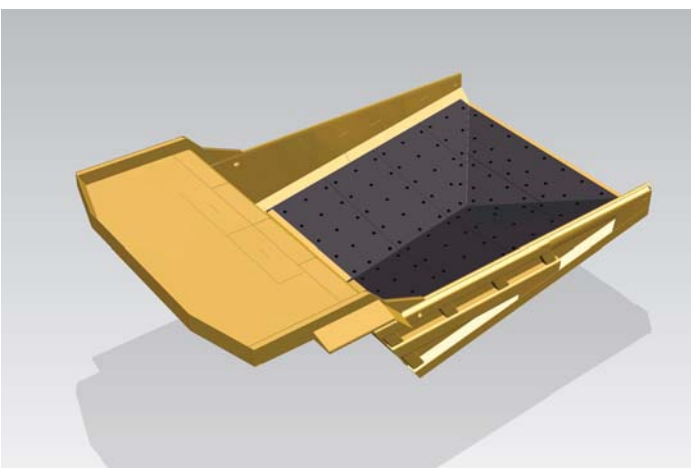



Body Options

No matter your material type

Coal Bodies

For lightweight materials, Caterpillar offers coal bodies of varying capacities.

- Material density will dictate the recommended body size
- 400 BNH steel is used for long wear life
- Capacities include:
 - 89 m³ (116 yd³)
 - 106 m³ (139 yd³)
 - 110 m³ (144 yd³)
 - 126 m³ (165 yd³)

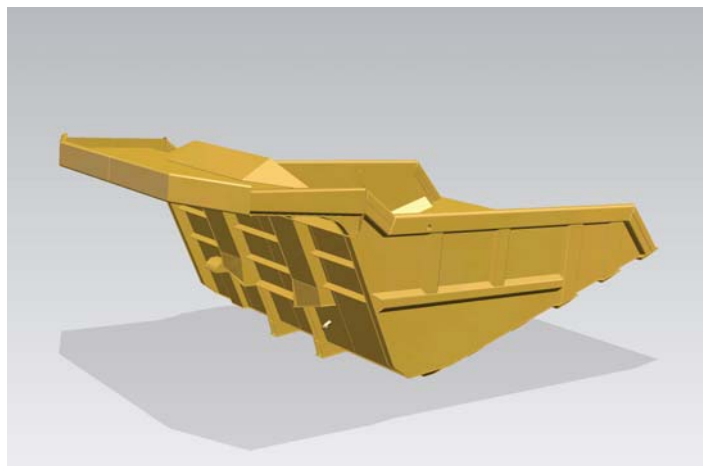
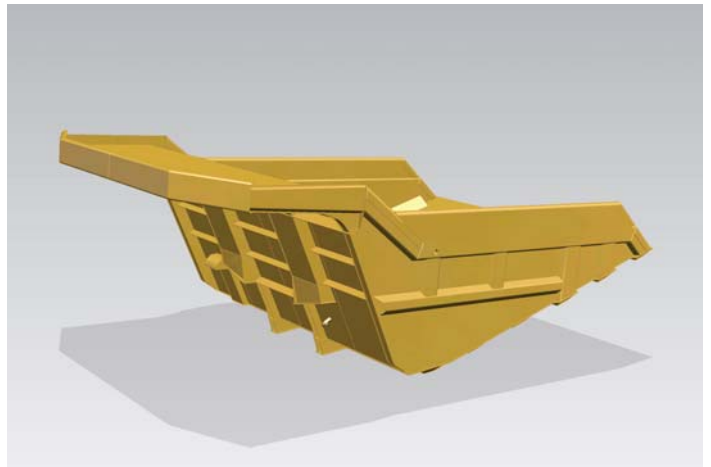

XQ Package

For your sound sensitive environments

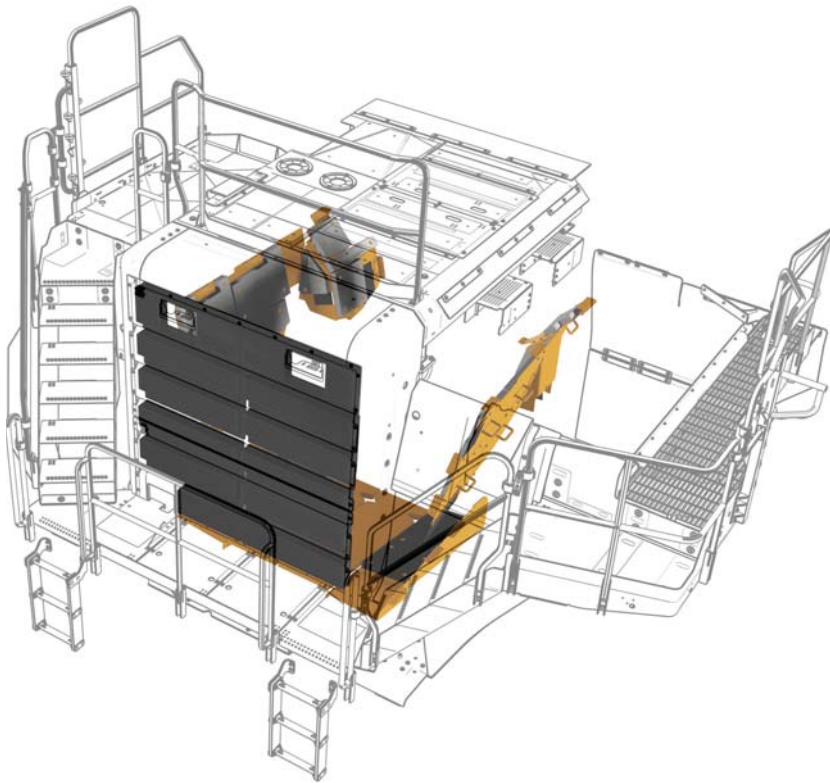

- The XQ package reduces the 777G's spectator noise level to 112 dB(A) using both the ISO 6393 and ISO 6395 test procedures. This test result has an accuracy of plus or minus 1 dB(A).
- This package includes a noise reduced Cat C32 engine, panels that enclose the engine compartment and sound reduction material within the radiator cowl.
- Sound reduction material in the cab is standard on the truck.
- Tier 2 trucks shipping outside of the U.S. and Canada will come equipped with a demand fan for the XQ package.

Mud Protection Package

For sticky, muddy environments

A mud package that encloses the engine compartment will help protect against sticky, difficult material.

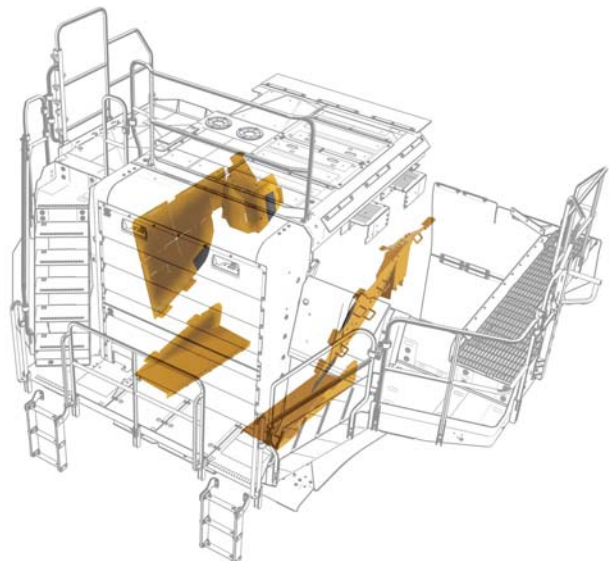

Service Convenience

Simple, more cost-effective solutions



Service Centers – Fluid Fill

You will save both time and money using the optional fluid fill service center.

- Fill and extraction for all fluids in one location
- Key pad tells employees current fluid levels
- Includes all oils, coolant and fuel
- Conveniently located at ground level
- Lighted for night time use

Service Centers – Electrical Connections

- The convenience of ground level access to VIMS data
- Ground level access to ET port
- Master disconnect switch
- Engine lockout switch
- Hydraulics lockout switch
- Breaker access

Brake Monitoring

G Series introduces several brake system updates:

- A brake wear indicator is standard
- Additional internal springs increase separation forces to increase life

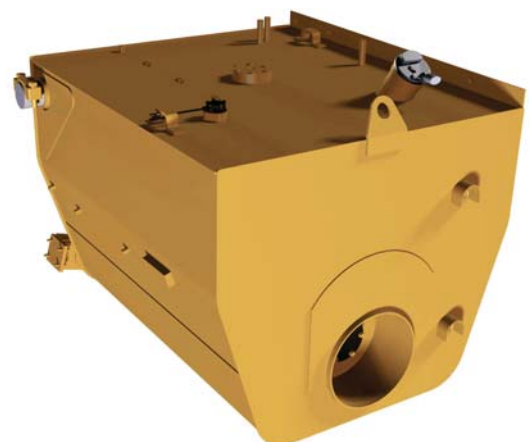

777G Off-Highway Truck Specifications

Engine (Tier 4 Final)

Engine Model	Cat® C32 ACERT™	
Engine Speed	1,800 rpm	
Gross Power – SAE J1995	765 kW	1,025 hp
Net Power – SAE J1349	683 kW	916 hp
Net Power – ISO 9249	683 kW	916 hp
Net Power – 80/1269/EEC	683 kW	916 hp
Engine Power – ISO 14396	752 kW	1,008 hp
Peak Torque Speed	1,200 rpm	
Net Torque	5286 N·m	3,899 lb-ft
Cylinders	12	
Bore	145 mm	5.7 in
Stroke	162 mm	6.4 in
Displacement	32.1 L	1,959 in ³

Engine (Tier 2 Equivalent)

Engine Model	Cat® C32 ACERT™	
Engine Speed	1,800 rpm	
Gross Power – SAE J1995	765 kW	1,025 hp
Net Power – SAE J1349	704 kW	945 hp
Net Power – ISO 9249	704 kW	945 hp
Net Power – 80/1269/EEC	704 kW	945 hp
Engine Power – ISO 14396	755 kW	1,012 hp
Peak Torque Speed	1,200 rpm	
Net Torque	5286 N·m	3,899 lb-ft
Cylinders	12	
Bore	146 mm	5.7 in
Stroke	162 mm	6.4 in
Displacement	32.1 L	1,959 in ³

- Power rating applies at 1,800 rpm when tested under the specified condition for the specified standard.
- Ratings based on SAE J1995 standard air conditions of 25° C (77° F) and 100 kPa (29.61 Hg) barometer. Power based on fuel having API gravity of 35 at 16° C (60° F) and an LHV of 42 780 kJ/kg (18,390 BTU/lb) when engine used at 30° C (86° F).
- No engine derating required up to 2286 m (7,500 ft) for Tier 4 Final and 4600 m (15,000 ft) for Tier 2 Equivalent.
- Not regulated under EU Stage IV regulations due to power rating above 560 kW (750 hp).

Transmission (Tier 4 Final)

Forward 1	10.9 km/h	6.8 mph
Forward 2	14.8 km/h	9.2 mph
Forward 3	20.1 km/h	12.5 mph
Forward 4	27.2 km/h	16.9 mph
Forward 5	36.9 km/h	22.9 mph
Forward 6	49.4 km/h	30.7 mph
Forward 7	67.1 km/h	41.7 mph
Reverse	12.4 km/h	7.7 mph

Transmission (Tier 2 Equivalent)

Forward 1	10.9 km/h	6.8 mph
Forward 2	14.8 km/h	9.2 mph
Forward 3	20.1 km/h	12.5 mph
Forward 4	27.2 km/h	16.9 mph
Forward 5	36.9 km/h	22.9 mph
Forward 6	49.4 km/h	30.7 mph
Forward 7	67.1 km/h	41.7 mph
Reverse	12.4 km/h	7.7 mph

- Maximum travel speeds with standard 27.00R49 (E4) tires.

Final Drives

Differential Ratio	2.736:1
Planetary Ratio	7.0:1
Total Reduction Ratio	19.1576:1

Brakes

Brake Surface Area – Front	40 846 cm ²	6,331 in ²
Brake Surface Area – Rear	102 116 cm ²	15,828 in ²
Brake Standards	ISO 3450:1996	

Body Hoists (Tier 4 Final)

Pump Flow – High Idle	458 L/min	120.9 gal/min
Relief Valve Setting – Raise	18 950 kPa	2,750 psi
Relief Valve Setting – Lower	3450 kPa	500 psi
Body Raise Time – High Idle	15 seconds	
Body Lower Time – Float	13 seconds	
Body Lower Time – High Idle	13 seconds	

Body Hoists (Tier 2 Equivalent)

Pump Flow – High Idle	458 L/min	120.9 gal/min
Relief Valve Setting – Raise	18 950 kPa	2,750 psi
Relief Valve Setting – Lower	3450 kPa	500 psi
Body Raise Time – High Idle	15 seconds	
Body Lower Time – Float	13 seconds	
Body Lower Time – High Idle	13 seconds	

Capacity – Dual Slope – 100% Fill Factor

Struck	41.9 m ³	54.8 yd ³
Heaped 2:1 (SAE)	60.2 m ³	78.8 yd ³

Capacity – X Body – 100% Fill Factor

Struck	43.1 m ³	56.3 yd ³
Heaped 2:1 (SAE)	64.1 m ³	83.8 yd ³

Capacity – Coal Bodies – 100% Fill Factor

SAE 2:1 for use with material densities of 1160 kg/m ³ (1,950 lb/yd ³)	89 m ³	116 yd ³
SAE 2:1 for use with material densities of 1040-1160 kg/m ³ (1,750-1,950 lb/yd ³)	106 m ³	139 yd ³
SAE 2:1 for use with material densities of 950-1040 kg/m ³ (1,600-1,750 lb/yd ³)	110 m ³	144 yd ³
SAE 2:1 for use with material densities less than 950 kg/m ³ (1,600 lb/yd ³)	126 m ³	165 yd ³

Weight Distributions – Approximate

Front Axle – Empty	46%
Front Axle – Loaded	33%
Rear Axle – Empty	54%
Rear Axle – Loaded	67%

Suspension

Empty Loaded Cylinder Stroke Front	74.7 mm	2.9 in
Empty Loaded Cylinder Stroke Rear	66 mm	2.5 in
Rear Axle Oscillation	5.4°	

Sound

Sound Standards

- The operator Equivalent Sound Pressure Level (Leq) is 73 dB(A) when SAE J1166 FEB2008 is used to measure the value for an enclosed cab. This is a work cycle sound exposure level. The cab was properly installed and maintained. The test was conducted with the cab doors and the cab windows closed.
- The exterior sound pressure level for the standard machine measured at a distance of 15 m (49 ft) according to the test procedures specified in SAE J88:2008, mid-gear moving operation is 83 dB(A) for Tier 4 Final trucks and 84 dB(A) for Tier 2 Equivalent.
- Hearing protection may be needed when operating with an open operator station and cab (when not properly maintained or doors/windows open) for extended periods or in a noisy environment.

Service Refill Capacities

Fuel Tank	1136 L	300 gal
Fuel Tank	1325 L	350 gal
Cooling System – Tier 4 Final	240 L	63.4 gal
Cooling System – Tier 2 Equivalent	228 L	60.2 gal
Crankcase	109 L	28.7 gal
Differentials	227 L	59.9 gal
Final Drives (each)	76 L	20 gal
Steering System (includes tank)	53.6 L	14.1 gal
Brake Hoist System (includes tank)	444 L	117 gal
Brake Hoist System	322 L	85 gal
Torque Converter/ Transmission System	138.5 L	36.5 gal

Steering

Steering Standards	SAE J1511 FEB94 ISO 5010:1992	
Steer Angle	30.5°	
Turning Diameter – Front	25.3 m	83 ft
Turning Circle Clearance Diameter	28.4 m	93 ft

Tires

Standard Tire	27.00R49 (E4)
---------------	---------------

- Productive capabilities of the 777G truck are such that, under certain job conditions, TKPH (TMPH) capabilities of standard or optional tires could be exceeded and, therefore, limit production.
- Caterpillar recommends the customer evaluate all job conditions and consult the tire manufacturer for proper tire selection.

ROPS

ROPS/FOPS Standards

- ROPS (Rollover Protective Structure) for cab offered by Caterpillar meets ISO 3471:2008 ROPS criteria.
- FOPS (Falling Objects Protective Structure) meets ISO 3449:2005 Level II FOPS criteria.

777G Off-Highway Truck Specifications

Weight/Payload Calculation – Tier 4 Final Examples

777G – X Body (flat floor)		327-0400 Body System		363-5111 Body + Steel Liner		363-5112 Body + HD Steel Liner		363-5113 Body + Rubber Liner	
Base – Floor/Sidewall/Frontwall	mm	20/10/12		20/10/12		20/10/12		20/10/12	
	in	(0.79/0.39/0.47)		(0.79/0.39/0.47)		(0.79/0.39/0.47)		(0.79/0.39/0.47)	
Liner – Floor/Sidewall/Frontwall	mm	NA		12/10/6		16/10/10		102/10/10	
	in			(0.47/0.39/0.24)		(0.63/0.39/0.39)		(4.02/0.39/0.39)	
Payload Capacity		64.1 m³	(83.8 yd³)	63.5 m³	(83.1 yd³)	63.3 m³	(82.8 yd³)	60.9 m³	(79.7 yd³)
Target Gross Machine Weight	kg (lb)	164 654	(363,000)	164 654	(363,000)	164 654	(363,000)	164 654	(363,000)
Empty Chassis Weight	kg (lb)	51 286	(113,085)	51 286	(113,085)	51 286	(113,085)	51 286	(113,085)
Body System Weight	kg (lb)	15 878	(35,011)	20 564	(45,344)	22 094	(48,717)	22 938	(50,578)
Empty Machine Weight	kg (lb)	67 164	(148,096)	71 850	(158,428)	73 380	(161,802)	74 224	(163,663)
Attachments									
Fuel Tank Size	L (gal)	1136	(300)	1136	(300)	1136	(300)	1136	(300)
Fuel Tank – 100% Fill	kg (lb)	955	(2,106)	955	(2,106)	955	(2,106)	955	(2,106)
Debris Allowance – 2%	kg (lb)	1363	(3,004)	1456	(3,211)	1487	(3,278)	1504	(3,315)
Empty Operating Weight**	kg (lb)	68 119	(150,202)	72 805	(160,535)	74 335	(163,908)	75 179	(165,770)
Target Payload*	kg (lb)	95 172	(209,794)	90 393	(199,254)	88 832	(195,813)	87 971	(193,915)
Target Payload*	tonnes (tons)	95.2	(104.9)	90.4	(99.6)	88.8	(97.9)	88.0	(97.0)
10/10/20 Policy*									
Nominal Payload – 100%	kg (lb)	95 172	(209,794)	90 393	(199,254)	88 832	(195,813)	87 971	(193,915)
Maximum Working Payload – 110%	kg (lb)	104 690	(230,773)	99 432	(219,180)	97 715	(215,395)	96 768	(213,307)
Not to Exceed Payload – 120%	kg (lb)	114 207	(251,752)	108 471	(239,105)	106 599	(234,976)	105 565	(232,698)
Maximum Gross Machine Weight*	kg (lb)	182 326	(401,955)	181 276	(399,640)	180 934	(398,884)	180 744	(398,468)

777G – Dual Slope		242-3170 Body System		277-3212 Body + Steel Liner		277-3213 Body + Rubber Liner	
Base – Floor/Sidewall/Frontwall	mm	20/10/12		20/10/12		20/10/12	
	in	(0.79/0.39/0.47)		(0.79/0.39/0.47)		(0.79/0.39/0.47)	
Liner – Floor/Sidewall/Frontwall	mm	None		16/8/8		102/10/10	
	in			(0.63/0.31/0.31)		(4.02/0.39/0.39)	
Payload Capacity		60.1 m³	(78.6 yd³)	59.5 m³	(77.8 yd³)	57.0 m³	(74.6 yd³)
Target Gross Machine Weight	kg (lb)	164 654	(363,000)	164 654	(363,000)	164 654	(363,000)
Empty Chassis Weight	kg (lb)	51 286	(113,085)	51 286	(113,085)	51 286	(113,085)
Body System Weight	kg (lb)	16 075	(35,445)	21 770	(48,003)	23 017	(50,752)
Empty Machine Weight	kg (lb)	67 361	(148,530)	73 056	(161,088)	74 303	(163,837)
Attachments							
Fuel Tank Size	L (gal)	1136	(300)	1136	(300)	1136	(300)
Fuel Tank – 100% Fill	kg (lb)	955	(2,106)	955	(2,106)	955	(2,106)
Debris Allowance – 2%	kg (lb)	1367	(3,013)	1480	(3,264)	1505	(3,319)
Empty Operating Weight**	kg (lb)	68 316	(150,637)	74 011	(163,194)	75 258	(165,944)
Target Payload*	kg (lb)	94 971	(209,351)	89 163	(196,542)	87 891	(193,737)
Target Payload*	tonnes (tons)	95.0	(105.9)	89.2	(98.3)	87.9	(96.9)
10/10/20 Policy							
Nominal Payload – 100%	kg (lb)	94 971	(209,351)	89 163	(196,542)	87 891	(193,737)
Maximum Working Payload – 110%	kg (lb)	104 469	(230,286)	98 079	(216,196)	96 680	(213,111)
Not to Exceed Payload – 120%	kg (lb)	113 966	(251,221)	106 995	(235,850)	105 469	(232,485)
Maximum Gross Machine Weight*	kg (lb)	182 282	(401,857)	181 006	(399,045)	180 727	(398,429)

*Refer to Caterpillar 10/10/20 overload policy.

**Includes weight of all attachments.

Weight/Payload Calculation – Tier 4 Final Examples

777G – Gateless Coal Body		321-5400 Body System		321-5410 Body System		321-5500 Body System		321-5500 Body System	
Base – Floor/Sidewall/Frontwall	mm in	14/10/10 (0.55/0.39/0.39)		14/10/10 (0.55/0.39/0.39)		14/10/10 (0.55/0.39/0.39)		14/10/10 (0.55/0.39/0.39)	
Liner – Floor/Sidewall/Frontwall	mm in	None		None		None		None	
Payload Capacity		89.3 m³	(116.8 yd³)	106 m³	(138.6 yd³)	110 m³	(143.9 yd³)	125.9 m³	(164.7 yd³)
Target Gross Machine Weight	kg (lb)	164 654	(363,000)	164 654	(363,000)	164 654	(363,000)	164 654	(363,000)
Empty Chassis Weight	kg (lb)	51 286	(113,085)	51 286	(113,085)	51 286	(113,085)	51 286	(113,085)
Body System Weight	kg (lb)	16 710	(36,839)	17 826	(39,300)	17 712	(39,048)	18 915	(41,700)
Empty Machine Weight	kg (lb)	67 996	(149,924)	69 112	(152,385)	68 998	(152,133)	70 200	(154,785)
Attachments									
Fuel Tank Size	L (gal)	1136	(300)	1136	(300)	1136	(300)	1136	(300)
Fuel Tank – 100% Fill	kg (lb)	955	(2,106)	955	(2,106)	955	(2,106)	955	(2,106)
Debris Allowance – 2%	kg (lb)	1379	(3,041)	1402	(3,090)	1399	(3,085)	1423	(3,138)
Empty Operating Weight**	kg (lb)	68 951	(152,030)	70 067	(154,491)	69 953	(154,239)	71 156	(156,891)
Target Payload*	kg (lb)	94 324	(207,929)	93 185	(205,419)	93 302	(205,676)	92 075	(202,971)
Target Payload*	tonnes (tons)	94.3	(104.0)	93.2	(102.7)	93.3	(102.8)	92.1	(101.5)
10/10/20 Policy									
Target Payload – 100%	kg (lb)	94 324	(207,929)	93 185	(205,419)	93 302	(205,676)	92 075	(202,971)
Target Payload – 110%	kg (lb)	103 756	(228,722)	102 504	(225,961)	102 632	(226,244)	101 282	(223,268)
Target Payload – 120%	kg (lb)	113 189	(249,515)	111 822	(246,503)	111 962	(246,811)	110 490	(243,565)
Maximum Gross Machine Weight*	kg (lb)	182 140	(401,545)	181 890	(400,994)	181 915	(401,050)	181 646	(400,456)

*Refer to Caterpillar 10/10/20 overload policy.

**Includes weight of all attachments.

777G Off-Highway Truck Specifications

Weight/Payload Calculation – Tier 2 Equivalent Examples

777G – X Body (flat floor)		327-0400 Body System		363-5111 Body + Steel Liner		363-5112 Body + HD Steel Liner		363-5113 Body + Rubber Liner	
Base – Floor/Sidewall/Frontwall	mm in	20/10/12 (0.79/0.39/0.47)		20/10/12 (0.79/0.39/0.47)		20/10/12 (0.79/0.39/0.47)		20/10/12 (0.79/0.39/0.47)	
Liner – Floor/Sidewall/Frontwall	mm in	NA		12/10/6 (0.47/0.39/0.24)		16/10/10 (0.63/0.39/0.39)		102/10/10 (4.02/0.39/0.39)	
Payload Capacity		64.1 m³ (83.8 yd³)		63.5 m³ (83.1 yd³)		63.3 m³ (82.8 yd³)		60.9 m³ (79.7 yd³)	
Target Gross Machine Weight	kg (lb)	164 654 (363,000)	164 654 (363,000)	164 654 (363,000)	164 654 (363,000)	164 654 (363,000)	164 654 (363,000)	164 654 (363,000)	164 654 (363,000)
Empty Chassis Weight	kg (lb)	50 893 (112,219)	50 893 (112,219)	50 893 (112,219)	50 893 (112,219)	50 893 (112,219)	50 893 (112,219)	50 893 (112,219)	50 893 (112,219)
Body System Weight	kg (lb)	15 878 (35,011)	20 564 (45,344)	22 094 (48,717)	22 094 (48,717)	22 094 (48,717)	22 938 (50,578)	22 938 (50,578)	22 938 (50,578)
Empty Machine Weight	kg (lb)	66 771 (147,230)	71 457 (157,563)	72 987 (160,936)	72 987 (160,936)	72 987 (160,936)	73 831 (162,797)	73 831 (162,797)	73 831 (162,797)
Attachments									
Fuel Tank Size	L (gal)	1136 (300)	1136 (300)	1136 (300)	1136 (300)	1136 (300)	1136 (300)	1136 (300)	1136 (300)
Fuel Tank – 100% Fill	kg (lb)	955 (2,106)	955 (2,106)	955 (2,106)	955 (2,106)	955 (2,106)	955 (2,106)	955 (2,106)	955 (2,106)
Debris Allowance – 2%	kg (lb)	1355 (2,987)	1448 (3,192)	1479 (3,261)	1479 (3,261)	1479 (3,261)	1496 (3,298)	1496 (3,298)	1496 (3,298)
Empty Operating Weight**	kg (lb)	67 726 (149,336)	72 412 (159,669)	73 942 (163,043)	73 942 (163,043)	73 942 (163,043)	74 786 (164,904)	74 786 (164,904)	74 786 (164,904)
Target Payload*	kg (lb)	95 573 (210,677)	90 793 (200,138)	89 233 (196,696)	89 233 (196,696)	89 233 (196,696)	88 372 (194,798)	88 372 (194,798)	88 372 (194,798)
Target Payload*	tonnes (tons)	95.6 (105.3)	90.8 (100.1)	89.2 (98.3)	89.2 (98.3)	89.2 (98.3)	88.4 (97.4)	88.4 (97.4)	88.4 (97.4)
10/10/20 Policy*									
Nominal Payload – 100%	kg (lb)	95 573 (210,677)	90 793 (200,138)	89 233 (196,696)	89 233 (196,696)	89 233 (196,696)	88 372 (194,798)	88 372 (194,798)	88 372 (194,798)
Maximum Working Payload – 110%	kg (lb)	105 130 (231,744)	99 872 (220,151)	98 156 (216,366)	98 156 (216,366)	98 156 (216,366)	97 209 (214,278)	97 209 (214,278)	97 209 (214,278)
Not to Exceed Payload – 120%	kg (lb)	114 687 (252,812)	108 952 (240,165)	107 079 (236,036)	107 079 (236,036)	107 079 (236,036)	106 046 (233,758)	106 046 (233,758)	106 046 (233,758)
Maximum Gross Machine Weight*	kg (lb)	182 414 (402,149)	181 364 (399,834)	181 021 (399,078)	181 021 (399,078)	181 021 (399,078)	180 832 (398,662)	180 832 (398,662)	180 832 (398,662)
777G – Dual Slope									
777G – Dual Slope		242-3170 Body System		277-3212 Body + Steel Liner		277-3213 Body + Rubber Liner			
Base – Floor/Sidewall/Frontwall	mm in	20/10/12 (0.79/0.39/0.47)		20/10/12 (0.79/0.39/0.47)		20/10/12 (0.79/0.39/0.47)			
Liner – Floor/Sidewall/Frontwall	mm in	None		16/8/8 (0.63/0.31/0.31)		102/10/10 (4.02/0.39/0.39)			
Payload Capacity		60.1 m³ (78.6 yd³)		59.5 m³ (77.8 yd³)		57.0 m³ (74.6 yd³)			
Target Gross Machine Weight	kg (lb)	164 654 (363,000)	164 654 (363,000)	164 654 (363,000)	164 654 (363,000)	164 654 (363,000)	164 654 (363,000)	164 654 (363,000)	164 654 (363,000)
Empty Chassis Weight	kg (lb)	50 893 (112,219)	50 893 (112,219)	50 893 (112,219)	50 893 (112,219)	50 893 (112,219)	50 893 (112,219)	50 893 (112,219)	50 893 (112,219)
Body System Weight	kg (lb)	16 075 (32,954)	21 770 (48,003)	23 017 (50,752)	23 017 (50,752)	23 017 (50,752)	23 017 (50,752)	23 017 (50,752)	23 017 (50,752)
Empty Machine Weight	kg (lb)	66 968 (147,664)	72 663 (160,222)	73 910 (162,972)	73 910 (162,972)	73 910 (162,972)	73 910 (162,972)	73 910 (162,972)	73 910 (162,972)
Attachments									
Fuel Tank Size	L (gal)	1136 (300)	1136 (300)	1136 (300)	1136 (300)	1136 (300)	1136 (300)	1136 (300)	1136 (300)
Fuel Tank – 100% Fill	kg (lb)	955 (2,106)	955 (2,106)	955 (2,106)	955 (2,106)	955 (2,106)	955 (2,106)	955 (2,106)	955 (2,106)
Debris Allowance – 2%	kg (lb)	1359 (2,995)	1473 (3,247)	1498 (3,302)	1498 (3,302)	1498 (3,302)	1498 (3,302)	1498 (3,302)	1498 (3,302)
Empty Operating Weight**	kg (lb)	67 923 (149,771)	73 618 (162,328)	74 865 (165,078)	74 865 (165,078)	74 865 (165,078)	74 865 (165,078)	74 865 (165,078)	74 865 (165,078)
Target Payload*	kg (lb)	95 372 (210,234)	89 563 (197,425)	88 291 (194,620)	88 291 (194,620)	88 291 (194,620)	88 291 (194,620)	88 291 (194,620)	88 291 (194,620)
Target Payload*	tonnes (tons)	95.4 (105.1)	89.6 (98.7)	88.3 (97.3)	88.3 (97.3)	88.3 (97.3)	88.3 (97.3)	88.3 (97.3)	88.3 (97.3)
10/10/20 Policy									
Nominal Payload – 100%	kg (lb)	95 372 (210,234)	89 563 (197,425)	88 291 (194,620)	88 291 (194,620)	88 291 (194,620)	88 291 (194,620)	88 291 (194,620)	88 291 (194,620)
Maximum Working Payload – 110%	kg (lb)	104 909 (231,257)	98 519 (217,168)	97 120 (214,083)	97 120 (214,083)	97 120 (214,083)	97 120 (214,083)	97 120 (214,083)	97 120 (214,083)
Not to Exceed Payload – 120%	kg (lb)	114 446 (252,280)	107 476 (236,910)	105 949 (233,545)	105 949 (233,545)	105 949 (233,545)	105 949 (233,545)	105 949 (233,545)	105 949 (233,545)
Maximum Gross Machine Weight*	kg (lb)	182 370 (402,051)	181 094 (399,238)	180 815 (398,623)	180 815 (398,623)	180 815 (398,623)	180 815 (398,623)	180 815 (398,623)	180 815 (398,623)

*Refer to Caterpillar 10/10/20 overload policy.

**Includes weight of all attachments.

Weight/Payload Calculation – Tier 2 Equivalent Examples

777G – Gateless Coal Body		321-5400 Body System		321-5410 Body System		321-5500 Body System		321-5500 Body System	
Base – Floor/Sidewall/Frontwall	mm in	14/10/10 (0.55/0.39/0.39)		14/10/10 (0.55/0.39/0.39)		14/10/10 (0.55/0.39/0.39)		14/10/10 (0.55/0.39/0.39)	
Liner – Floor/Sidewall/Frontwall	mm in	None		None		None		None	
Payload Capacity		89.3 m³	(116.8 yd³)	106 m³	(138.6 yd³)	110 m³	(143.9 yd³)	125.9 m³	(164.7 yd³)
Target Gross Machine Weight	kg (lb)	164 654	(363,000)	164 654	(363,000)	164 654	(363,000)	164 654	(363,000)
Empty Chassis Weight	kg (lb)	50 893	(112,219)	50 893	(112,219)	50 893	(112,219)	50 893	(112,219)
Body System Weight	kg (lb)	16 710	(36,839)	17 826	(39,300)	17 712	(39,048)	18 915	(41,700)
Empty Machine Weight	kg (lb)	67 603	(149,058)	68 719	(151,519)	68 605	(151,267)	69 808	(153,919)
Attachments									
Fuel Tank Size	L (gal)	1136	(300)	1136	(300)	1136	(300)	1136	(300)
Fuel Tank – 100% Fill	kg (lb)	955	(2,106)	955	(2,106)	955	(2,106)	955	(2,106)
Debris Allowance – 2%	kg (lb)	1371	(3,023)	1394	(3,073)	1391	(3,067)	1415	(3,121)
Empty Operating Weight**	kg (lb)	68 558	(151,164)	69 675	(153,625)	69 560	(153,373)	70 763	(156,025)
Target Payload*	kg (lb)	94 724	(208,812)	93 586	(206,302)	93 702	(206,559)	92 475	(203,854)
Target Payload*	tonnes (tons)	94.7	(104.4)	93.6	(103.2)	93.7	(103.3)	92.5	(101.9)
10/10/20 Policy									
Target Payload – 100%	kg (lb)	94 724	(208,812)	93 586	(206,302)	93 702	(206,559)	92 475	(203,854)
Target Payload – 110%	kg (lb)	104 197	(229,693)	102 944	(226,932)	103 073	(227,215)	101 723	(224,239)
Target Payload – 120%	kg (lb)	113 669	(250,575)	112 303	(247,562)	112 443	(247,871)	110 971	(244,625)
Maximum Gross Machine Weight*	kg (lb)	182 228	(401,739)	181 978	(401,188)	182 003	(401,244)	181 734	(400,650)

*Refer to Caterpillar 10/10/20 overload policy.

**Includes weight of all attachments.

777G Off-Highway Truck Specifications

10/10/20 Payload Management Policy for Optimal Machine Life

The ideal hauling strategy that maximizes machine and machine component life is to *keep the mean of all payloads at or below the machine's rated target payload.*

- 90% of loads should fall into this range
- No more than 10% of loads should exceed 10% of the target payload
- No loads should be above 20% of the target payload

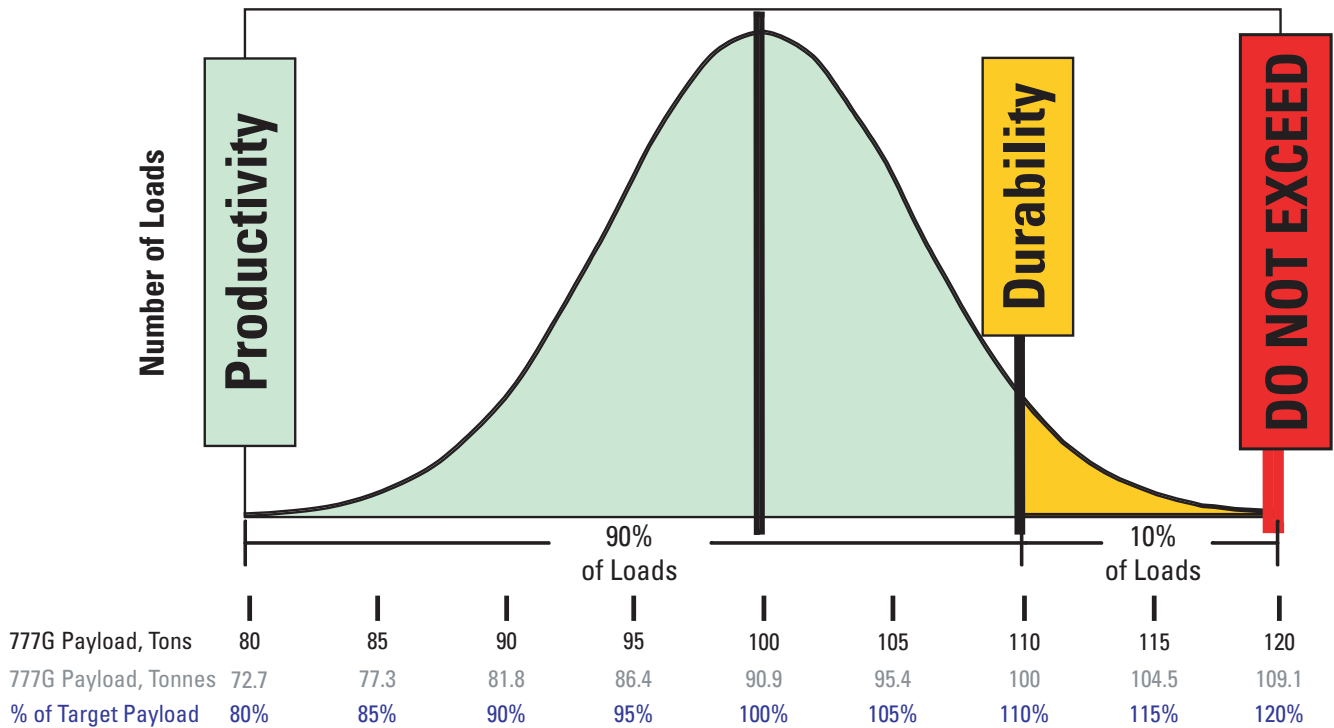

Dimensions

All dimensions are approximate.

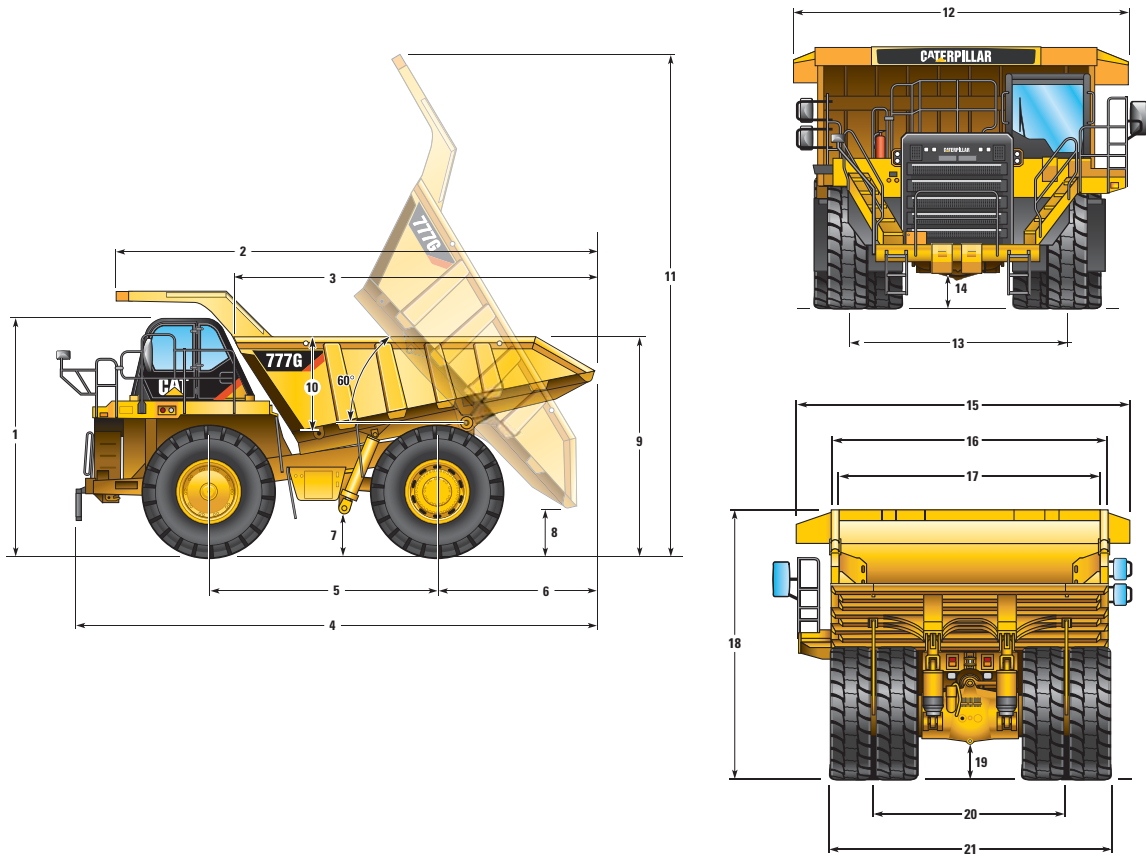

	Dual Slope		X Body		Coal Body 1		Coal Body 2	
1 Height to Top of ROPS	4730 mm	15.50 ft	4730 mm	15.50 ft	4730 mm	15.50 ft	4730 mm	15.50 ft
2 Overall Body Length	9830 mm	32.20 ft	10 070 mm	33.04 ft	10 274 mm	33.71 ft	10 445 mm	34.27 ft
3 Inside Body Length	6580 mm	21.50 ft	7037 mm	23.09 ft	7562 mm	24.81 ft	7734 mm	25.37 ft
4 Overall Length	10 535 mm	34.50 ft	10 758 mm	35.30 ft	10 968 mm	35.98 ft	11 140 mm	36.55 ft
5 Wheelbase	4560 mm	14.90 ft	4560 mm	14.96 ft	4560 mm	14.96 ft	4560 mm	14.96 ft
6 Rear Axle to Tail	3062 mm	10.00 ft	3263 mm	10.71 ft	3473 mm	11.39 ft	3644 mm	11.96 ft
7 Ground Clearance	896 mm	2.90 ft	896 mm	2.94 ft	896 mm	2.94 ft	896 mm	2.94 ft
8 Dump Clearance	965 mm	3.10 ft	893 mm	2.93 ft	935 mm	3.07 ft	821 mm	2.69 ft
9 Loading Height – Empty	4380 mm	14.30 ft	4429 mm	14.53 ft	4851 mm	15.92 ft	5321 mm	17.46 ft
10 Inside Body Depth – Maximum	1895 mm	6.20 ft	1777 mm	5.83 ft	2223 mm	7.29 ft	2693 mm	8.84 ft
11 Overall Height – Body Raised	9953 mm	32.60 ft	10 071 mm	33.04 ft	10 319 mm	33.85 ft	10 319 mm	33.85 ft
12 Operating Width	6687 mm	21.90 ft	6687 mm	21.94 ft	6706 mm	22.00 ft	6706 mm	22.00 ft
13 Front Tire Width	4170 mm	13.60 ft	4170 mm	13.68 ft	4170 mm	13.68 ft	4170 mm	13.68 ft
14 Engine Guard Clearance	864 mm	2.80 ft	864 mm	2.83 ft	864 mm	2.83 ft	864 mm	2.83 ft
15 Overall Canopy Width	6200 mm	20.30 ft	6200 mm	20.34 ft	6404 mm	21.01 ft	6404 mm	21.01 ft
16 Outside Body Width	5524 mm	18.10 ft	5682 mm	18.64 ft	6365 mm	20.88 ft	6368 mm	20.89 ft
17 Inside Body Width	5200 mm	17.00 ft	5450 mm	17.88 ft	6150 mm	20.18 ft	6150 mm	20.18 ft
18 Front Canopy Height	5200 mm	17.00 ft	5370 mm	17.62 ft	5840 mm	19.16 ft	5840 mm	19.16 ft
19 Rear Axle Clearance	902 mm	2.90 ft	902 mm	2.96 ft	902 mm	2.96 ft	902 mm	2.96 ft
20 Rear Dual Tire Width	3576 mm	11.70 ft	3576 mm	11.73 ft	3576 mm	11.73 ft	3576 mm	11.73 ft
21 Overall Tire Width	5223 mm	17.10 ft	5223 mm	17.14 ft	5223 mm	17.14 ft	5223 mm	17.14 ft

777G Off-Highway Truck Specifications

Retarding Performance (Tier 4 Final)

To determine retarding performance: Add lengths of all downhill segments and, using this total, refer to proper retarding chart. Read from gross weight down to the percent effective grade. Effective grade equals actual % grade minus 1% for each 10 kg/t (20 lb/ton) of rolling resistance. From this weight-effective grade point, read horizontally to the curve with the highest obtainable gear, then down to maximum descent speed brakes can properly handle without exceeding cooling capacity. The following charts are based on these conditions: 32° C (90° F) ambient temperature, at sea level, with 27.00R49 (E4) tires.

NOTE: Select the proper gear to maintain engine rpm at the highest possible level, without overspeeding the engine. If cooling oil overheats, reduce ground speed to allow transmission to shift to the next lower speed range.

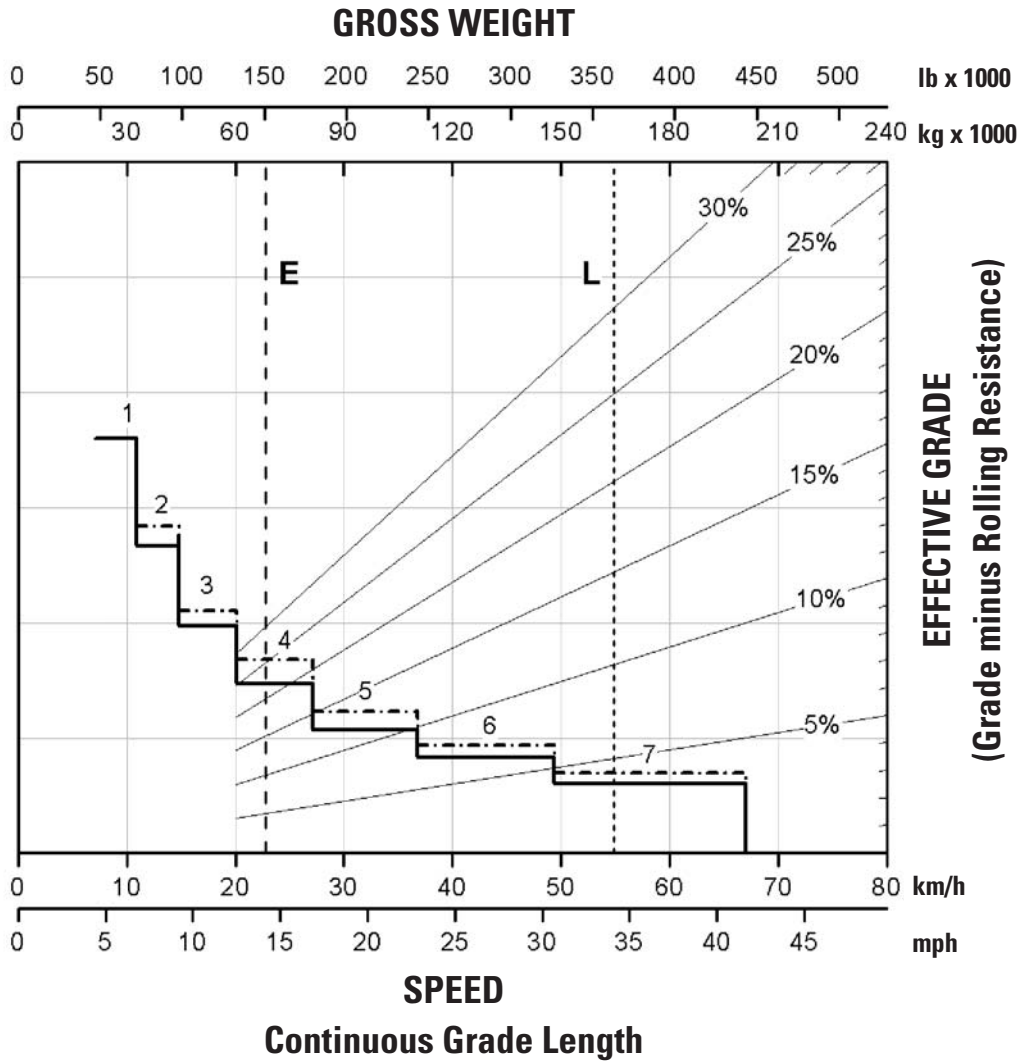

Retarding Performance (Tier 4 Final)

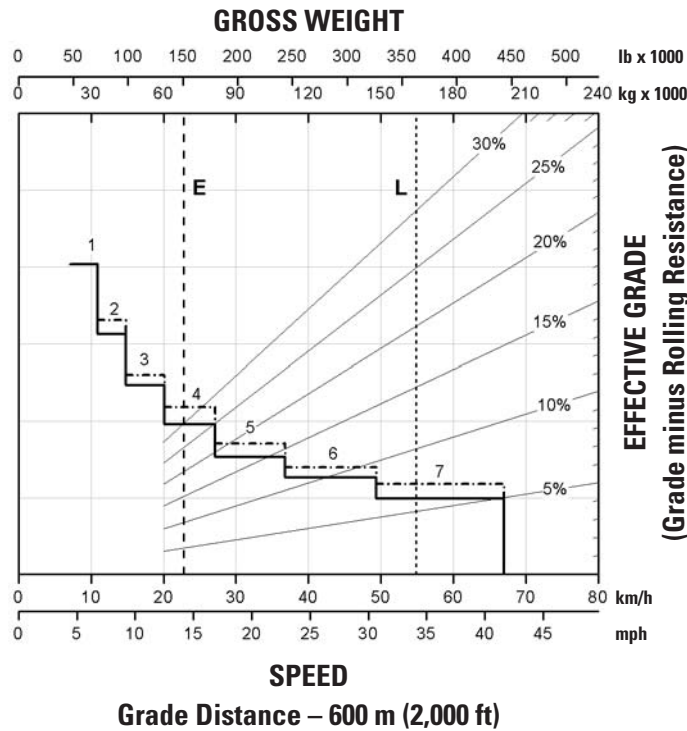
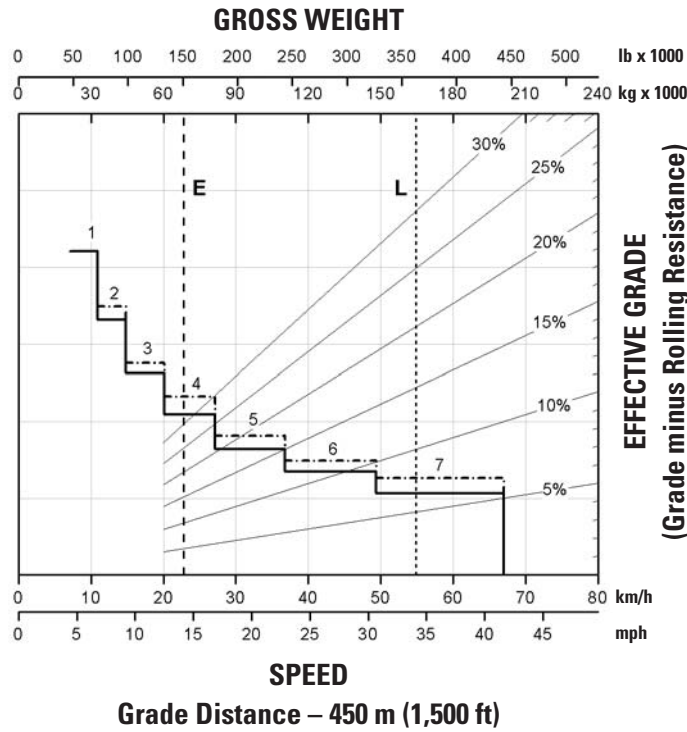

----- Engine Brake

777G Off-Highway Truck Specifications

Retarding Performance (Tier 4 Final)

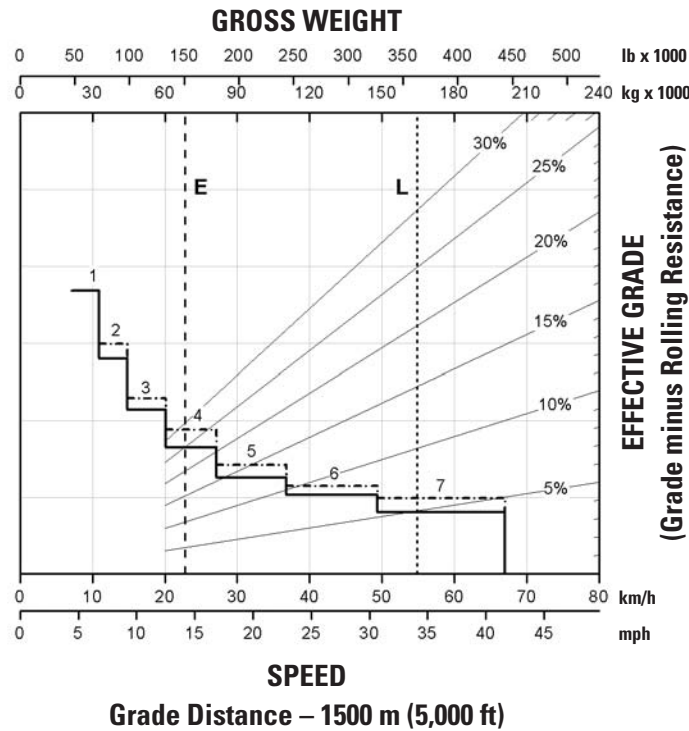
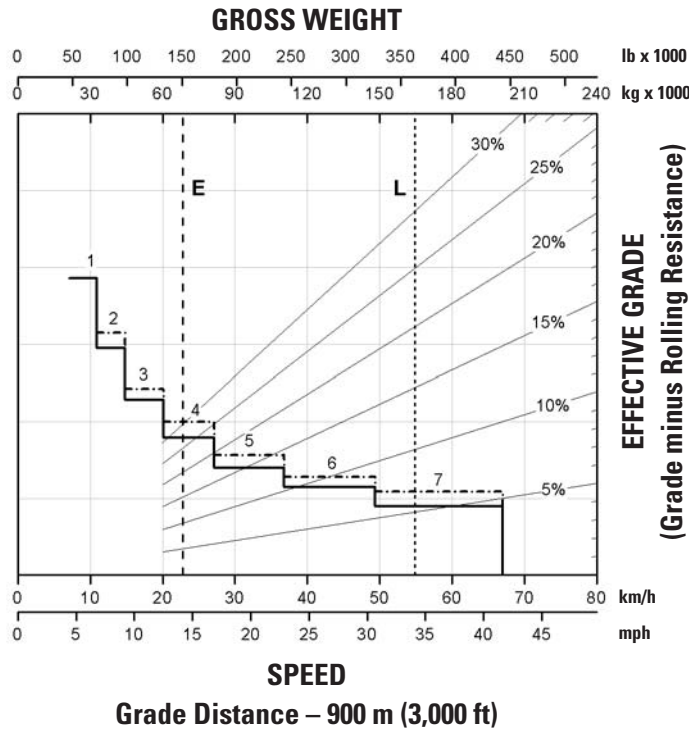

----- Engine Brake

Gradeability/Speed/Rimpull (Tier 4 Final)

To determine gradeability performance: Read from gross weight down to the percent of total resistance. Total resistance equals actual percent grade plus 1% for each 10 kg/t (20 lb/ton) of rolling resistance. From this weight-resistance point, read horizontally to the curve with the highest obtainable gear, then down to maximum speed. Usable rimpull will depend upon traction available and weight on drive wheels.

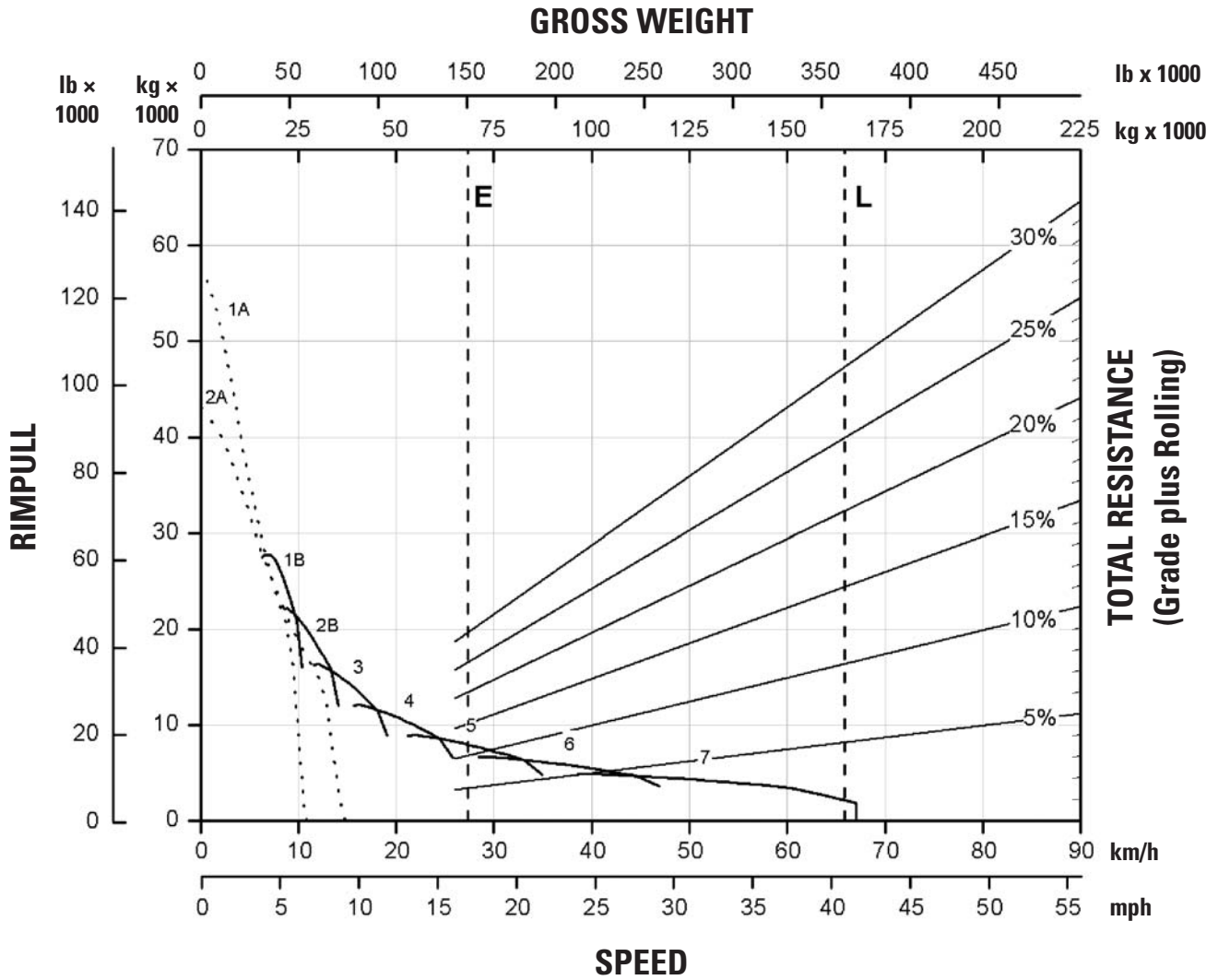

777G Off-Highway Truck Specifications

Retarding Performance (Tier 2 Equivalent)

To determine retarding performance: Add lengths of all downhill segments and, using this total, refer to proper retarding chart. Read from gross weight down to the percent effective grade. Effective grade equals actual % grade minus 1% for each 10 kg/t (20 lb/ton) of rolling resistance. From this weight-effective grade point, read horizontally to the curve with the highest obtainable gear, then down to maximum descent speed brakes can properly handle without exceeding cooling capacity. The following charts are based on these conditions: 32° C (90° F) ambient temperature, at sea level, with 24.00R35 (E4) tires.

NOTE: Select the proper gear to maintain engine rpm at the highest possible level, without overspeeding the engine. If cooling oil overheats, reduce ground speed to allow transmission to shift to the next lower speed range.

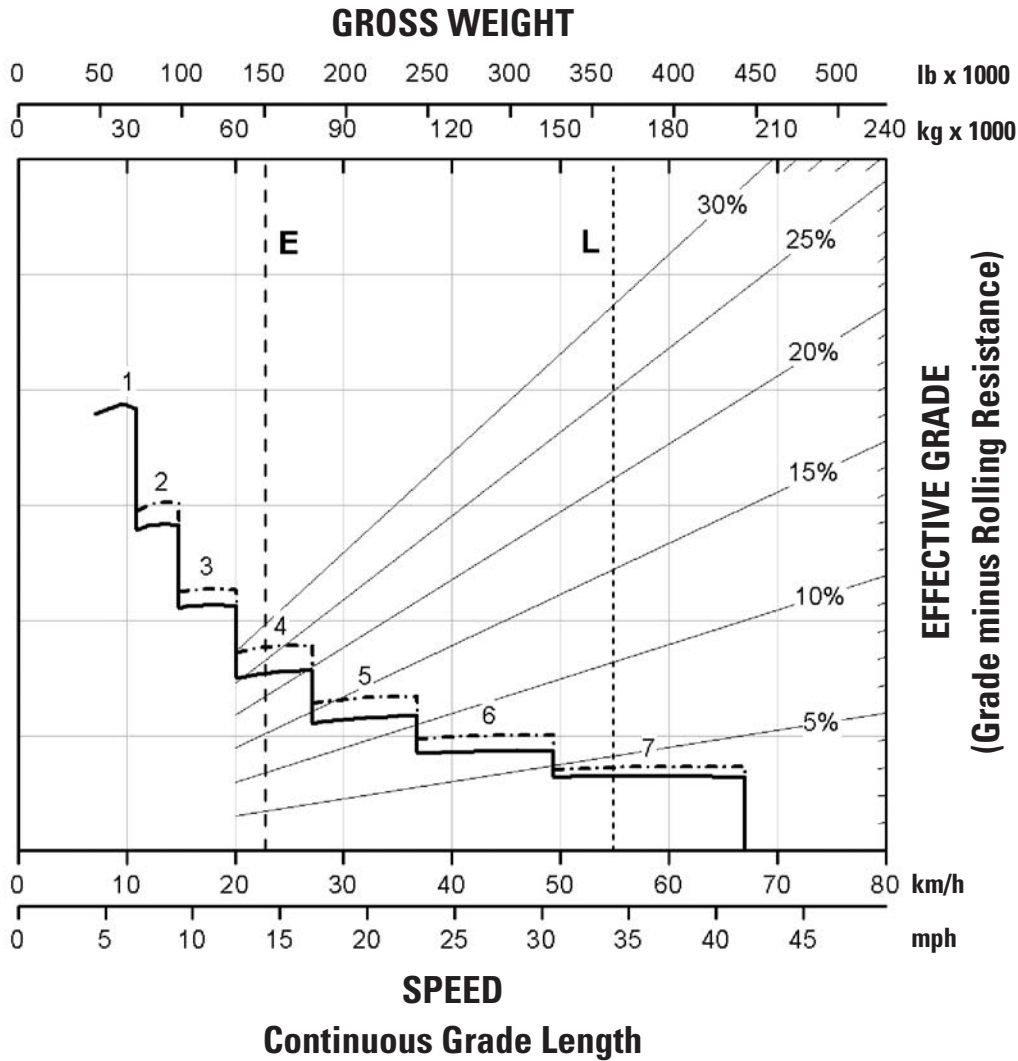

Retarding Performance (Tier 2 Equivalent)

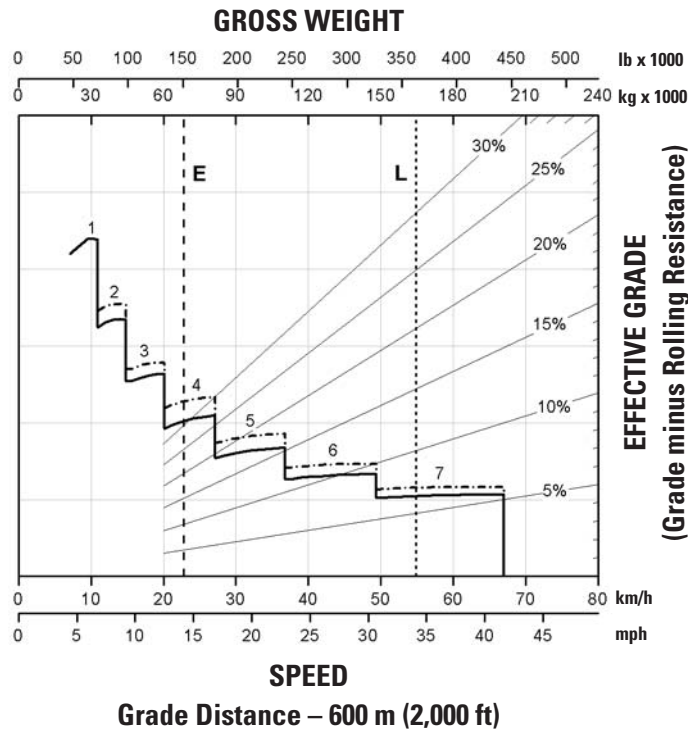
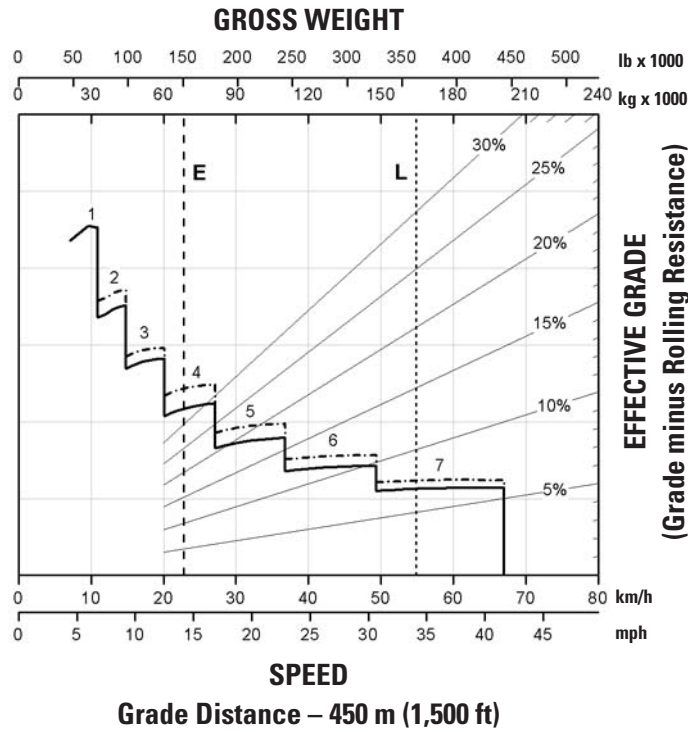

----- Engine Brake

777G Off-Highway Truck Specifications

Retarding Performance (Tier 2 Equivalent)

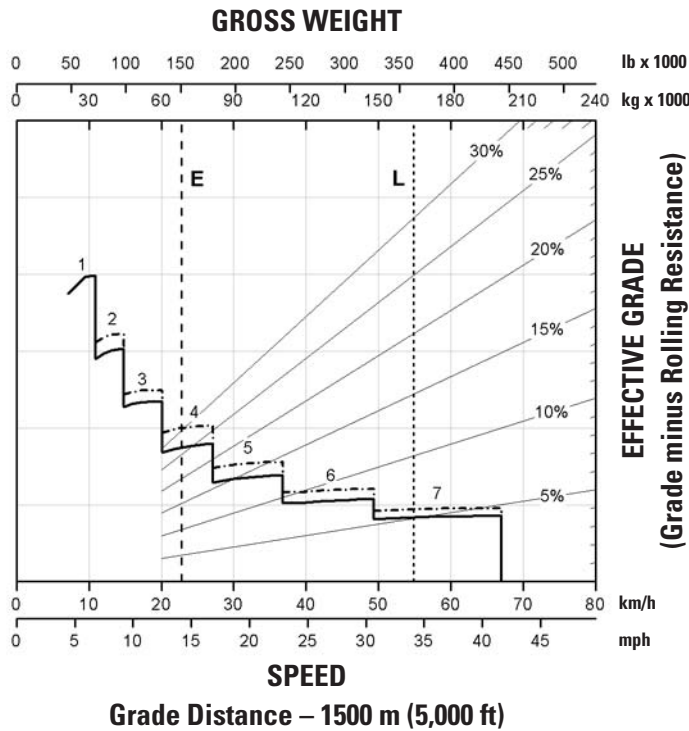
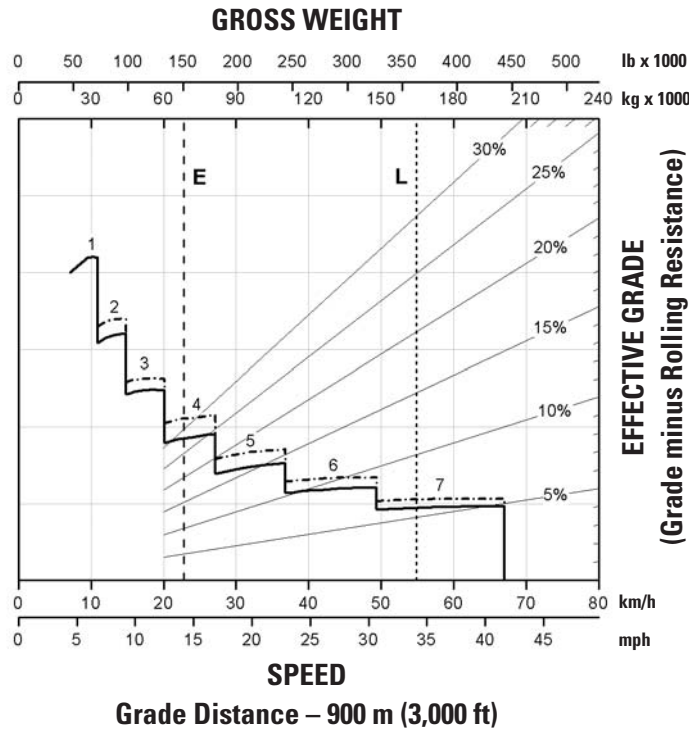

----- Engine Brake

Gradeability/Speed/Rimpull (Tier 2 Equivalent)

To determine gradeability performance: Read from gross weight down to the percent of total resistance. Total resistance equals actual percent grade plus 1% for each 10 kg/t (20 lb/ton) of rolling resistance. From this weight-resistance point, read horizontally to the curve with the highest obtainable gear, then down to maximum speed. Usable rimpull will depend upon traction available and weight on drive wheels.

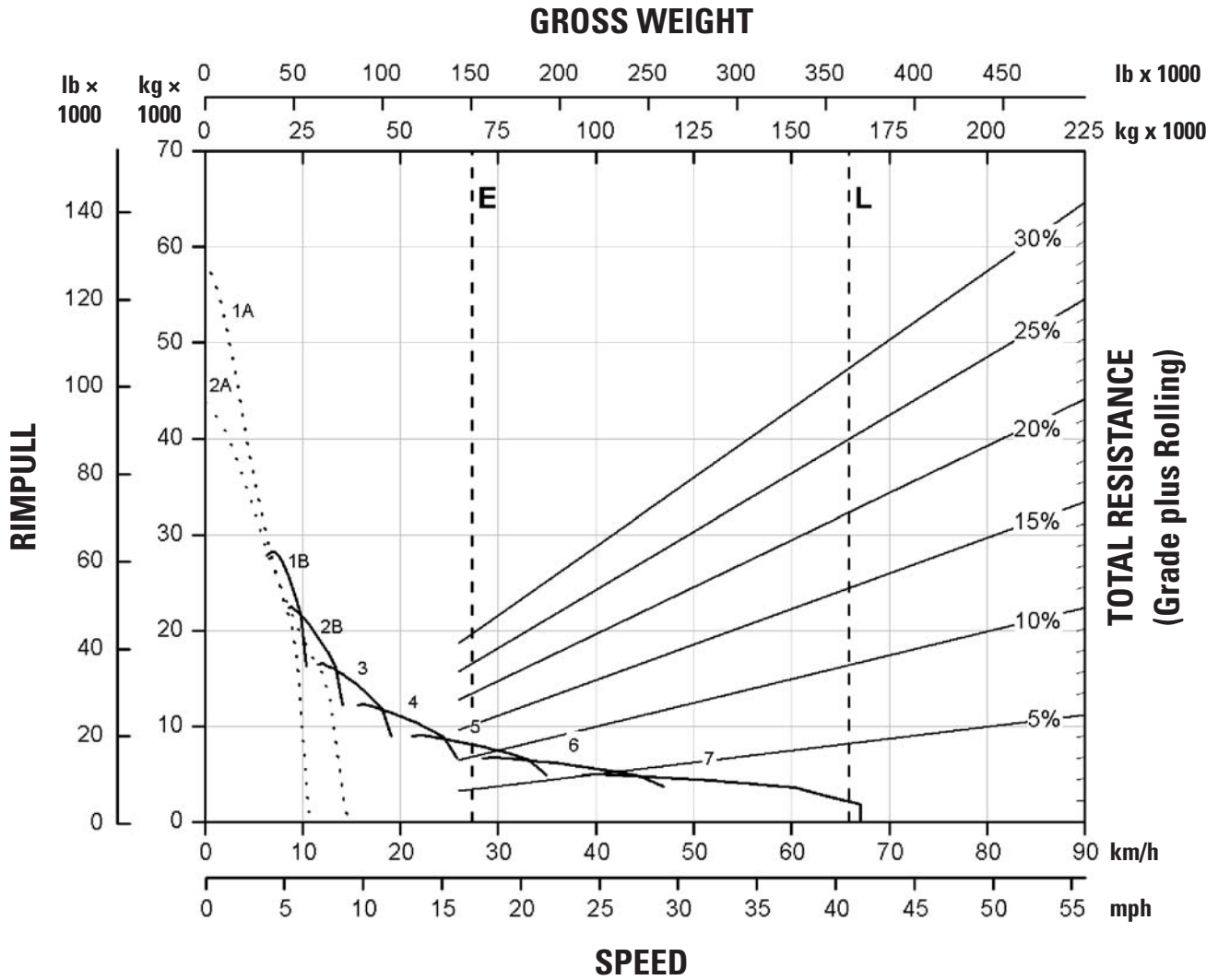

Standard Equipment

Standard equipment may vary. Consult your Cat dealer for details.

POWER TRAIN

- Autostall
- Engine idle shutdown
- Air-To-Air Aftercooler (ATAAC)
- Air cleaner with precleaner (2)
- Automatic cold mode idle control
- Electric priming pump
- Electric cold weather start (two starters and four batteries)
- Ether starting aid
- Exhaust, muffler
- Fuel filter/water separator
- Turbocharger (2)
- Braking system:
 - Brake wear indicator
 - Automatic Retarder Control (ARC) (utilizes oil-cooled, multiple disc brakes)
 - Brake release motor (towing)
 - Manual retarder (utilizes oil cooled, multiple disc brakes)
 - Oil-cooled, multiple disc (front/rear)
 - Parking
 - Secondary
 - Service
- Transmission
 - Auto neutral idle
 - APECS Software
 - ECPC
- Part Throttle Shifting
 - 7 speed automatic powershift with Torque Shift Management electronic clutch pressure control
 - Body up shift inhibitor
 - Directional shift management
 - Downshift inhibitor
 - Neutral start switch
 - Neutral coast inhibitor
 - Reverse shift inhibitor
 - Reverse neutralizer during dumping
 - Programmable top gear selection

SUSPENSION SYSTEMS

- Suspension, rear (EU Compliant)

ELECTRICAL

- Alarm, backup
- Alternator, 115 ampere
- Auxiliary jump start receptacle
- Batteries, maintenance-free, 12V (4), 190 amp-hour
- Electrical system, 25 AMP, 24V to 12V converter
- Lighting system
 - Backup light (halogen)
 - Directional signals/hazard warning, (front and rear LED)
 - Headlights, (halogen) with dimmer
 - Payload, indicator lights
 - Operator access courtesy lights
 - Side profile lights
 - Stop/tail lights (LED)
 - Service lights

OPERATOR ENVIRONMENT

- Air conditioning
- Ashtray and cigarette lighter
- Coat hook
- Cup holders (4)
- Diagnostic connection port, 24V
- Entertainment Radio Ready
 - 5 amp converter
 - Speakers
 - Antenna
 - Wiring harness
- Gauges/indicators
 - Brake oil temperature gauge
 - Coolant temperature gauge
 - Hour meter
 - Tachometer
 - Engine overspeed indicator
 - Fuel level
 - Speedometer with odometer
 - Transmission gear indicator
- Heater/defroster (11 070 kCal/43,930 BTU)
- Auto temp control
- Fluid level monitoring

- Hoist lever
- Horn, electric
- Light – dome
- Light – courtesy
- Load counter, automatic
- Advisor display
- VIMS
- TPMS
- Foot rest
- Mirrors – heated
- Power port, 24V and 12V (2)
- ROPS cab, insulated/sound suppressed
- Cat Comfort Series III
 - Full air suspension
 - Retractable 3 point seat belt with shoulder harness
- Steering wheel, padded, tilt and telescopic
- Storage compartment
- Sun visor
- Throttle lock
- Window, right side, hinged access/egress
- Electric left side window control
- Windshield wiper (intermittent) and washer
- Tinted, laminated glass

TECHNOLOGY PRODUCTS

- Product Link Ready (Level 1)
- TKPH/TMPH (Tons Kilometer Per Hour/ Tons Mile Per Hour)
- Object Detection (4 cameras, 4 radars)
- Adaptive economy mode

GUARDS

- Engine crankcase
- Driveline
- Fan and A/C

FLUIDS

- Extended Life Coolant to –35° C (–30° F)

Standard Equipment (cont'd)

Standard equipment may vary. Consult your Cat dealer for details.

OTHER STANDARD EQUIPMENT

- Body mounting group
- Body safety pin (secures body in up position)
- Body down indicator
- CD ROM parts book
- Center mounted rims
- Fuel tank (1136 L/300 gal)
- Ground level battery disconnect
- Ground level engine shutdown
- Ground level grease fittings
- Reservoirs (separate)
 - Brake/hoist
 - Steering
 - Transmission/torque converter
- Rims 19.5 × 49
- Rock ejectors
- Supplemental steering (automatic)
- Tie down eyes
- Tow hooks (front)/Tow pin (rear)
- Vandalism protection locks
- Wiggins fast fuel
- Traction Control System (new version)
- Attachment Zone

777G Optional Equipment

Optional Equipment

Optional equipment may vary. Consult your Cat dealer for details.

- Body heat
- Body liners
- Body side boards
- Cab precleaner
- Cat Engine Brake
- Clustered grease fittings
- Cold weather packages
- Extended Life Brakes
- Fluid fill service center
- HID lights
- Mirrors, convex
- Mirrors, heated
- Spare rim
- Visibility package (meets ISO 5006 requirements)
- Wheel chocks
- Work Area Vision System (WAVS)

For more complete information on Cat products, dealer services, and industry solutions, visit us on the web at www.cat.com

© 2013 Caterpillar Inc.
All rights reserved

Materials and specifications are subject to change without notice. Featured machines in photos may include additional equipment. See your Cat dealer for available options.

CAT, CATERPILLAR, SAFETY.CAT.COM, their respective logos, "Caterpillar Yellow" and the "Power Edge" trade dress, as well as corporate and product identity used herein, are trademarks of Caterpillar and may not be used without permission.

AEHQ6822-01 (02-2013)
Replaces AEHQ6822

