

M316D

Wheel Excavator



Engine

| | |
|-----------------------------------|----------------------------------|
| Engine Model | Cat® C6.6 with ACERT™ Technology |
| Net power (ISO 9249) at 1,800 rpm | 118 kW (160 hp) |

Weights

| | |
|------------------|---------------------|
| Operating Weight | 17 000 to 19 200 kg |
|------------------|---------------------|

Bucket Specifications

| | |
|-------------------|-----------------------------|
| Bucket Capacities | 0.38 to 1.26 m ³ |
|-------------------|-----------------------------|

Working Ranges

| | |
|-------------------------------|---------|
| Maximum Reach at Ground Level | 9380 mm |
| Maximum Digging Depth | 6070 mm |

Drive

| | |
|----------------------|---------|
| Maximum Travel Speed | 37 km/h |
|----------------------|---------|

Features

Engine

The EU Stage IIIA compliant C6.6 offers increased performance and reliability while reducing fuel consumption and sound levels.

Environmentally Responsible Design

Helping to protect our environment, the engine has low operator and spectator sound levels, longer filter change intervals and is more fuel-efficient.

Hydraulics

The state of the art load-sensing hydraulic system combined with a separate dedicated swing pump provides fast cycle times, increased lift capacity and high bucket and stick forces. This combination maximizes your productivity in any job.

Serviceability

For increased safety, all daily maintenance points are accessible from ground level. A centralized greasing system allows lubrication of critical points.

Operator Comfort

The totally redesigned operator station maximizes comfort while increasing safety. The available auto-weight adjusted air-suspension seat with heated and cooled ventilated cushions improves operator comfort. Safety is enhanced by the new color monitor and standard rear-mounted camera.

Undercarriage

Various undercarriage configuration with blade and outriggers are available to provide the best solution for you.

Contents

| | |
|---|----|
| Engine | 3 |
| Hydraulics | 4 |
| SmartBoom™..... | 5 |
| Environmentally Responsible Design | 5 |
| Operator Comfort | 6 |
| Undercarriage | 8 |
| Booms and Sticks | 9 |
| Work Tools..... | 10 |
| Serviceability and Complete Customer Support..... | 12 |
| Versatility..... | 14 |
| Specifications..... | 15 |
| Standard Equipment..... | 26 |
| Optional Equipment..... | 27 |



The D Series incorporates innovations for improved performance and versatility.

Increased lifting capacity, improved cycle times and ease of operation lead to increased productivity and lower operating costs.

Engine

Built for power, reliability, low maintenance, excellent fuel economy and low emissions.

Powerful Performance

The Cat® C6.6 engine with ACERT™ Technology introduces a series of evolutionary, incremental improvements that provide breakthrough engine performance. The building blocks of ACERT Technology are fuel delivery, air management and electronic control. ACERT Technology optimizes engine performance while meeting EU Stage IIIA engine emission regulations. The Cat C6.6 engine in the M316D delivers a maximum gross power of 124 kW at a rated speed of 1,800 rpm. This is 20% more horsepower as compared to the 3056E in the M316C.

Low Fuel Consumption

The C6.6 is electronically controlled and uses the new Cat Common Rail Fuel System and fuel pump. This combination provides outstanding fuel consumption during both production and travel. When the system recognizes roading application the engine will operate at the most efficient system operating point to save fuel without compromising road performance.

Low Noise, Low Vibration

The Cat C6.6 design improves operator comfort by reducing sound and vibration.

Cooling System

An electronically controlled, hydraulic motor drives a variable speed on-demand fan for engine coolant and hydraulic oil. The optimum fan speed is determined based on coolant and hydraulic oil temperature resulting in reduced fuel consumption and lower sound levels. The electronic engine control continuously compensates for the varying fan load, providing consistent net power, regardless of operating conditions.

One-Touch Low Idle Control

The two stage, one-touch Automatic Engine Speed Control reduces engine speed if no operation is performed, maximizing fuel efficiency and reducing sound levels.

Waste Handling Package

The Waste Handling Package has been specifically developed for Cat Wheel Excavators working in waste transfer stations or other extremely dusty applications. This option features the following:

- An automatic, hydraulic reversible fan that reverses airflow after a set interval, manually adjustable between 5 and 60 minutes with a switch located inside the cab.
- A special dense wire mesh cooling system hood further reduces radiator clogging.
- Two cyclone filters provide clean filtered air to the engine compartment, air cleaner, aftercooler and air conditioner condenser.



Hydraulics

Load-sensing hydraulic system provides fast cycle times, increased lift capacity and high bucket and stick forces to maximize your productivity in any job.



Dedicated Swing Pump

A dedicated variable displacement piston pump and fixed displacement piston motor power the swing mechanism. This closed hydraulic circuit maximizes swing performance without reducing power to the other hydraulic functions, resulting in smoother combined movements.

Heavy Lift Mode

This mode maximizes lifting performance by boosting the lifting capability of the excavator by 7%.

Adjustable Hydraulic Sensitivity

This function allows the operator to adjust the aggressiveness of the machine according to the application. For precision work, one of four different levels of aggressiveness can be preselected.

Proportional Auxiliary Hydraulics

Versatility of the hydraulic system can be expanded to utilize a wide variety of hydraulic work tools using multiple valve options.

- The Multi-Combined Valve is the core of the Tool Control System, allowing the operator to select up to ten preprogrammed work tools from the monitor. These preset hydraulic parameters support either one-way or two-way flow. The joystick sliding switches allow modulated control of the work tool.
- A dedicated Hammer circuit is the best option for tools that require one-way flow only, and do not require the flexibility provided by the Multi-Combined Valve.
- The Medium Pressure Function Valve provides proportional flow that is ideal for tilting buckets or rotating tools.
- A new feature for the D Series Wheel Excavators is the optional second High Pressure valve. In combination with the Multi-Combined Valve, it provides the possibility to operate the machine with work tools or in applications requiring a third auxiliary hydraulic function, such as a tilting/rotating work tool.

Stick Regeneration Circuit

The stick regeneration circuit increases efficiency and helps increase controllability for higher productivity and lower operating costs.

Quick Coupler

The machine can be optionally equipped with a dedicated hydraulic circuit to operate hydraulic quick couplers.

Hydraulic Snubbers

Caterpillar integrates its cylinder snubber technology into all Wheel Excavator boom and stick cylinders. These snubbers help cushion shocks, reduce sound and increase cylinder life.

SmartBoom™

Reduces stress and vibrations transmitted to the machine and provides a more comfortable environment.

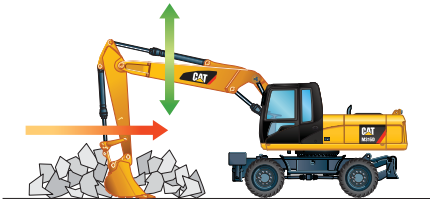

Rock Scraping

Scraping rock and finishing work is easy and fast. SmartBoom simplifies the task and allows the operator to concentrate on stick and bucket, while boom freely goes up and down without using pump flow.

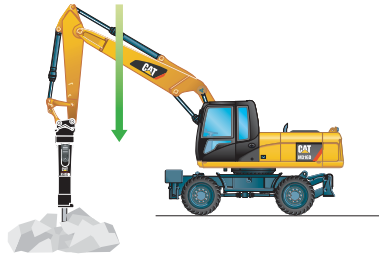

Hammer Work

The front parts automatically follow the hammer while penetrating the rock. Blank shots or excessive force on the hammer are avoided resulting in longer life for the hammer and the machine. Similar advantages with vibratory plate compactors.

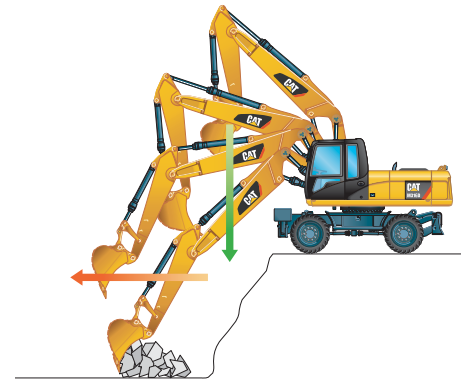

Truck Loading

Loading trucks from a bench is more productive and fuel efficient as the return cycle is reduced while the boom down function does not require pump flow.

Environmentally Responsible Design

The M316D helps build a better world and preserve the fragile environment.

Fuel Efficiency

The D Series Wheel Excavators are designed for outstanding performance with high fuel efficiency. This means more work done in a day, less fuel consumed and minimal impact on our environment.

Low Exhaust Emissions

The new Cat® C6.6 engine meets the new EU Stage IIIA emissions regulations while offering increased performance, reliability and reduced fuel consumption and sound levels.

Quiet Operation

Operator and spectator noise levels are extremely low as a result of the new variable speed fan and remote cooling system.

Biodegradable Hydraulic Oil

The optional biodegradable hydraulic oil (Cat BIO HYDO Advanced HEES™) is formulated to provide excellent

high-pressure and high temperature characteristics, and is fully compatible with all hydraulic components. Cat BIO HYDO Advanced HEES™ is fully decomposed by soil or water microorganisms, providing a more environmentally sound alternative to mineral-based oils.

Fewer Leaks and Spills

Lubricant fillers and drains are designed to minimize spills. Cat O-Ring Face Seals, Cat XT™ Hose and hydraulic cylinders are all designed to help prevent fluid leaks that can reduce the machine performance and cause harm to the environment.

Longer Service Intervals

Working closely with your Cat dealer can help extend service intervals for engine oil, hydraulic oil, axle oil and coolant. Meaning fewer required fluids and fewer disposal, all adding up to lower operating costs.

Operator Comfort

The interior layout maximizes operator space, provides exceptional comfort and reduces operator fatigue.



Interior Operator Station

Improved visibility and ergonomics are some of the many new features of the D Series Wheel Excavators. The operator station provides maximum space and is designed for simplicity and functionality. Frequently used switches are centralized and are situated on the right-hand switch console. The left-hand seat console controls dozer blade and/or outriggers, and is tiltable for easy access to the cab. The fully automatic climate control adjusts temperature and air flow for exceptional operator comfort. Other comfort features include a cigar lighter, ashtray, cup/can holder, magazine rack and integrated mobile phone holder.

Cab Construction

The exterior design uses thick steel tubing along the bottom perimeter of the cab, improving the resistance to fatigue and vibration. This design allows the falling object guards to be bolted directly to the cab. The cab shell is attached to the frame with rubber mounts that limit vibration and sound transmitted from the frame, substantially reducing interior noise levels.

Viewing Area

To maximize visibility, all glass is affixed directly to the cab, eliminating the use of window frames. Choice of fixed or easy-to-open split front windshield meet operator preference and application conditions.

- The 70/30 split front windshield stores the upper portion above the operator. The lower front windshield features a rounded design to maximize downward visibility and improves wiper coverage. Also features the one-touch action release system.
- The fixed front windshield comes with high impact resistant laminated glass.
- A large skylight provides superb upward visibility. The retractable sunscreen blocks direct sunlight.

Heated Mirrors

Another new feature is electrically heated mirrors, increasing safety and visibility in cold conditions.

Wipers

The parallel wiper system maximizes visibility in poor weather conditions. The wiper virtually covers the entire front windshield, cleaning the operator's immediate line of sight.

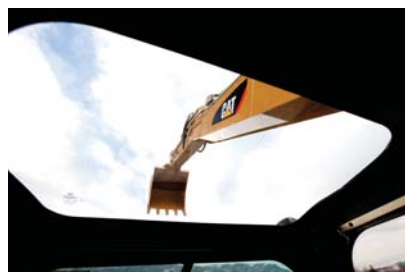

Monitor

The new compact color monitor displays information in local language that is easy to read and understand. Functions include:

- 2 times 5 programmable “Quick Access” buttons for one-touch selection of favorite functions.
- Filter and oil change warnings are displayed when the number of hours reaches the maintenance interval.
- Tool select function allows the operator to select up to 10 predefined hydraulic work tools.
- Adjustable braking characteristics enable the operator to select three levels of travel motor retarder aggressiveness when releasing the travel pedal.
- Provides a rear camera view that is activated through the monitor menu.



New Deluxe Seat

The new optional deluxe seat, equipped with an active seat climate system, improves operator comfort. Cooled air flows through the seat cushions to reduce body perspiration. On cold days, a two-step seat heater keeps the operator warm and comfortable. The fully adjustable seat with adjustable lumbar support automatically adjusts to the driver's weight providing a more relaxed and comfortable environment.



Lunch Box

A large storage compartment is located behind the operator's seat. The compartment provides sufficient room to store items such as a lunch box. A cover secures the contents during machine operation.



Foot Pedals

Two-way pedals for travel and auxiliary circuits provide increased floor space, reducing the need to change positions. The foot pedal for auxiliary high-pressure circuit can be locked in the off position and used as a footrest for greater operator comfort.

Cat Standard Rearview Camera

The rearview camera displays on the operator monitor. Together with the best in class visibility to the front, up, left and right, the rearview camera ensures the safe operation of the machine and fulfills the requirements of ISO 5006/EN474.

Field of Vision

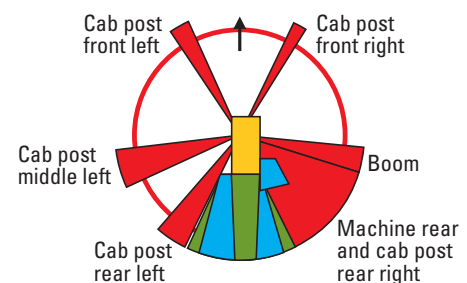

Legend:

Red: limitations due to cab post and/or boom

Blue: additional visibility due to mirrors

Green: additional visibility due to rearview camera



Undercarriage

Undercarriage and axle design provides maximum strength, flexibility and mobility on wheels.

Increased Travel Speed

The maximum travel speed for the M316D has been increased from 34 to 37 km/h, reducing travel time between sites and increasing productivity.

Heavy-Duty Axles and Stabilizers

The D Series undercarriage provides rigidity and long life. Effective hydraulic line routing, transmission protection and heavy-duty axles make the undercarriage perfect for wheel excavator applications. The front axle offers wide oscillating and steering angles. The transmission is mounted directly on the rear axle for protection and optimum ground clearance.

Advanced Disc Brake System

The disc brake system acts directly on the hub instead of the drive shaft to avoid planetary gear backlash. This solution minimizes the rocking effect associated with working free on wheels. The axle design lowers maintenance and lifetime costs. Oil change intervals are at 2,000 working hours, further reducing owning and operating costs.

Fenders

The optional fenders provide excellent coverage of the front and rear tires, protecting the machine from mud and dirt. Water cannot splash up on the windscreen or cooler. The fenders further protect the machine from stones and debris being thrown up by the tires, providing additional safety for the machine, other vehicles and personnel working close to the excavator.

Adjustable Travel Alarm

An adjustable travel alarm is available to warn people when the machine is moving. Three settings can be selected through the monitor:

- Auto mode – alarm will stop sounding immediately when the machine is no longer traveling, or has been sounding for an uninterrupted 10-second interval.
- Standard mode – alarm operates constantly during moving, with only manual cancellation.
- Off mode – travel alarm is disabled.

Booms and Sticks

Designed for maximum flexibility to keep production high on all jobs.

Design

Booms and sticks are welded, box section structures with thick, multiplate fabrications in high stress areas, for rugged performance and long service life.

Flexibility

The choice of three booms and four sticks provides the right balance of reach and digging forces for all applications.

Variable Adjustable (VA) Boom

The VA boom offers improved right side visibility and machine roading balance. When working in tight quarters or lifting heavy loads, the VA boom offers the best flexibility.

One-Piece Boom

The one-piece boom fits best for all standard applications such as truck loading and digging. A unique straight section in the curve of the side plate reduces stress flow and helps increase boom life.

Offset Boom

The large offset dimensions (left/right 2460/2760 mm) allow you to dig along walls, over obstacles, to grade while driving, and to dig under laid tubes without damaging them. The combination with a tiltable ditch cleaning bucket lets you operate a highly versatile system.

Sticks

Four different stick lengths are offered to match different application requirements:

- Short stick (2100 mm) for maximum breakout force and lifting capability.
- Medium stick (2400 mm) for greater crowd force and lift capacity.
- Long stick (2600 mm) for greater depth and reach requirements.
- Industrial stick (3100 mm) for use with free-swinging grapples in material handling and industrial applications.



Work Tools

A wide variety of Work Tools help optimize machine performance.

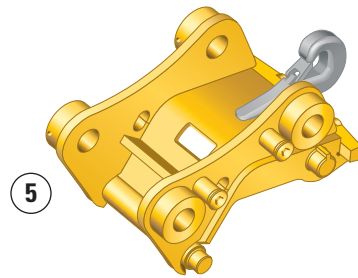
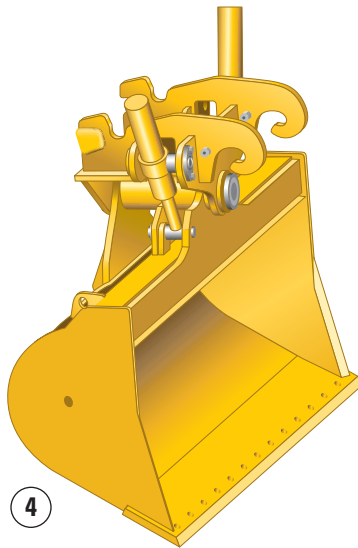
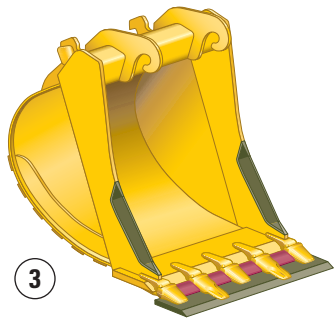
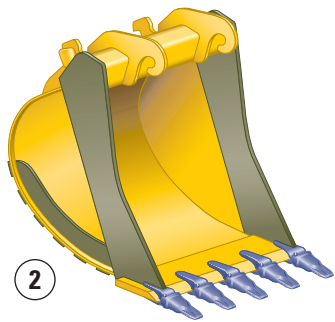
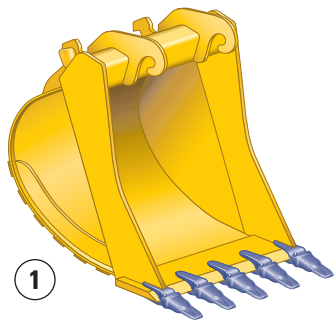

Work Tools

Cat work tools are designed to function as an integral part of your excavator and to provide the best possible performance in your particular application. All work tools are performance-matched to Cat machines.

Quick Couplers

Quick Couplers enable the operator to simply release one work tool and connect to another, making your hydraulic excavator highly versatile. Productivity also increases, as a carrier no longer needs to be idle between jobs. Caterpillar offers hydraulic and spindle quick coupler versions.

Buckets

Caterpillar offers a wide range of specialized buckets, each designed and tested to function as an integral part of your excavator. Buckets feature the new Cat K Series™ Ground Engaging Tools.

- 1 **Excavation (X)**
- 2 **Extreme Excavation (EX)**
- 3 **Excavation Leveling**
- 4 **Ditch Cleaning**
- 5 **Quick Coupler**

Purpose designed and built to Caterpillar's high durability standards.

Hammers

Cat hammer series deliver very high blow rates, increasing the productivity of your tool carriers in demolition and construction applications. Wide oil flow acceptance ranges make the Cat hammers suitable for a wide range of carriers and provide a system solution from one safe source.

Orange Peel Grapples

The Orange Peel Grapple is constructed of high-strength, wear-resistant steel, with a low and compact design that makes it ideal for dump clearance. There are several choices of tine and shell versions.

Multi-Grapples

The Multi-Grapple with unlimited left and right rotation is the ideal tool for stripping, sorting, handling and loading. The powerful closing force of the grab shells combined with fast opening/closing time ensures rapid cycle time which translates to more tons per hour.

Multi-Processors

Thanks to its single basic housing design, the Multi-Processor series of hydraulic demolition equipment makes it possible to use a range of jaw sets that can handle any demolition job. The Multi-Processor is the most versatile demolition tool on the market.

Vibratory Plate Compactors

Cat compactors are performance-matched to Cat machines, and integrate perfectly with the Cat hammer line – brackets and hydraulic kits are fully interchangeable between hammers and compactors.

Shears

Cat shears provide superior and effective scrap processing, and are highly productive in demolition environments. Shears are compatible with a matching Cat excavator, and bolt-on brackets are available for either stick or boom-mounted options.



Serviceability and Complete Customer Support

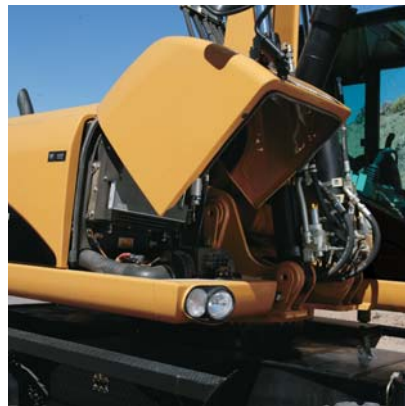

Ground Level Maintenance

Caterpillar designed its D Series Wheel Excavators with the operator and service technician in mind. Gull-wing doors, with pneumatically-assisted lift cylinders, effortlessly lift up to allow critical maintenance to be performed quickly and efficiently while maintaining operator safety.

Extended Service Intervals

The D Series Wheel Excavator service and maintenance intervals have been extended to reduce machine service time, increase machine availability and reduce operating costs. Using S·O·SSM Scheduled Oil Sampling analysis, hydraulic oil change intervals can be extended up to 6,000 hours.

Engine Oil

Cat engine oil is formulated to optimize engine life and performance. The specially formulated oil is more cost effective and increases engine oil change interval to 500 hours, providing industry leading performance and savings.

Air Filters

Cat air filters eliminate the use of service tools, reducing maintenance time. The air filter features a double-element construction with wall flow filtration in the main element and built-in mini-cyclone precleaners for superior cleaning efficiency. The air filters are constantly monitored for optimum performance. If airflow becomes restricted, a warning is displayed by the way of the in-cab monitor.

Capsule Filter

The hydraulic return filter, a capsule filter, prevents contaminants from entering the system when the hydraulic oil is changed.

Fuel Filters

Cat high efficiency fuel filters with a Stay-Clean ValveTM features a special media that removes more than 98% of particles, increasing fuel injector life. Both the primary and secondary fuel filters are located in the engine compartment and can be easily changed from ground level.

Water Separator

The D Series is equipped with a primary fuel filter with water separator located in the engine compartment. For ease of service, the water separator can be easily accessed from ground level.

Fuel Tank Drain

The durable, corrosion-free tank has a remote drain located at the bottom of the upper frame to remove water and sediment. The tank drain with hose connection allows simple, spill-free fluid draining.

Simplified and easy maintenance save you time and money. Cat dealer services help you operate longer with lower costs.

Front Compartment

The front compartment hood can be opened vertically, providing outstanding ground level access to the batteries, air-to-air aftercooler, air conditioner condenser and the air cleaner filter.

Swing-out Air Conditioner Condenser

The air conditioning condenser swings out horizontally to allow complete cleaning on both sides as well as excellent access to the air-to-air aftercooler.

Scheduled Oil Sampling

Caterpillar has specially developed S-O-SSM Oil Sampling Analysis to help ensure better performance, longer life and increased customer satisfaction. This thorough and reliable early warning system detects traces of metals, dirt and other contaminants in your engine, axle and hydraulic oil. It can predict potential trouble avoiding costly failures. Your Cat dealer can give you results and specific recommendations shortly after receiving your sample.

Engine Inspection

The engine can be accessed from both ground level and the upper structure. The longitudinal layout ensures that all daily inspection items can be accessed from ground level.

Anti-Skid Plates

They cover the top of the steps and upper structure to help prevent slipping during maintenance. The Anti-Skid plates reduce the accumulation of mud on the upper structure, improving the cleanliness and safety.

Easy to Clean Coolers

Flat fins on all coolers reduce clogging, making it easier to remove debris. The main cooling fan and air conditioner condenser are both hinged for easier cleaning.

Remote Greasing Blocks

For those hard to reach locations, greasing blocks have been provided to reduce maintenance time.

Handrails and Steps

Large handrails and steps assist the operator in climbing on and off the machine.

New LED Rear Lights

Standard Light Emitting Diode (LED) rear lights replace the standard lights, for increased visibility on the job site, higher durability and longer life.



Versatility

A wide variety of optional factory-installed attachments are available to enhance performance and improve job site management.



Tool Control

The integrated Tool Control system allows the operator to select up to 10 preset combinations. This eliminates the need to reset the hydraulic parameters each time a tool is changed. Individual flow and pressure can be programmed easily as well as one-way/two-way hydraulic functions. Each of the ten-programmed tools can even be given a specific name. The unique Cat proportional sliding switches and optional auxiliary pedal provide modulation to the tool to make precision work easy.

Joystick Steering

The unique joystick steering option enables an operator to reposition the machine while traveling in first gear by the use of the slider switch on the right joystick. This enables the operator to keep both hands on the joysticks while simultaneously moving the implements and traveling. The operator can do more precise work faster with increased safety around the machine.

Control Settings

There are 2 selectable control settings and one automatic travel setting. The operator can choose the best power setting for both engine and hydraulic power versus fuel efficiency.

- Economy Mode – used for lifting, pipe setting, grading, slope finishing and precise work while reducing fuel consumption.
- Power Mode – used for normal truck loading and digging applications, trenching or hammer use.
- Travel Mode – automatically set when the travel pedal is actuated. It provides maximum speed and drawbar pull.

Product Link

Product Link can assist with Fleet Management to keep track of hours, location, security and product health. The machine is prewired to accept Product Link systems to be installed in the field. Product Link is also available as a factory installed attachment.

Machine Security

An optional Machine Security System is available from the factory. This system controls who can operate the machine when, and utilizes specific keys to prevent unauthorized machine use.

Ride Control

New for the D Series, the ride control system improves operator comfort and allows the machine to travel faster over rough terrain with improved ride quality for the operator. The ride control system features accumulators acting as shock absorbers to dampen the front part motion. Ride control can be activated through a button located on the soft switch panel in the cab.

M316D Wheel Excavator Specifications

Engine

| | |
|-----------------------------|----------------------------------|
| Engine Model | Cat® C6.6 with ACERT™ Technology |
| Ratings | 1,800 rpm |
| Gross Power | 124 kW (169 hp) |
| Net Power | |
| ISO 9249 | 118 kW (160 hp) |
| 80/1269/EEC | 118 kW (160 hp) |
| Bore | 105 mm |
| Stroke | 127 mm |
| Displacement | 6.6 L |
| Cylinders | 6 |
| Maximum Torque at 1,400 rpm | 785 N·m |

- All engine horsepower (hp) are metric including front page.
- EU Stage IIIA compliant.
- Full engine net power up to 3000 m altitude.

Hydraulic System

| | |
|--------------------------|-----------|
| Tank Capacity | 135 L |
| System | 230 L |
| Maximum Pressure | |
| Implement Circuit | |
| Normal | 350 bar |
| Heavy Lift | 375 bar |
| Travel Circuit | 350 bar |
| Auxiliary Circuit | |
| High Pressure | 350 bar |
| Medium Pressure | 185 bar |
| Swing Mechanism | 370 bar |
| Maximum Flow | |
| Implement/Travel Circuit | 250 L/min |
| Auxiliary Circuit | |
| High Pressure | 250 L/min |
| Medium Pressure | 50 L/min |
| Swing Mechanism | 80 L/min |

Weights

| | |
|------------------------------|-----------|
| VA Boom* | |
| Rear Dozer Only | 16 650 kg |
| Rear Dozer, Front Outriggers | 17 650 kg |
| Front and Rear Outriggers | 17 850 kg |
| One-Piece Boom* | |
| Rear Dozer Only | 16 150 kg |
| Rear Dozer, Front Outriggers | 17 150 kg |
| Front and Rear Outriggers | 17 350 kg |
| Offset Boom* | |
| Rear Dozer Only | 17 150 kg |
| Rear Dozer, Front Outriggers | 18 150 kg |
| Front and Rear Outriggers | 18 350 kg |
| Sticks | |
| Short (2100 mm) | 470 kg |
| Medium (2400 mm) | 514 kg |
| Long (2600 mm) | 530 kg |
| Industrial (3100 mm) | 450 kg |
| Dozer Blade | 740 kg |
| Outriggers | 1030 kg |
| Counterweight | |
| Standard | 3700 kg |
| Optional | 4100 kg |

- Machine weight with medium stick, 4100 kg counterweight, with operator and full fuel tank, without work tool. Weight varies depending on configuration.

Transmission

| | |
|----------------------|---------|
| Forward/Reverse | |
| 1st Gear | 8 km/h |
| 2nd Gear | 37 km/h |
| Creeper Speed | |
| 1st Gear | 3 km/h |
| 2nd Gear | 13 km/h |
| Drawbar Pull | 97 kN |
| Maximum Gradeability | 63% |

Swing Mechanism

| | |
|--------------|----------|
| Swing Speed | 10.5 rpm |
| Swing Torque | 40 kN·m |

Tires

| | |
|-----------------------------------|--|
| Standard | |
| • 10.00-20 (dual pneumatic) | |
| Optional | |
| • 11.00-20 (dual pneumatic) | |
| • 18 R 19.5 XF (single pneumatic) | |
| • 10.00-20 (dual solid rubber) | |

Undercarriage

| | |
|------------------------|---------|
| Ground Clearance | 370 mm |
| Maximum Steering Angle | 35° |
| Oscillation Axle Angle | ± 9° |
| Minimum Turning Radius | |
| Standard Axle | |
| Outside of Tire | 6400 mm |
| End of VA Boom | 7000 mm |
| End of One-Piece Boom | 8300 mm |
| Wide Axle | |
| Outside of Tire | 6500 mm |
| End of VA Boom | 7100 mm |
| End of One-Piece Boom | 8500 mm |

Service Refill Capacities

| | |
|------------------------------------|--------|
| Fuel Tank | 310 L |
| Cooling | 36 L |
| Engine Crankcase | 15 L |
| Rear Axle Housing (differential) | 14 L |
| Front Steering Axle (differential) | 10.5 L |
| Final Drive | 2.5 L |
| Powershift Transmission | 2.5 L |

Sound Levels

Exterior Sound

- The labeled spectator sound power level measured according to the test procedures and conditions specified in 2000/14/EC is 103 dB(A).

Cab/ROPS/FOGS

- Cat cab with integrated Roll Over Protective Structure (ROPS) meets ISO 12117-2:2008 criteria.
- Cab with Falling Object Guard Structure (FOGS) meets ISO 10262.

M316D Wheel Excavator Specifications

Dimensions

All dimensions are approximate.

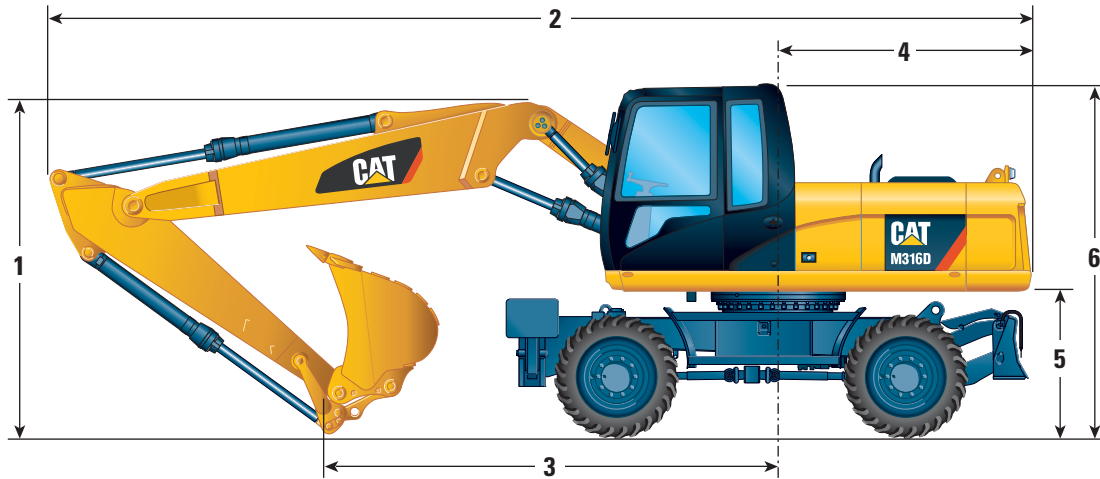

| | mm | VA Boom | | | | One-Piece Boom | | | | Offset Boom | |
|------------------------------|----|---------|------|------|-------|----------------|------|------|-------|-------------|------|
| | | 2100 | 2400 | 2600 | *3100 | 2100 | 2400 | 2600 | *3100 | 2100 | 2400 |
| Stick Length | mm | 2100 | 2400 | 2600 | *3100 | 2100 | 2400 | 2600 | *3100 | 2100 | 2400 |
| 1 Shipping Height | mm | 3170 | 3170 | 3170 | 3330 | 3170 | 3170 | 3170 | 3330 | 3170 | 3170 |
| 2 Shipping Length | mm | 8550 | 8550 | 8540 | 8510 | 8390 | 8400 | 8400 | 8405 | 8550 | 8540 |
| 3 Support Point | mm | 3910 | 3650 | 3550 | 3630 | 3560 | 3270 | 3150 | 3230 | 4020 | 3780 |
| 4 Tail Swing Radius | mm | | 2280 | | | | 2280 | | | 2280 | |
| 5 Counterweight Clearance | mm | | 1280 | | | | 1280 | | | 1280 | |
| 6 Cab Height | mm | | 3170 | | | | 3170 | | | 3170 | |
| With 1200 mm Fixed Cab Riser | mm | | 4370 | | | | 4370 | | | 4370 | |
| Overall Machine Width | mm | | 2550 | | | | 2550 | | | 2550 | |
| Wide Gauge Axle | mm | | 2750 | | | | 2750 | | | 2750 | |

* Industrial stick

** Maximum tire clearance with outrigger fully down

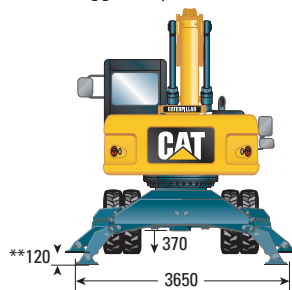
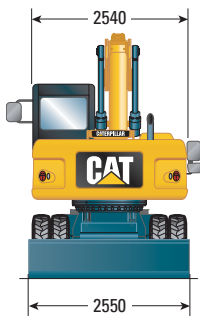

Roading position with 2400 mm stick

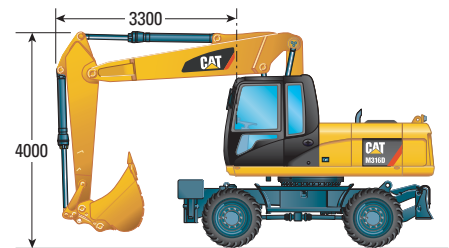

Undercarriage with dozer only

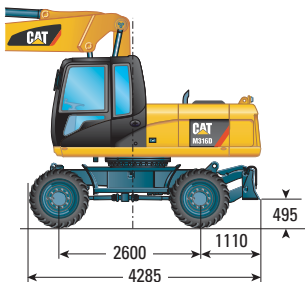

Undercarriage with 2 sets of outriggers

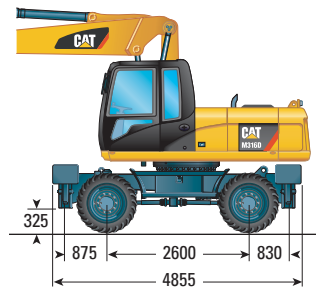

Undercarriage with 1 set of outriggers and dozer

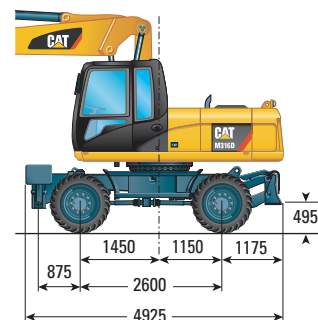

Working Ranges

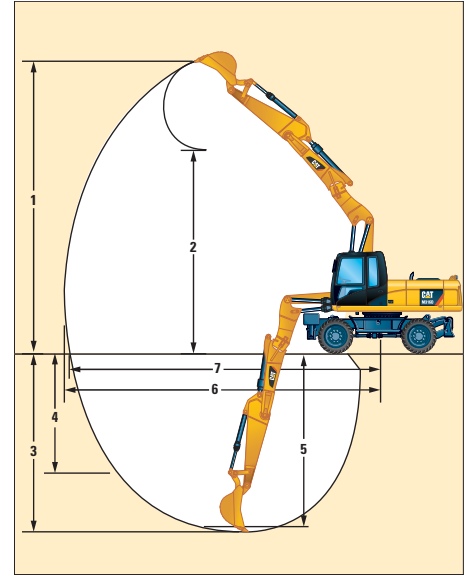
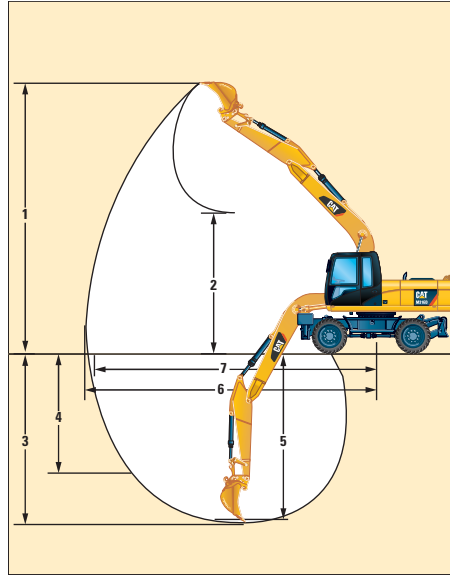
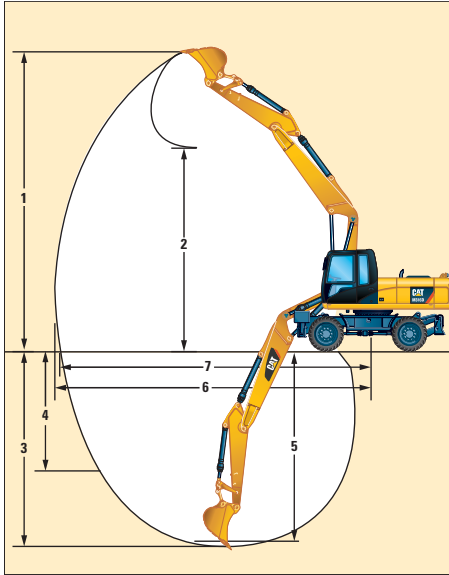

| | mm | VA Boom | | | | One-Piece Boom | | | | Offset Boom | |
|--|----|---------|--------|--------|-------|----------------|------|------|-------|-------------|--------|
| | | 2100 | 2400 | 2600 | *3100 | 2100 | 2400 | 2600 | *3100 | 2100 | 2400 |
| Stick Length | mm | | | | | | | | | | |
| 1 Digging Height | mm | 10 060 | 10 250 | 10 400 | 8970 | 9000 | 9090 | 9210 | 7720 | 9960 | 10 150 |
| 2 Dump Height | mm | 6970 | 7160 | 7320 | 3980 | 6020 | 6130 | 6250 | 3200 | 7150 | 7340 |
| 3 Digging Depth | mm | 5570 | 5870 | 6070 | 5030 | 5370 | 5670 | 5870 | 4820 | 5450 | 5750 |
| 4 Vertical Wall Digging Depth | mm | 3700 | 3900 | 4070 | – | 3490 | 3630 | 3800 | – | 4100 | 4320 |
| 5 Depth 2.5 m Straight Clean-Up | mm | 5350 | 5670 | 5880 | – | 5150 | 5470 | 5680 | – | 5200 | 5520 |
| 6 Reach | mm | 9100 | 9360 | 9560 | 8370 | 8900 | 9160 | 9350 | 8130 | 8970 | 9240 |
| 7 Reach at Ground Level | mm | 8910 | 9190 | 9380 | 8170 | 8710 | 8970 | 9170 | 7920 | 8780 | 9060 |
| Bucket Forces (ISO 6015) | kN | 101 | 101 | 101 | – | 101 | 101 | 101 | – | 101 | 101 |
| Stick Forces (ISO 6015) | kN | 81 | 74 | 71 | – | 81 | 74 | 71 | – | 81 | 74 |

* Industrial stick has no bucket linkage. All dimensions refer to sticknose.

Values 1-7 are calculated with bucket and quick coupler with a tip radius of 1552 mm.

Breakout force values are calculated with heavy lift on (no quick coupler) and a tip radius of 1405 mm.

M316D Wheel Excavator Specifications

Bucket Specifications

Contact your Cat dealer for special bucket requirements.

| Pin-On Buckets | | | | | Variable Adjustable Boom 5200 mm | | | | | | | | | | | | One-Piece Boom 5050 mm | | | | | | | | | | | |
|-------------------------------|-------|---------|----------------|----------|-------------------------------------|---------------|-----------------------------|------------------|----------------|---------------|-----------------------------|------------------|----------------|---------------|-----------------------------|------------------|---------------------------|---------------|-----------------------------|------------------|----------------|---------------|-----------------------------|------------------|----------------|---------------|-----------------------------|------------------|
| Stick Length | | | | | 2100 mm | | | | 2400 mm | | | | 2600 mm | | | | 2100 mm | | | | 2400 mm | | | | 2600 mm | | | |
| | Width | Weight* | Capacity (ISO) | Adapters | Free on wheels | Dozer lowered | 1 set of stabilizer lowered | Fully stabilized | Free on wheels | Dozer lowered | 1 set of stabilizer lowered | Fully stabilized | Free on wheels | Dozer lowered | 1 set of stabilizer lowered | Fully stabilized | Free on wheels | Dozer lowered | 1 set of stabilizer lowered | Fully stabilized | Free on wheels | Dozer lowered | 1 set of stabilizer lowered | Fully stabilized | Free on wheels | Dozer lowered | 1 set of stabilizer lowered | Fully stabilized |
| | mm | kg | m ³ | | | | | | | | | | | | | | | | | | | | | | | | | |
| Excavation | 600 | 459 | 0.38 | 3 | | | | | | | | | | | | | | | | | | | | | | | | |
| | 750 | 495 | 0.52 | 3 | | | | | | | | | | | | | | | | | | | | | | | | |
| | 900 | 557 | 0.65 | 4 | | | | | | | | | | | | | | | | | | | | | | | | |
| | 1000 | 591 | 0.75 | 4 | | | | | | | | | | | | | | | | | | | | | | | | |
| | 1100 | 622 | 0.84 | 4 | | | | | | | | | | | | | | | | | | | | | | | | |
| | 1200 | 668 | 0.94 | 5 | | | | | | | | | | | | | | | | | | | | | | | | |
| | 1300 | 699 | 1.03 | 5 | | | | | | | | | | | | | | | | | | | | | | | | |
| | 1400 | 731 | 1.13 | 5 | | | | | | | | | | | | | | | | | | | | | | | | |
| Extreme Excavation | 1200 | 702 | 0.94 | 5 | | | | | | | | | | | | | | | | | | | | | | | | |
| | 1300 | 735 | 1.03 | 5 | | | | | | | | | | | | | | | | | | | | | | | | |
| Excavation (leveling) | 600 | 485 | 0.41 | 3 | | | | | | | | | | | | | | | | | | | | | | | | |
| | 750 | 529 | 0.56 | 3 | | | | | | | | | | | | | | | | | | | | | | | | |
| | 800 | 547 | 0.61 | 4 | | | | | | | | | | | | | | | | | | | | | | | | |
| | 900 | 596 | 0.70 | 4 | | | | | | | | | | | | | | | | | | | | | | | | |
| | 1000 | 636 | 0.82 | 4 | | | | | | | | | | | | | | | | | | | | | | | | |
| | 1100 | 672 | 0.92 | 4 | | | | | | | | | | | | | | | | | | | | | | | | |
| | 1200 | 725 | 1.04 | 5 | | | | | | | | | | | | | | | | | | | | | | | | |
| | 1300 | 762 | 1.14 | 5 | | | | | | | | | | | | | | | | | | | | | | | | |
| | 1400 | 798 | 1.26 | 5 | | | | | | | | | | | | | | | | | | | | | | | | |
| Extreme Excavation (leveling) | 1200 | 757 | 1.04 | 5 | | | | | | | | | | | | | | | | | | | | | | | | |
| Ditch Cleaning | 1800 | 545 | 0.90 | | | | | | | | | | | | | | | | | | | | | | | | | |
| | 2000 | 590 | 1.00 | | | | | | | | | | | | | | | | | | | | | | | | | |
| Tilttable Ditch Cleaning | 1800 | 875 | 0.75 | | | | | | | | | | | | | | | | | | | | | | | | | |
| | 2000 | 910 | 0.84 | | | | | | | | | | | | | | | | | | | | | | | | | |

*Bucket weight includes Ground Engaging Tools

Maximum material density 1800 kg/m³

Maximum material density 1500 kg/m³

Maximum material density 1200 kg/m³

Not recommended

Bucket Specifications

Contact your Cat dealer for special bucket requirements.

| CW Quick Coupler Buckets | | | | | Variable Adjustable Boom 5200 mm | | | | | | | | | | | | One-Piece Boom 5050 mm | | | | | | | | | | | | |
|-------------------------------|-------|---------|----------------|----------|-------------------------------------|---------------|-----------------------------|------------------|----------------|---------------|-----------------------------|------------------|----------------|---------------|-----------------------------|------------------|---------------------------|---------------|-----------------------------|------------------|----------------|---------------|-----------------------------|------------------|----------------|---------------|-----------------------------|------------------|--|
| | | | | | 2100 mm | | | | 2400 mm | | | | 2600 mm | | | | 2100 mm | | | | 2400 mm | | | | 2600 mm | | | | |
| Stick Length | Width | Weight* | Capacity (ISO) | Adapters | Free on wheels | Dozer lowered | 1 set of stabilizer lowered | Fully stabilized | Free on wheels | Dozer lowered | 1 set of stabilizer lowered | Fully stabilized | Free on wheels | Dozer lowered | 1 set of stabilizer lowered | Fully stabilized | Free on wheels | Dozer lowered | 1 set of stabilizer lowered | Fully stabilized | Free on wheels | Dozer lowered | 1 set of stabilizer lowered | Fully stabilized | Free on wheels | Dozer lowered | 1 set of stabilizer lowered | Fully stabilized | |
| | | | | | mm | kg | m ³ | | | | | | | | | | | | | | | | | | | | | | |
| Excavation | 600 | 468 | 0.38 | 3 | | | | | | | | | | | | | | | | | | | | | | | | | |
| | 750 | 504 | 0.52 | 3 | | | | | | | | | | | | | | | | | | | | | | | | | |
| | 900 | 534 | 0.65 | 4 | | | | | | | | | | | | | | | | | | | | | | | | | |
| | 1000 | 568 | 0.75 | 4 | | | | | | | | | | | | | | | | | | | | | | | | | |
| | 1100 | 600 | 0.84 | 4 | | | | | | | | | | | | | | | | | | | | | | | | | |
| | 1200 | 645 | 0.94 | 5 | | | | | | | | | | | | | | | | | | | | | | | | | |
| | 1300 | 676 | 1.03 | 5 | | | | | | | | | | | | | | | | | | | | | | | | | |
| | 1400 | 708 | 1.13 | 5 | | | | | | | | | | | | | | | | | | | | | | | | | |
| Extreme Excavation | 1200 | 679 | 0.94 | 5 | | | | | | | | | | | | | | | | | | | | | | | | | |
| | 1300 | 712 | 1.03 | 5 | | | | | | | | | | | | | | | | | | | | | | | | | |
| Excavation (leveling) | 600 | 498 | 0.41 | 3 | | | | | | | | | | | | | | | | | | | | | | | | | |
| | 750 | 547 | 0.56 | 3 | | | | | | | | | | | | | | | | | | | | | | | | | |
| | 800 | 526 | 0.61 | 4 | | | | | | | | | | | | | | | | | | | | | | | | | |
| | 900 | 575 | 0.70 | 4 | | | | | | | | | | | | | | | | | | | | | | | | | |
| | 1000 | 614 | 0.82 | 4 | | | | | | | | | | | | | | | | | | | | | | | | | |
| | 1100 | 651 | 0.92 | 4 | | | | | | | | | | | | | | | | | | | | | | | | | |
| | 1200 | 704 | 1.04 | 5 | | | | | | | | | | | | | | | | | | | | | | | | | |
| | 1300 | 741 | 1.14 | 5 | | | | | | | | | | | | | | | | | | | | | | | | | |
| Extreme Excavation (leveling) | 1400 | 777 | 1.26 | 5 | | | | | | | | | | | | | | | | | | | | | | | | | |
| | 600 | 523 | 0.41 | 3 | | | | | | | | | | | | | | | | | | | | | | | | | |
| | 800 | 555 | 0.61 | 4 | | | | | | | | | | | | | | | | | | | | | | | | | |
| | 1000 | 644 | 0.82 | 4 | | | | | | | | | | | | | | | | | | | | | | | | | |
| Ditch Cleaning | 1200 | 736 | 1.04 | 5 | | | | | | | | | | | | | | | | | | | | | | | | | |
| | 1800 | 510 | 0.90 | | | | | | | | | | | | | | | | | | | | | | | | | | |
| Tiltable Ditch Cleaning | 2000 | 555 | 1.00 | | | | | | | | | | | | | | | | | | | | | | | | | | |
| | 1800 | 835 | 0.75 | | | | | | | | | | | | | | | | | | | | | | | | | | |
| | 2000 | 870 | 0.84 | | | | | | | | | | | | | | | | | | | | | | | | | | |

*Bucket weight includes Ground Engaging Tools

Maximum material density 1800 kg/m³

Maximum material density 1500 kg/m³

Maximum material density 1200 kg/m³

Not recommended

M316D Wheel Excavator Specifications

Work Tools Matching Guide

When choosing between various work tool models that can be installed onto the same machine configuration, consider work tool application, productivity requirements, and durability. Refer to work tool specifications for application recommendations and productivity information.

| Without Quick Coupler | | | Variable Adjustable Boom 5200 mm | | | | | | | | | | | | One-Piece Boom 5050 mm | | | | | | | | | | | | Offset Boom 5200 mm | | | | | |
|---|-------------------|------------|-------------------------------------|------|------|------|------|------|------|------|------|------|------|------|---------------------------|------|------|------|------|------|------|------|------|------|------|------|------------------------|------|------|------|------|------|
| | | | (1) | | | | (2) | | | | (3) | | | | (1) | | | | (2) | | | | (3) | | | | (1) | | (2) | | (3) | |
| | | | 2100 | 2400 | 2600 | 3100 | 2100 | 2400 | 2600 | 3100 | 2100 | 2400 | 2600 | 3100 | 2100 | 2400 | 2600 | 3100 | 2100 | 2400 | 2600 | 3100 | 2100 | 2400 | 2600 | 3100 | 2100 | 2400 | 2100 | 2400 | 2100 | 2400 |
| Stick Length (mm) | | | | | | | | | | | | | | | | | | | | | | | | | | | | | | | | |
| Hammers | H100, H100 S | | | | | | | | | | | | | | | | | | | | | | | | | | | | | | | |
| | H115 S, H120C S | | | | | | | | | | | | | | | | | | | | | | | | | | | | | | | |
| Multiprocessors | MP15 | CC, CR | | | | | | | | | | | | | | | | | | | | | | | | | | | | | | |
| | MP15 | PP | | | | | | | | | | | | | | | | | | | | | | | | | | | | | | |
| | MP15 | PS | | | | | | | | | | | | | | | | | | | | | | | | | | | | | | |
| | MP15 | S | | | | | | | | | | | | | | | | | | | | | | | | | | | | | | |
| Hydraulic Shears (* boom mounted) | S320B | | | | | | | | | | | | | | | | | | | | | | | | | | | | | | | |
| | S320B* | | | | | | | | | | | | | | | | | | | | | | | | | | | | | | | |
| | S325B* | | | | | | | | | | | | | | | | | | | | | | | | | | | | | | | |
| Multi-Grapples | G310B | D, R | | | | | | | | | | | | | | | | | | | | | | | | | | | | | | |
| | G315B | D | | | | | | | | | | | | | | | | | | | | | | | | | | | | | | |
| | | R | | | | | | | | | | | | | | | | | | | | | | | | | | | | | | |
| Compactor | CVP75 | | | | | | | | | | | | | | | | | | | | | | | | | | | | | | | |
| Orange Peel Grapples | GSH15B 5 tines | 400 | | | | | | | | | | | | | | | | | | | | | | | | | | | | | | |
| | | 500 | | | | | | | | | | | | | | | | | | | | | | | | | | | | | | |
| | | 600 | | | | | | | | | | | | | | | | | | | | | | | | | | | | | | |
| | | 800 | | | | | | | | | | | | | | | | | | | | | | | | | | | | | | |
| | GSH15B 4 tines | 400 | | | | | | | | | | | | | | | | | | | | | | | | | | | | | | |
| | | 500 | | | | | | | | | | | | | | | | | | | | | | | | | | | | | | |
| | | 600 | | | | | | | | | | | | | | | | | | | | | | | | | | | | | | |
| | | 800 | | | | | | | | | | | | | | | | | | | | | | | | | | | | | | |
| Crusher | P315 | | | | | | | | | | | | | | | | | | | | | | | | | | | | | | | |
| Pulverizer | P215 | | | | | | | | | | | | | | | | | | | | | | | | | | | | | | | |
| With Quick Coupler (CW-20, CW-20S) | | | (1) Dozer lowered | | | | | | | | | | | | | | | | | | | | | | | | | | | | | |
| | | | (2) 2 sets of stabilizers lowered | | | | | | | | | | | | | | | | | | | | | | | | | | | | | |
| | | | (3) Dozer and stabilizer lowered | | | | | | | | | | | | | | | | | | | | | | | | | | | | | |
| Hammers | H100, H100 S | | | | | | | | | | | | | | | | | | | | | | | | | | | | | | | |
| | H115 S, H120C S | | | | | | | | | | | | | | | | | | | | | | | | | | | | | | | |
| Multiprocessors | MP15 | CC, CR, PS | | | | | | | | | | | | | | | | | | | | | | | | | | | | | | |
| | MP15 | S | | | | | | | | | | | | | | | | | | | | | | | | | | | | | | |
| Multi-Grapples | G310B | D, R | | | | | | | | | | | | | | | | | | | | | | | | | | | | | | |
| | G315B | D, R | | | | | | | | | | | | | | | | | | | | | | | | | | | | | | |
| Compactor | CVP75 | | | | | | | | | | | | | | | | | | | | | | | | | | | | | | | |
| Crusher | P315 | | | | | | | | | | | | | | | | | | | | | | | | | | | | | | | |
| Pulverizer | P215 | | | | | | | | | | | | | | | | | | | | | | | | | | | | | | | |

360° Working Range
 Over the front only

Maximum material density 3000 kg/m³
 Maximum material density 1800 kg/m³
 Maximum material density 1200 kg/m³

Lift Capacities – Variable Adjustable Boom (5200 mm)

All values are in kg, without bucket and without QC, with counterweight (4100 kg), heavy lift on.

| Short Stick 2100 mm | Load at maximum reach (sticknose/bucket pin) | Load over front | Load over rear | Load over side | Load point height | 3.0 m | | | 4.5 m | | | 6.0 m | | | 7.5 m | | | m | | | |
|------------------------|--|-----------------|----------------|----------------|-------------------|-------|-------|-------|--|---|--|-------|---|---------------------------------------|-------|---|--------------------------------------|--|---|--|------|
| | | | | | | Stick | Stick | Stick | Stick | Stick | Stick | Stick | Stick | Stick | Stick | Stick | Stick | | Stick | Stick | |
| | | | | | | | | | | | | | | | | | | | | | |
| | Undercarriage configuration | | | | | | | | | | | | | | | | | | | | |
| 6.0 m | Rear dozer up Rear dozer down Dozer and stabilizer down 2 sets of stabilizers down Wide axle rear dozer up | | | | | | | | *6250 5300 4600 | 5300 *6250 *6250 *6250 5300 | 4600 5250 *6250 *6250 5050 | 4700 | 3300 *5050 *5050 *5050 3300 | 2900 3300 4900 *5050 3150 | | | | *3900 *3900 *3900 *3900 3150 | 3100 *3900 *3900 *3900 3150 | 2750 3100 *3900 *3900 2000 | 6.18 |
| 4.5 m | Rear dozer up Rear dozer down Dozer and stabilizer down 2 sets of stabilizers down Wide axle rear dozer up | | | | | | | | *6650 5100 4400 | 5100 *6650 *6650 *6650 5100 | 4400 5050 *6650 *6650 4850 | 4650 | 3250 *5100 *5100 *5100 3250 | 2850 3250 4850 *5100 3150 | | | | 3600 *3650 *3650 *3650 2500 | 2500 *3650 *3650 *3650 2400 | 2000 2500 *3650 *3650 2400 | 7.01 |
| 3.0 m | Rear dozer up Rear dozer down Dozer and stabilizer down 2 sets of stabilizers down Wide axle rear dozer up | | | | | | | | 6900 *7650 *7650 *7650 4750 | 4700 4700 *7650 *7650 4500 | 4050 4700 7300 *7650 4500 | 4500 | 3100 *5450 *5450 *5450 3150 | 2700 3150 4700 *5450 3000 | | | | 3250 *3600 *3600 *3600 2250 | 2250 *3600 *3600 *3600 2150 | 1950 2250 3400 *3600 2150 | 7.44 |
| 1.5 m | Rear dozer up Rear dozer down Dozer and stabilizer down 2 sets of stabilizers down Wide axle rear dozer up | | | | | | | | 6600 *8800 *8800 *8800 4450 | 4400 4400 *8800 *8800 4200 | 3800 4400 6950 8250 4200 | 4350 | 3000 *5950 *5950 *5950 3000 | 2600 3000 4550 5350 2850 | 3150 | 2200 *4300 *4300 *4300 2100 | 1900 2200 3300 3850 2100 | 3150 *3750 *3750 *3750 2150 | 1900 2150 3300 *3750 2050 | 7.54 | |
| 0.0 m | Rear dozer up Rear dozer down Dozer and stabilizer down 2 sets of stabilizers down Wide axle rear dozer up | | | | | | | | 6450 *8550 *8550 *8550 4300 | 3650 4250 6800 8100 4050 | 3650 4250 6800 8100 4050 | 4250 | 2900 *6300 *6300 *6300 2900 | 2500 2900 4450 5250 2750 | | | | 3250 *4100 *4100 *4100 2250 | 2200 *4100 *4100 *4100 2150 | 1950 2250 3400 3950 2150 | 7.32 |
| -1.5 m | Rear dozer up Rear dozer down Dozer and stabilizer down 2 sets of stabilizers down Wide axle rear dozer up | *7200 | *7200 | 6650 | 6450 | 4300 | 3650 | 4250 | 2900 | 2500 | 2900 | 2500 | | | | | | 3650 *4300 *4300 *4300 2500 | 2500 *4300 *4300 *4300 2400 | 2150 2500 3800 *4300 2400 | 6.76 |
| -3.0 m | Rear dozer up Rear dozer down Dozer and stabilizer down 2 sets of stabilizers down Wide axle rear dozer up | | | | | | | | *5300 *5300 *5300 *5300 4400 | 4400 4350 *5300 *5300 4150 | 3750 4350 *5300 *5300 4150 | | | | | | | | | | |

| Medium Stick 2400 mm | Load at maximum reach (sticknose/bucket pin) | Load over front | Load over rear | Load over side | Load point height | 3.0 m | | | 4.5 m | | | 6.0 m | | | 7.5 m | | | m | | | |
|-------------------------|--|-----------------|----------------|----------------|-------------------|-------|-------|-------|--|---|--|-------|---|--|-------|---|--------------------------------------|--|---|--|------|
| | | | | | | Stick | Stick | Stick | Stick | Stick | Stick | Stick | Stick | Stick | Stick | Stick | Stick | | Stick | | |
| | | | | | | | | | | | | | | | | | | | | | |
| | Undercarriage configuration | | | | | | | | | | | | | | | | | | | | |
| 6.0 m | Rear dozer up Rear dozer down Dozer and stabilizer down 2 sets of stabilizers down Wide axle rear dozer up | | | | | | | | *5450 5350 4650 | 5350 *5450 *5450 *5450 5100 | 4650 5350 *5450 *5450 3200 | 4750 | 3350 *4900 *4900 *4900 3200 | 2950 3350 *4900 *4900 3200 | | | | *3300 *3300 *3300 *3300 2900 | 2900 *3300 *3300 *3300 2900 | 2550 2900 *3300 *3300 2750 | 6.51 |
| 4.5 m | Rear dozer up Rear dozer down Dozer and stabilizer down 2 sets of stabilizers down Wide axle rear dozer up | | | | | | | | *6450 5150 4450 | 5100 *6450 *6450 *6450 5150 | 4450 5100 *6450 *6450 4900 | 4650 | 3300 *5000 *5000 *5000 3300 | 2850 3300 4900 *5000 3150 | | | | *3100 *3100 *3100 *3100 2350 | 2350 *3100 *3100 *3100 2250 | 2050 2350 *3100 *3100 2250 | 7.30 |
| 3.0 m | Rear dozer up Rear dozer down Dozer and stabilizer down 2 sets of stabilizers down Wide axle rear dozer up | | | | | | | | 6950 *7350 *7350 *7350 4800 | 4750 4750 *7350 *7350 4550 | 4100 4750 *7350 *7350 4550 | 4500 | 3150 *5300 *5300 *5300 3150 | 2750 3150 4700 *5300 3000 | 3200 | 2200 *4300 *4300 *4300 2250 | 1950 2250 3350 3900 2150 | 3050 *3100 *3100 *3100 2150 | 2100 *3100 *3100 *3100 2050 | 1850 2150 *3100 *3100 2050 | 7.71 |
| 1.5 m | Rear dozer up Rear dozer down Dozer and stabilizer down 2 sets of stabilizers down Wide axle rear dozer up | | | | | | | | 6600 *8700 *8700 *8700 4450 | 4450 4400 *8700 *8700 4200 | 3800 4400 6950 8300 4200 | 4350 | 3000 *5800 *5800 *5800 3000 | 2600 3000 4550 5300 2850 | 3150 | 2150 *4500 *4500 *4500 2150 | 1900 2150 3300 3850 2100 | 2950 *3250 *3250 *3250 2050 | 2050 *3250 *3250 *3250 1950 | 1750 2050 3100 *3250 1950 | 7.81 |
| 0.0 m | Rear dozer up Rear dozer down Dozer and stabilizer down 2 sets of stabilizers down Wide axle rear dozer up | | | | | | | | 6400 *8650 *8650 *8650 4250 | 4250 4250 *8650 *8650 4050 | 3650 4250 6800 8100 4050 | 4250 | 2900 *6350 *6350 *6350 2900 | 2500 2900 4450 5200 2750 | 3100 | 2150 *4650 *4650 *4650 2150 | 1850 2150 3250 3800 2050 | 3050 *3550 *3550 *3550 2100 | 2100 *3550 *3550 *3550 2000 | 1800 2100 3200 *3550 2000 | 7.60 |
| -1.5 m | Rear dozer up Rear dozer down Dozer and stabilizer down 2 sets of stabilizers down Wide axle rear dozer up | *7150 | *7150 | 6550 | 6400 | 4250 | 3600 | 4200 | 2850 | 2450 | 2850 | 2450 | | | | | | 3400 *4150 *4150 *4150 2300 | 2300 *4150 *4150 *4150 2200 | 2000 2300 3550 4150 2200 | 7.05 |
| -3.0 m | Rear dozer up Rear dozer down Dozer and stabilizer down 2 sets of stabilizers down Wide axle rear dozer up | | | | | | | | *5850 *5850 *5850 *5850 4300 | 4300 4300 *5850 *5850 4100 | 3700 4300 *5850 *5850 4100 | | | | | | | | | | |

*Limited by hydraulic rather than tipping load.

Lift capacity ratings are based on ISO 10567:2007, they do not exceed 87% of hydraulic lifting capacity or 75% of tipping load. The load point is the center line of the bucket pivot mounting pin on the stick. The oscillating axle must be locked. Lifting capacities are based on the machine standing on a firm uniform supporting surface and the Variable Boom Cylinder adjusted to the maximum length. For lifting capacity including bucket and/or quick coupler, the respective weight has to be subtracted from above values. The use of a work tool attachment point to handle/lift objects, could affect the machine lift performance.

Always refer to the appropriate Operation and Maintenance Manual for specific product information.

M316D Wheel Excavator Specifications

Lift Capacities – Variable Adjustable Boom (5200 mm)

All values are in kg, without bucket and without QC, with counterweight (4100 kg), heavy lift on.

| | | Load at maximum reach (sticknose/bucket pin) | Load over front | Load over rear | Load over side | Load point height | | | | | | | | | | | | | |
|-----------------------|--|--|-----------------|----------------|----------------|-------------------|------|-------|------|------|-------|------|------|-------|------|------|-------|------|------|
| Long Stick 2600 mm | Undercarriage configuration | 3.0 m | | | 4.5 m | | | 6.0 m | | | 7.5 m | | | m | | | | | |
| | | | | | | | | | | | | | | | | | | | |
| 6.0 m | Rear dozer up Rear dozer down Dozer and stabilizer down 2 sets of stabilizers down Wide axle rear dozer up | | | | *4950 | *4950 | 4700 | 4750 | 3400 | 2950 | | | | *3000 | 2750 | 2400 | 2750 | 2400 | 6.74 |
| 4.5 m | Rear dozer up Rear dozer down Dozer and stabilizer down 2 sets of stabilizers down Wide axle rear dozer up | | | | *5850 | 5200 | 4500 | 4700 | 3300 | 2900 | *2900 | 2250 | 2000 | *2850 | 2250 | 2000 | 2250 | 2000 | 7.51 |
| 3.0 m | Rear dozer up Rear dozer down Dozer and stabilizer down 2 sets of stabilizers down Wide axle rear dozer up | | | | 7000 | 4800 | 4150 | 4500 | 3150 | 2750 | 3200 | 2250 | 1950 | *2850 | 2050 | 1800 | 2050 | 1800 | 7.91 |
| 1.5 m | Rear dozer up Rear dozer down Dozer and stabilizer down 2 sets of stabilizers down Wide axle rear dozer up | | | | 6650 | 4450 | 3850 | 4350 | 3000 | 2600 | 3150 | 2150 | 1900 | 2850 | 1950 | 1700 | 1950 | 1700 | 8.00 |
| 0.0 m | Rear dozer up Rear dozer down Dozer and stabilizer down 2 sets of stabilizers down Wide axle rear dozer up | | | | 6450 | 4250 | 3650 | 4250 | 2900 | 2500 | 3100 | 2100 | 1850 | 2950 | 2000 | 1750 | 2000 | 1750 | 7.80 |
| -1.5 m | Rear dozer up Rear dozer down Dozer and stabilizer down 2 sets of stabilizers down Wide axle rear dozer up | *6900 | *6900 | 6550 | 6400 | 4250 | 3600 | 4200 | 2850 | 2450 | | | | 3250 | 2200 | 1900 | 2200 | 1900 | 7.27 |
| -3.0 m | Rear dozer up Rear dozer down Dozer and stabilizer down 2 sets of stabilizers down Wide axle rear dozer up | | | | *6150 | 4300 | 3650 | *4250 | 2900 | 2500 | | | | *3600 | 2700 | 2350 | *3600 | 2700 | 6.33 |

| | | Load at maximum reach (sticknose/bucket pin) | Load over front | Load over rear | Load over side | Load point height | | | | | | | | | | | | | |
|-----------------------------|--|--|-----------------|----------------|----------------|-------------------|------|-------|------|------|-------|------|------|-------|------|------|-------|------|------|
| Industrial Stick 3100 mm | Undercarriage configuration | 3.0 m | | | 4.5 m | | | 6.0 m | | | 7.5 m | | | m | | | | | |
| | | | | | | | | | | | | | | | | | | | |
| 6.0 m | Rear dozer up Rear dozer down Dozer and stabilizer down 2 sets of stabilizers down Wide axle rear dozer up | | | | | | | *4650 | 3650 | 3250 | | | | *3250 | 2750 | 2450 | 2750 | 2450 | 7.17 |
| 4.5 m | Rear dozer up Rear dozer down Dozer and stabilizer down 2 sets of stabilizers down Wide axle rear dozer up | | | | *5050 | *5050 | 4850 | 5000 | 3600 | 3200 | 3550 | 2550 | 2300 | *3150 | 2350 | 2100 | *3150 | 2350 | 7.89 |
| 3.0 m | Rear dozer up Rear dozer down Dozer and stabilizer down 2 sets of stabilizers down Wide axle rear dozer up | | | | *7050 | 5200 | 4550 | 4800 | 3450 | 3050 | 3500 | 2500 | 2200 | 3000 | 2150 | 1900 | *3200 | 2150 | 8.27 |
| 1.5 m | Rear dozer up Rear dozer down Dozer and stabilizer down 2 sets of stabilizers down Wide axle rear dozer up | | | | 7050 | 4850 | 4200 | 4650 | 3300 | 2900 | 3400 | 2450 | 2150 | 2950 | 2100 | 1850 | *3350 | 2100 | 8.36 |
| 0.0 m | Rear dozer up Rear dozer down Dozer and stabilizer down 2 sets of stabilizers down Wide axle rear dozer up | | | | 6800 | 4600 | 4000 | 4500 | 3150 | 2750 | 3350 | 2350 | 2100 | 3000 | 2100 | 1900 | *3700 | 2150 | 8.17 |
| -1.5 m | Rear dozer up Rear dozer down Dozer and stabilizer down 2 sets of stabilizers down Wide axle rear dozer up | *7350 | *7350 | 6850 | 6700 | 4550 | 3900 | 4450 | 3100 | 2700 | 3350 | 2350 | 2050 | 3250 | 2300 | 2000 | *4350 | 2300 | 7.66 |
| -3.0 m | Rear dozer up Rear dozer down Dozer and stabilizer down 2 sets of stabilizers down Wide axle rear dozer up | *9800 | 8400 | 6950 | 6700 | 4550 | 3900 | 4450 | 3100 | 2700 | | | | 3800 | 2700 | 2350 | *4150 | 2700 | 6.79 |

*Limited by hydraulic rather than tipping load.

Lift capacity ratings are based on ISO 10567:2007, they do not exceed 87% of hydraulic lifting capacity or 75% of tipping load. The load point is the center line of the bucket pivot mounting pin on the stick. The oscillating axle must be locked. Lifting capacities are based on the machine standing on a firm uniform supporting surface and the Variable Boom Cylinder adjusted to the maximum length. For lifting capacity including bucket and/or quick coupler, the respective weight has to be subtracted from above values. The use of a work tool attachment point to handle/lift objects, could affect the machine lift performance.

Always refer to the appropriate Operation and Maintenance Manual for specific product information.

Lift Capacities – One-Piece Boom (5050 mm)

All values are in kg, without bucket and without QC, with counterweight (4100 kg), heavy lift on.

| Short Stick 2100 mm | Undercarriage configuration | 3.0 m | | | 4.5 m | | | 6.0 m | | | 7.5 m | | | Load point height | | | m | |
|------------------------|--|--|-----------------|----------------|----------------|-----------------|----------------|----------------|-----------------|----------------|----------------|-----------------|----------------|-------------------|-------------------|-------|------|------|
| | | Load at maximum reach (sticknose/bucket pin) | Load over front | Load over rear | Load over side | Load over front | Load over rear | Load over side | Load over front | Load over rear | Load over side | Load over front | Load over rear | Load over side | Load point height | | | |
| 6.0 m | Rear dozer up Rear dozer down Dozer and stabilizer down 2 sets of stabilizers down Wide axle rear dozer up | | | | | | | | | | | | | | *3850 | 3350 | 2950 | 5.93 |
| 4.5 m | Rear dozer up Rear dozer down Dozer and stabilizer down 2 sets of stabilizers down Wide axle rear dozer up | | | | *6650 | 5100 | 4450 | 4650 | 3300 | 2900 | | | | | *3600 | 2650 | 2350 | 6.80 |
| 3.0 m | Rear dozer up Rear dozer down Dozer and stabilizer down 2 sets of stabilizers down Wide axle rear dozer up | | | | 6950 | 4800 | 4150 | 4500 | 3150 | 2750 | | | | | 3400 | 2400 | 2100 | 7.24 |
| 1.5 m | Rear dozer up Rear dozer down Dozer and stabilizer down 2 sets of stabilizers down Wide axle rear dozer up | | | | *8850 | *8850 | 7000 | *6450 | *6450 | 4600 | | | | | *3800 | *3800 | 3450 | 7.34 |
| 0.0 m | Rear dozer up Rear dozer down Dozer and stabilizer down 2 sets of stabilizers down Wide axle rear dozer up | | | | 6500 | 4350 | 3750 | 4300 | 2950 | 2600 | | | | | 3400 | 2350 | 2050 | 7.11 |
| -1.5 m | Rear dozer up Rear dozer down Dozer and stabilizer down 2 sets of stabilizers down Wide axle rear dozer up | *8850 | 8200 | 6800 | 6500 | 4350 | 3750 | 4250 | 2950 | 2550 | | | | | 3800 | 2650 | 2300 | 6.53 |
| -3.0 m | Rear dozer up Rear dozer down Dozer and stabilizer down 2 sets of stabilizers down Wide axle rear dozer up | *7850 | *7850 | 6950 | *5950 | 4450 | 3850 | | | | | | | | *4300 | 3450 | 3000 | 5.46 |

| Medium Stick 2400 mm | Undercarriage configuration | 3.0 m | | | 4.5 m | | | 6.0 m | | | 7.5 m | | | Load point height | | | m | |
|-------------------------|--|--|-----------------|----------------|----------------|-----------------|----------------|----------------|-----------------|----------------|----------------|-----------------|----------------|-------------------|-------------------|------|------|------|
| | | Load at maximum reach (sticknose/bucket pin) | Load over front | Load over rear | Load over side | Load over front | Load over rear | Load over side | Load over front | Load over rear | Load over side | Load over front | Load over rear | Load over side | Load point height | | | |
| 6.0 m | Rear dozer up Rear dozer down Dozer and stabilizer down 2 sets of stabilizers down Wide axle rear dozer up | | | | | | | *4300 | 3350 | 2950 | | | | | *3250 | 3100 | 2750 | 6.25 |
| 4.5 m | Rear dozer up Rear dozer down Dozer and stabilizer down 2 sets of stabilizers down Wide axle rear dozer up | | | | *6300 | 5100 | 4500 | 4650 | 3300 | 2900 | | | | | *3100 | 2500 | 2200 | 7.08 |
| 3.0 m | Rear dozer up Rear dozer down Dozer and stabilizer down 2 sets of stabilizers down Wide axle rear dozer up | | | | 7000 | 4800 | 4200 | 4500 | 3150 | 2800 | | | | | *3100 | 2250 | 2000 | 7.50 |
| 1.5 m | Rear dozer up Rear dozer down Dozer and stabilizer down 2 sets of stabilizers down Wide axle rear dozer up | | | | 6650 | 4500 | 3900 | 4350 | 3050 | 2650 | 3150 | 2200 | 1950 | | 3100 | 2150 | 1900 | 7.60 |
| 0.0 m | Rear dozer up Rear dozer down Dozer and stabilizer down 2 sets of stabilizers down Wide axle rear dozer up | | | | 6500 | 4350 | 3750 | 4250 | 2950 | 2550 | | | | | 3200 | 2200 | 1950 | 7.38 |
| -1.5 m | Rear dozer up Rear dozer down Dozer and stabilizer down 2 sets of stabilizers down Wide axle rear dozer up | *8550 | 8100 | 6700 | 6450 | 4300 | 3700 | 4250 | 2900 | 2500 | | | | | 3550 | 2450 | 2150 | 6.82 |
| -3.0 m | Rear dozer up Rear dozer down Dozer and stabilizer down 2 sets of stabilizers down Wide axle rear dozer up | *8750 | 8250 | 6850 | *6500 | 4400 | 3750 | | | | | | | | *4400 | 3100 | 2700 | 5.81 |

*Limited by hydraulic rather than tipping load.

Lift capacity ratings are based on ISO 10567:2007, they do not exceed 87% of hydraulic lifting capacity or 75% of tipping load. The load point is the center line of the bucket pivot mounting pin on the stick. The oscillating axle must be locked. Lifting capacities are based on the machine standing on a firm uniform supporting surface. For lifting capacity including bucket and/or quick coupler, the respective weight has to be subtracted from above values. The use of a work tool attachment point to handle/lift objects, could affect the machine lift performance.

Always refer to the appropriate Operation and Maintenance Manual for specific product information.

M316D Wheel Excavator Specifications

Lift Capacities – One-Piece Boom (5050 mm)

All values are in kg, without bucket and without QC, with counterweight (4100 kg), heavy lift on.

| Long Stick 2600 mm | Undercarriage configuration | 3.0 m | | | 4.5 m | | | 6.0 m | | | 7.5 m | | | Load point height | | | m |
|-----------------------|--|--|-----------------|----------------|----------------|--|-----------------|----------------|----------------|--|-----------------|----------------|----------------|--|-----------------|----------------|------|
| | | Load at maximum reach (sticknose/bucket pin) | Load over front | Load over rear | Load over side | Load at maximum reach (sticknose/bucket pin) | Load over front | Load over rear | Load over side | Load at maximum reach (sticknose/bucket pin) | Load over front | Load over rear | Load over side | Load at maximum reach (sticknose/bucket pin) | Load over front | Load over rear | |
| 6.0 m | Rear dozer up Rear dozer down Dozer and stabilizer down 2 sets of stabilizers down Wide axle rear dozer up | | | | | | | *4400 | 3350 | 2950 | | | | *2950 | 2950 | 2600 | 6.49 |
| 4.5 m | Rear dozer up Rear dozer down Dozer and stabilizer down 2 sets of stabilizers down Wide axle rear dozer up | | | | | | | 4650 | 3300 | 2900 | | | | *2800 | 2400 | 2100 | 7.28 |
| 3.0 m | Rear dozer up Rear dozer down Dozer and stabilizer down 2 sets of stabilizers down Wide axle rear dozer up | | | | 7050 | 4850 | 4200 | 4550 | 3200 | 2800 | 3250 | 2250 | 2000 | *2850 | 2150 | 1900 | 7.69 |
| 1.5 m | Rear dozer up Rear dozer down Dozer and stabilizer down 2 sets of stabilizers down Wide axle rear dozer up | | | | 6700 | 4550 | 3900 | 4400 | 3050 | 2650 | 3150 | 2200 | 1950 | *3000 | 2100 | 1850 | 7.79 |
| 0.0 m | Rear dozer up Rear dozer down Dozer and stabilizer down 2 sets of stabilizers down Wide axle rear dozer up | *4450 | *4450 | *4450 | 6500 | 4350 | 3750 | 4250 | 2950 | 2550 | 3150 | 2150 | 1900 | 3100 | 2150 | 1800 | 7.58 |
| -1.5 m | Rear dozer up Rear dozer down Dozer and stabilizer down 2 sets of stabilizers down Wide axle rear dozer up | *8200 | 8050 | 6700 | 6450 | 4300 | 3700 | 4250 | 2900 | 2500 | | | | 3400 | 2350 | 2050 | 7.03 |
| -3.0 m | Rear dozer up Rear dozer down Dozer and stabilizer down 2 sets of stabilizers down Wide axle rear dozer up | *9300 | 8200 | 6800 | 6500 | 4350 | 3750 | 4300 | 2950 | 2600 | | | | 4250 | 2900 | 2550 | 6.06 |

| Industrial Stick 3100 mm | Undercarriage configuration | 3.0 m | | | 4.5 m | | | 6.0 m | | | 7.5 m | | | Load point height | | | m |
|-----------------------------|--|--|-----------------|----------------|----------------|--|-----------------|----------------|----------------|--|-----------------|----------------|----------------|--|-----------------|----------------|------|
| | | Load at maximum reach (sticknose/bucket pin) | Load over front | Load over rear | Load over side | Load at maximum reach (sticknose/bucket pin) | Load over front | Load over rear | Load over side | Load at maximum reach (sticknose/bucket pin) | Load over front | Load over rear | Load over side | Load at maximum reach (sticknose/bucket pin) | Load over front | Load over rear | |
| 6.0 m | Rear dozer up Rear dozer down Dozer and stabilizer down 2 sets of stabilizers down Wide axle rear dozer up | | | | | | | *4500 | 3650 | 3250 | | | | *3200 | 2950 | 2650 | 6.89 |
| 4.5 m | Rear dozer up Rear dozer down Dozer and stabilizer down 2 sets of stabilizers down Wide axle rear dozer up | | | | | | | 4950 | 3600 | 3200 | 3550 | 2600 | 2300 | *3150 | 2500 | 2250 | 7.64 |
| 3.0 m | Rear dozer up Rear dozer down Dozer and stabilizer down 2 sets of stabilizers down Wide axle rear dozer up | | | | *7150 | 5200 | 4550 | 4800 | 3450 | 3100 | 3500 | 2550 | 2250 | 3150 | 2300 | 2050 | 8.03 |
| 1.5 m | Rear dozer up Rear dozer down Dozer and stabilizer down 2 sets of stabilizers down Wide axle rear dozer up | | | | 7050 | 4900 | 4300 | 4650 | 3350 | 2950 | 3450 | 2450 | 2200 | 3050 | 2200 | 1950 | 8.12 |
| 0.0 m | Rear dozer up Rear dozer down Dozer and stabilizer down 2 sets of stabilizers down Wide axle rear dozer up | *5850 | *5850 | *5850 | 6850 | 4700 | 4100 | 4550 | 3200 | 2850 | 3350 | 2400 | 2150 | 3150 | 2250 | 2000 | 7.92 |
| -1.5 m | Rear dozer up Rear dozer down Dozer and stabilizer down 2 sets of stabilizers down Wide axle rear dozer up | *8600 | 8450 | 7000 | 6750 | 4600 | 4000 | 4500 | 3150 | 2800 | | | | 3400 | 2450 | 2150 | 7.40 |
| -3.0 m | Rear dozer up Rear dozer down Dozer and stabilizer down 2 sets of stabilizers down Wide axle rear dozer up | *11 000 | 8500 | 7100 | 6750 | 4600 | 4000 | 4500 | 3150 | 2800 | | | | 4050 | 2900 | 2550 | 6.49 |
| -4.5 m | Rear dozer up Rear dozer down Dozer and stabilizer down 2 sets of stabilizers down Wide axle rear dozer up | *7100 | *7100 | *7100 | *5000 | 4750 | 4100 | | | | | | | *4300 | 4200 | 3650 | 4.95 |

*Limited by hydraulic rather than tipping load.

Lift capacity ratings are based on ISO 10567:2007, they do not exceed 87% of hydraulic lifting capacity or 75% of tipping load. The load point is the center line of the bucket pivot mounting pin on the stick. The oscillating axle must be locked. Lifting capacities are based on the machine standing on a firm uniform supporting surface. For lifting capacity including bucket and/or quick coupler, the respective weight has to be subtracted from above values. The use of a work tool attachment point to handle/lift objects, could affect the machine lift performance.

Always refer to the appropriate Operation and Maintenance Manual for specific product information.

Lift Capacities – Offset Boom (5200 mm)

All values are in kg, without bucket and without QC, with counterweight (4100 kg), heavy lift on.

| Short Stick 2100 mm | Undercarriage configuration | 3.0 m | | | 4.5 m | | | 6.0 m | | | 7.5 m | | | Load point height | | | m |
|------------------------|--|--|-----------------|----------------|-----------------------|-----------------------|----------------------|-----------------------|-----------------------|-----------------------|-----------------------|----------------------|-----------------------|-----------------------|-----------------------|-----------------------|------|
| | | Load at maximum reach (sticknose/bucket pin) | Load over front | Load over rear | Load over side | Load over front | Load over rear | Load over side | Load over front | Load over rear | Load over side | Load over front | Load over rear | Load over side | | | |
| 6.0 m | Rear dozer up Rear dozer down Dozer and stabilizer down 2 sets of stabilizers down Wide axle rear dozer up | | | | *6100 5300 4600 | 5300 5250 6100 | 4600 6100 5050 | 4600 3200 2800 | *4950 4850 4950 | *4950 3200 3050 | | | | *3550 3000 2600 | *3550 3550 3000 | *3550 3550 2850 | 6.20 |
| 4.5 m | Rear dozer up Rear dozer down Dozer and stabilizer down 2 sets of stabilizers down Wide axle rear dozer up | | | | *6500 5000 5000 | *6500 5000 6500 | 4350 5000 4750 | 4550 3150 3150 | *5000 4800 5000 | *5000 3150 3050 | | | | *3250 2400 2050 | *3250 3250 3250 | *3250 2400 2300 | 7.03 |
| 3.0 m | Rear dozer up Rear dozer down Dozer and stabilizer down 2 sets of stabilizers down Wide axle rear dozer up | | | | 6800 *7450 4550 | 4550 *7450 4300 | 3900 4550 4300 | 4400 *5300 3000 | 3000 *5300 3000 | 2600 3000 2850 | | | | 3100 *3200 2100 | 2100 *3200 3200 | 1800 2100 2200 | 7.46 |
| 1.5 m | Rear dozer up Rear dozer down Dozer and stabilizer down 2 sets of stabilizers down Wide axle rear dozer up | | | | 6350 *8500 4200 | 4200 *8500 3950 | 3550 4150 6750 | 4200 *5750 2800 | 2800 *5750 4400 | 2400 2800 5200 | 3000 *4150 2050 | 1750 2050 3200 | 3000 *3350 2000 | 2000 *3350 3150 | 1700 2000 3350 | 1900 | 7.55 |
| 0.0 m | Rear dozer up Rear dozer down Dozer and stabilizer down 2 sets of stabilizers down Wide axle rear dozer up | | | | 6150 *8200 4000 | 4000 *8200 3800 | 3400 4000 7850 | 4050 *6050 2700 | 2700 *6050 2600 | 2300 2700 4300 | | | | 3100 *3600 2050 | 2050 *3600 3250 | 1750 2050 1950 | 7.34 |
| -1.5 m | Rear dozer up Rear dozer down Dozer and stabilizer down 2 sets of stabilizers down Wide axle rear dozer up | *7400 *7400 | *7400 *7400 | 6200 *7400 | 6150 *7100 | 4000 *7100 | 3350 4000 | 4050 *5250 | 2700 *5250 | 2300 2700 | | | | 3450 *4050 | 2300 *4050 | 2000 2350 | 6.77 |
| -3.0 m | Rear dozer up Rear dozer down Dozer and stabilizer down 2 sets of stabilizers down Wide axle rear dozer up | | | | *5000 *5000 | 4150 *5000 | 3500 4100 | | | | | | | | | | |

| Medium Stick 2400 mm | Undercarriage configuration | 3.0 m | | | 4.5 m | | | 6.0 m | | | 7.5 m | | | Load point height | | | m |
|-------------------------|--|--|-----------------|----------------|-----------------------|-----------------------|----------------------|------------------------|------------------------|-----------------------|------------------------|----------------------|------------------------|------------------------|------------------------|-----------------------|------|
| | | Load at maximum reach (sticknose/bucket pin) | Load over front | Load over rear | Load over side | Load over front | Load over rear | Load over side | Load over front | Load over rear | Load over side | Load over front | Load over rear | Load over side | | | |
| 6.0 m | Rear dozer up Rear dozer down Dozer and stabilizer down 2 sets of stabilizers down Wide axle rear dozer up | | | | *5450 5350 4650 | 5350 5450 5450 | 4650 5450 5100 | 4700 *4800 *4800 | 3300 *4800 *4800 | 2850 3250 *4800 | | | | *2950 2750 2800 | 2750 *2950 *2950 | 2400 2750 *2950 | 6.53 |
| 4.5 m | Rear dozer up Rear dozer down Dozer and stabilizer down 2 sets of stabilizers down Wide axle rear dozer up | | | | *6300 5100 5100 | *6300 5100 6300 | 4400 5050 6300 | 4600 *4850 *4850 | 3200 *4850 *4850 | 2800 3200 3050 | | | | *2800 2250 2800 | *2800 2250 *2800 | 1950 2250 *2800 | 7.32 |
| 3.0 m | Rear dozer up Rear dozer down Dozer and stabilizer down 2 sets of stabilizers down Wide axle rear dozer up | | | | 6850 *7150 4650 | 4600 *7150 4400 | 3950 4600 4400 | 4400 *5150 3000 | 3000 *5150 3000 | 2600 3000 2900 | 3100 *4150 2100 | 2100 1800 2000 | *2750 *2750 2000 | 2000 *2750 2000 | 1700 2000 *2750 | 1900 | 7.73 |
| 1.5 m | Rear dozer up Rear dozer down Dozer and stabilizer down 2 sets of stabilizers down Wide axle rear dozer up | | | | 6400 *8400 4200 | 4200 *8400 8100 | 3550 4200 4000 | 4200 *5600 2850 | 2800 *5600 2700 | 2400 2800 4400 | 3000 *4350 2050 | 1800 2050 3200 | *2750 *2850 1900 | 2000 *2850 1900 | 1600 1900 *2850 | 1800 | 7.82 |
| 0.0 m | Rear dozer up Rear dozer down Dozer and stabilizer down 2 sets of stabilizers down Wide axle rear dozer up | | | | 6150 *8300 4000 | 4000 *8300 3750 | 3350 4000 6500 | 4050 *6100 *6100 | 2700 2700 4300 | 2300 2700 5050 | 2950 *4500 *4500 | 2000 1700 3150 | 2900 *3100 *3100 | 1950 *3100 *3100 | 1650 1950 3050 | 1850 | 7.61 |
| -1.5 m | Rear dozer up Rear dozer down Dozer and stabilizer down 2 sets of stabilizers down Wide axle rear dozer up | *7300 *7300 | *7300 *7300 | 6100 *7300 | 6100 *7400 | 3950 *7400 | 3300 6500 | 4000 *5450 | 2650 4250 | 2250 5000 | | | | 3250 *3650 | 2150 *3650 | 1850 2150 | 7.07 |
| -3.0 m | Rear dozer up Rear dozer down Dozer and stabilizer down 2 sets of stabilizers down Wide axle rear dozer up | | | | *5500 *5500 | 4050 *5500 | 3400 4050 | | | | | | | | | | |

*Limited by hydraulic rather than tipping load.

Lift capacity ratings are based on ISO 10567:2007, they do not exceed 87% of hydraulic lifting capacity or 75% of tipping load. The load point is the center line of the bucket pivot mounting pin on the stick. The oscillating axle must be locked. Lifting capacities are based on the machine standing on a firm uniform supporting surface and the Variable Boom Cylinder adjusted to the maximum length. For lifting capacity including bucket and/or quick coupler, the respective weight has to be subtracted from above values. The use of a work tool attachment point to handle/lift objects, could affect the machine lift performance.

Always refer to the appropriate Operation and Maintenance Manual for specific product information.

M316D Wheel Excavator Standard Equipment

Standard equipment may vary. Consult your Cat dealer for details.

Electrical

- Alternator, 75 A
- Lights
 - Boom working light
 - Cab interior light
 - Roading lights two front
 - Roading lights two LED modules rear
 - Rotating beacon on cab
 - Working lights, cab mounted (front and rear)
- Main shut-off switch
- Maintenance free batteries
- Signal/warning horn

Engine

- Automatic engine speed control
- Automatic starting aid
- Cat C6.6 with ACERT Technology
 - EU Stage IIIA compliant
- Fuel/water separator with level indicator

Hydraulics

- Heavy lift mode
- Load-sensing Plus hydraulic system
- Manual work modes (economy, power)
- Separate swing pump
- Stick regeneration circuit

Operator Station

- ROPS cab structure compliant with 2006/42/EC and tested according to ISO 12117-2:2008
- Adjustable armrests
- Air conditioner, heater and defroster with automatic climate control
- Ash tray with cigarette lighter (24 volt)
- Beverage cup/can holder
- Bolt-on FOGS capability
- Bottle holder
- Bottom mounted parallel wiping system that covers the upper and lower windshield glass
- Camera mounted on counterweight displays through cab monitor
- Coat hook
- Floor mat, washable, with storage compartment
- Fully adjustable suspension seat
- Instrument panel and gauges
 - Information and warning messages in local language
 - Gauges for fuel level, engine coolant and hydraulic oil temperature
 - Filters/fluids change interval
 - Indicators for headlights, turning signal, low fuel, engine dial setting
 - Clock with 10-day backup battery
- Laminated front windshield
- Left side console, tiltable, with lock out for all controls
- Literature compartment behind seat
- Literature holder in right console
- Mobile phone holder
- Parking brake
- Positive filtered ventilation
- Power supply, 12V-7A
- Rear window, emergency exit
- Retractable seat belt
- Skylight
- Sliding door windows
- Steering column, tiltable
- Storage area suitable for a lunch box
- Sunshade for windshield and skylight

Undercarriage

- Heavy-duty axles, advanced travel motor, adjustable braking force
- Oscillating front axle with remote greasing
- Tires, 10.00-20 16 PR, dual
- Tool box in undercarriage
- Two-piece drive shaft

Other Equipment

- Automatic swing brake
- Counterweight, 3700 kg
- Mirrors, frame and cab
- Product Link ready

M316D Wheel Excavator Optional Equipment

Optional equipment may vary. Consult your Cat dealer for details.

Auxiliary Controls and Lines

Auxiliary boom and stick lines

Anti-drift valves for bucket, stick, VA boom and tool control/multi-function circuits

Basic control circuits:

Single action

One-way, high pressure circuit, for hammering application

Medium pressure

Two-way, medium pressure circuit, for rotating or tilting of work tools

Tool control/multi function

One/two-way high pressure for hammer application or opening and closing of a work tool

Programmable flow and pressure for up to 10 work tools – selection via monitor

Second high pressure

Additional two-way, high pressure circuit, for tools requiring a second high or medium pressure function

Quick coupler control

Cat BIO HYDO Advanced HEEST™ biodegradable hydraulic oil

Lowering control devices for boom and stick

SmartBoom™

Front Linkage

Booms

One-piece boom, 5050 mm

VA boom (two piece), 5200 mm

Offset boom, 5200 mm

Bucket linkage with diverter valve

Sticks

2100, 2400, 2600 mm

3100 mm industrial with drop nose

Electrical

Back-up alarm with three selectable modes

Heavy-duty maintenance free batteries

Refueling pump

Operator Station

Adjustable hydraulic sensitivity

Falling objects guard

Joystick steering

CD/MP3 Radio (12V) at rear location including speakers and 12V converter

Seat, adjustable high-back

– mechanical suspension

– air suspension (vertical)

– deluxe with headrest, air suspension

Headrest

Travel speed lock

Vandalism guards

Visor for rain protection

Windshield

One-piece high impact resistant

70/30 split, openable

Undercarriage

Dozer blade, front or rear mounted

Outriggers, front and/or rear mounted

Second tool box for undercarriage

Spacer rings for tires

Wide axles

Other Equipment

Auto-lube system

(implements and swing gear)

Cat Machine Security System

Cat Product Link

Counterweight, 4100 kg

Mirrors heated, frame and cab

Ride Control

Tires (see pg.15)

Tool box in upperframe, lockable

Waste Handling Package

M316D Wheel Excavator

For more complete information on Cat products, dealer services, and industry solutions, visit us on the web at www.cat.com

© 2011 Caterpillar Inc.
All rights reserved

Materials and specifications are subject to change without notice. Featured machines in photos may include additional equipment. See your Cat dealer for available options.

CAT, CATERPILLAR, SAFETY.CAT.COM, their respective logos, "Caterpillar Yellow" and the "Power Edge" trade dress, as well as corporate and product identity used herein, are trademarks of Caterpillar and may not be used without permission.

AEHQ6201 (02-2011)

