

390F L

Hydraulic Excavator

2017



Engine

Engine Model	Cat® C18 ACERT™
Power – ISO 14396	405 kW/551 PS
Power – ISO 9249	391 kW/532 PS

Drive

Maximum Travel Speed	4.5 km/h
Maximum Drawbar Pull	590 kN

Weights

Operating Weight – Minimum	86 275 kg
Operating Weight – Maximum	92 020 kg

The 390F L is built to keep your production numbers up and your owning and operating costs down.

Not only does the machine's C18 ACERT engine meet EU Stage IV, U.S. EPA Tier 4 Final and Korea Tier 4 Final emission standards, but it does so while giving you all the power, fuel efficiency, and reliability you need to succeed.

Where the real power comes in is through advanced hydraulics and the new Adaptive Control System (ACS) valve. The ACS valve and other integrated components allow you to move tons of material all day long with a great deal of speed, precision, and efficiency. In fact, the hydraulic system and engine team worked together to lower fuel consumption up to 29% – with zero impact on your productivity – compared to 390D L.

When you add in a quiet operator environment that keeps you comfortable and productive, service points that make your routine maintenance quick and easy, and multiple Cat work tools that help you do a number of jobs very well, you simply won't find a better machine in this size class.

Contents

Reliable and Productive.....	4
Fuel Efficient.....	6
Easy to Operate.....	8
Durable Structures.....	10
Durable Linkages.....	11
Versatile.....	12
Cat Connect Technologies.....	14
Safe Work Environment.....	16
Serviceable.....	17
Sustainable.....	18
Complete Customer Care.....	18
Specifications.....	19
Standard Equipment.....	32
Optional Equipment.....	33
Notes.....	34







Reliable and Productive

Power to move your material with speed and precision

Hydraulic Horsepower, a Cat Advantage

Hydraulic horsepower is the actual machine power available to do work through implements and work tools. It's much more than just the engine power under the hood – it's a core strength that differentiates Cat machines from other brands. In fact, pump and other system components work to put more power to the ground, in a highly controlled, user-friendly way. This means you will move more material in less time and keep more money in your pocket at the end of the day.

Control Like No Other

The new Cat Adaptive Control System (ACS) valve optimizes performance by intelligently managing restrictions and flows to control machine motion, which means your operators will have the power and precision they need and expect. It opens slowly when your range of joystick lever movement is small and opens rapidly when movement is high. It smartly puts flow exactly where you need it when you need it, which leads to smoother operation, greater efficiency, and lower fuel consumption.



SmartBoom™

Reduces Stress and Vibrations Transmitted to the Machine

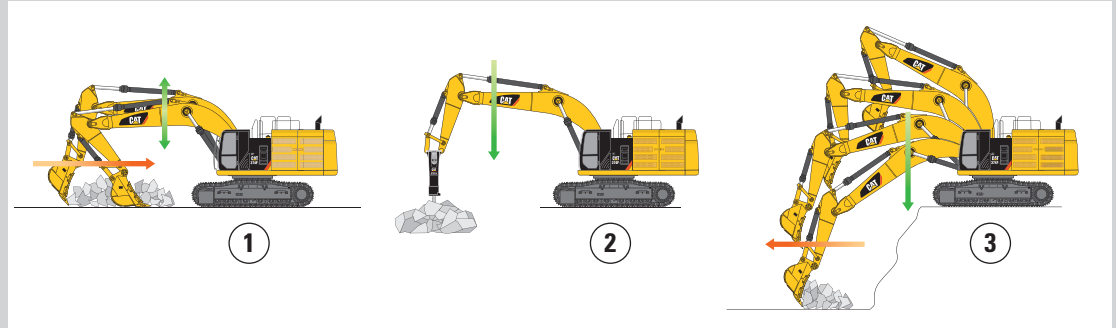

Rock Scraping (1)

Scraping rock and finishing work is easy and fast. SmartBoom simplifies the task and allows the operator to fully concentrate on the stick and bucket while the boom freely goes up and down without using pump flow.

Hammer Work (2)

It has never been this productive and operator-friendly. The front parts automatically follow the hammer while penetrating the rock. Blank shots or excessive force on the hammer are avoided, resulting in longer life for the hammer and machine. Similar advantages are applicable when using vibratory plates.

Truck Loading (3)

Loading trucks from a bench is more productive and fuel efficient as the return cycle is reduced while the boom down function does not require pump flow.

Auxiliary Hydraulics for Added Versatility

Auxiliary hydraulics give you greater tool versatility so you can take on more work with just one machine, and there are several options from which you can choose. A quick coupler circuit, for example, will allow you to switch from one tool to another in a matter of minutes.

Fuel Efficient

Engineered to lower your operating costs





The Cat C18 ACERT engine meets Stage IV and Tier 4 Final emission standards and it does so without interrupting your job process. Simply turn the engine on and go to work. It will look for opportunities in your work cycle to regenerate itself, and it will give you plenty of power for the task at hand – all to help keep your owning and operating costs to an absolute minimum.

A Smart Design for Any Temperature

The 390F L features a side-by-side cooling system that allows you to put the machine to work in extremely hot and cold conditions. The system is completely separated from the engine compartment to reduce noise and heat. Plus it features easy-to-clean cores and a new variable-speed fan that reverses to blow out unwanted debris that may accumulate during your work day.

Biodiesel Not A Problem

The C18 ACERT engine can run on up to B20 biodiesel blended with ULSD. Just fill it up and go.

Proven Technology

The right technologies fine-tuned for the right applications result in:

- **Improved Fuel Efficiency** – Up to 29% improvement over Stage III B and Tier 4 Interim products.
- **High Performance** across a variety of applications.
- **Enhanced Reliability** through commonality and simplicity of design.
- **Maximized Uptime and Reduced Cost** with world-class support from the Cat dealer network.
- **Minimized Impact of Emission Systems** – designed to be transparent to the operator without requiring interaction.
- **Durable Designs** with long life to overhaul.
- **Delivering Better Fuel Economy** with minimized maintenance costs while providing the same great power and response.

Easy to Operate

Comfort and convenience to keep you productive all day long



Safe and Quiet Cab

The cab contributes to your comfort thanks to special viscous mounts and special roof lining and sealing, that limit vibration and unnecessary sound.

Operators will enjoy the quietness and comfort of the all-new cab that's insulated to reduce sound inside by 3 dB over the previous model.

Excellent Ergonomics

Wide seats with air suspension and heat/cooling options, include a reclining back, upper and lower slide adjustments, and height and tilt angle adjustments to meet your needs for maximum comfort.

The fully automatic climate control system keeps operators comfortable and productive all day long in either hot or cold weather.

Storage spaces are located in the front, rear, and side consoles of the cab. A drink holder accommodates a large mug, and a shelf behind the seat stores large lunch or toolboxes.

Power supply sockets are available for charging your electronic devices like an MP3 player, a cell phone, or even a tablet.

Controls Just for You

The right and left joystick consoles can be adjusted to improve your comfort and productivity during the course of a day.

The right joystick features a button that will reduce engine speed when you are not working to help save fuel. Touch it once and speed reduces; touch it again and speed increases for normal operation.

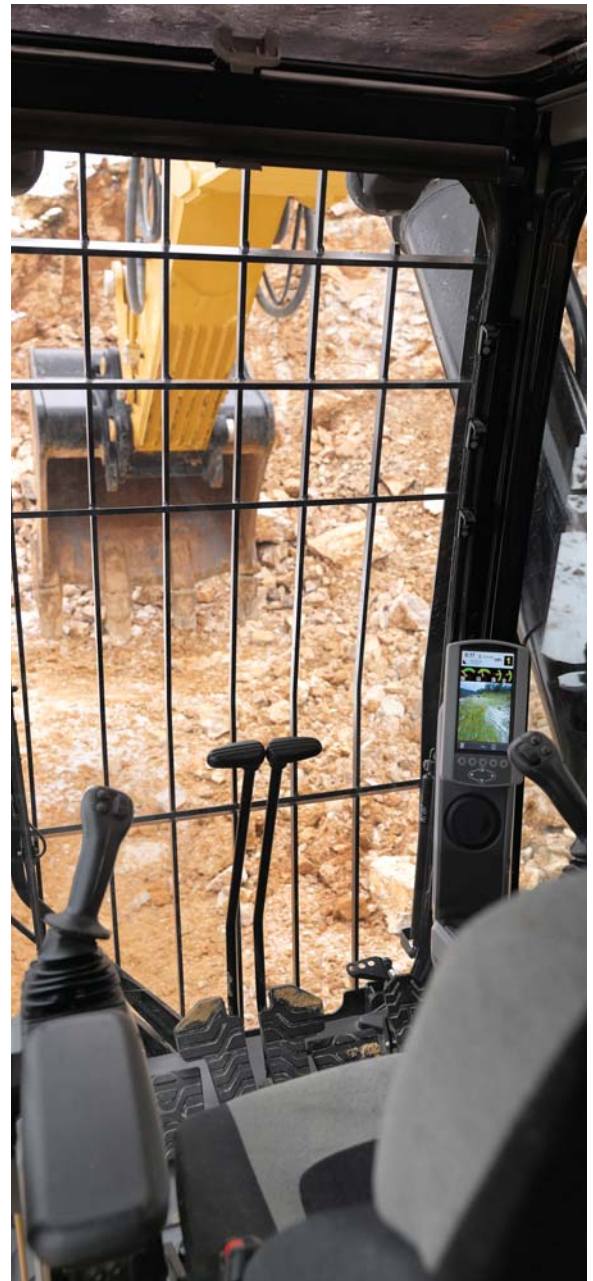

Easy to Navigate Monitor

The new LCD monitor is easy to see and navigate. Not only can it memorize up to 10 different work tools, it's also programmable in up to 44 languages to meet today's diverse workforce. The monitor clearly displays critical information you need to operate efficiently and effectively. Plus it projects the image from the rearview and/or side-view cameras to help you see what's going on around you so you can stay safely focused on the job at hand.

Durable Structures

Designed to work in your tough, heavy-duty applications



Stable Undercarriage

Long variable gauge undercarriage contributes significantly to its outstanding stability and durability, and it adjusts to reduce shipping width.

Track shoes, links, rollers, idlers, and final drives are all built with high-tensile strength steel for long-term durability.

Cat GLT4 track link protects moving parts by keeping water, debris, and dust out and grease sealed in, which delivers longer wear life and reduced noise when traveling.

Cat Positive Pin Retention 2 (PPR2) prevents looseness of the track pin in the track link, reduces stress concentrations, and eliminates pin walking for increased service life.



Robust Frames

The 390F L is a robust, well-built machine designed to give you a very long service life. The upper frame has mountings made specifically to support the heavy-duty cab. It's also reinforced around areas that take on a lot of stress like the boom foot, skirt, and counterweight removal system.

Great Weight

An 12.4 mt counterweight – with or without removal device – is available to balance your work needs. Built with thick steel plates and reinforced fabrications to make it less susceptible to damage, the weight has a curved surface that matches the machine's sleek, smooth appearance along with an integrated housing to help protect the rearview camera.

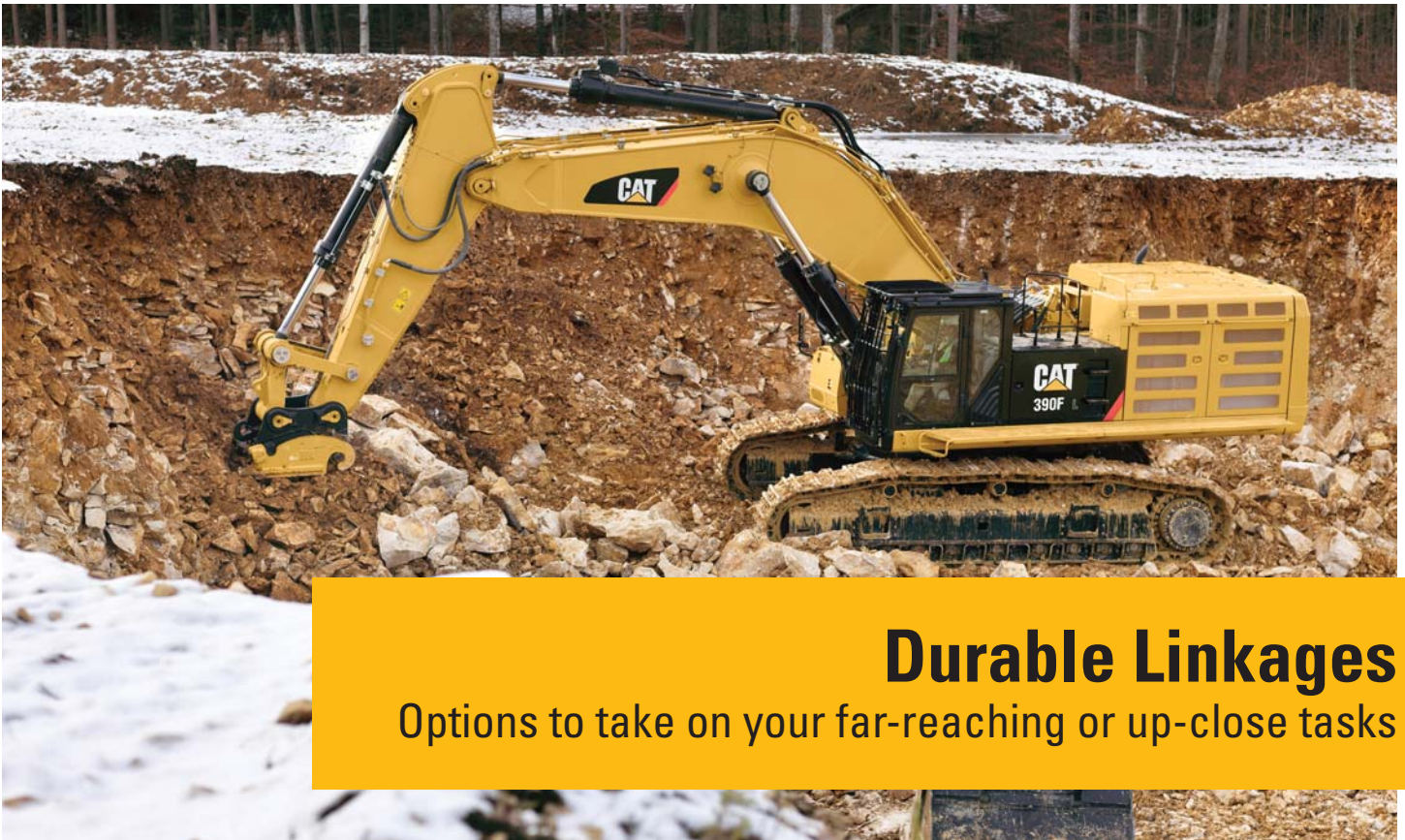

Durable Linkages

Options to take on your far-reaching or up-close tasks

Booms and Sticks for Any Job

The 390F L is offered with a range of booms and sticks. Each is built with internal baffle plates and is stress relieved for added durability, and each undergoes ultrasound inspection to ensure quality and reliability. Large box-section structures with thick, multi-plate fabrications, castings, and forgings are used in high-stress areas such as the boom nose, boom foot, boom cylinder, and stick foot to improve durability. Also, the boom nose pin retention method is a captured flag design for enhanced durability.

The Reach boom and sticks offer you excellent all-around versatility for general excavation work like multipurpose digging and loading.

The Mass boom and sticks offer you enhanced performance in heavy-duty material like rock. They provide higher digging forces due to special boom and stick geometry, and bucket linkage and cylinders are built for greater durability.

Pins

All front linkage pins have thick chrome plating, giving them high wear resistance. Each pin diameter is made to distribute the shear and bending loads associated with the stick and to help ensure long pin, boom and stick life.

Talk to your Cat dealer to pick the best front linkage for your applications.

Versatile

Do more jobs with one machine





Get the Most from One Machine

The Cat combination of machine and tool provides a total solution for just about any application. Work tools can be mounted either directly to the machine or to a quick coupler, making it fast and easy to release one work tool and pick up another.

Change Jobs Quickly

Cat quick coupler brings the ability to quickly change attachments and switch from job to job. The quick coupler is the secure way to decrease downtime and increase job site flexibility and overall productivity.

Available tool control remembers pressures and flows for up to 10 tools. Simply toggle through the monitor, select the tool, and go to work for maximum efficiency.

Dig, Rip and Load

A wide range of buckets dig everything from basic top soil to extreme, harsh material like ore and high quartzite granite. Rip through rock as an alternative to blasting in quarries. High-capacity buckets load trucks in a minimum number of passes for maximum productivity.

Break, Demolish and Scrap

A hydraulic hammer ably equips your machine for breaking rock in quarries. It will also make taking down bridge pillars and heavily reinforced concrete on road demolition jobs no problem.

Multi-processor and pulverizer attachments make your 390F L ideal for demolition jobs and processing the resulting debris.

Shears with 360° rotation mount to the machine for processing scrap steel and metal.

Set Up Your Machine for Profitability

Your Cat dealer can install hydraulic kits to properly operate all Cat Work Tool attachments, maximizing the machine's uptime and your profit. All Cat Work Tool attachments are supported by the same Cat dealer network as your Cat machine.

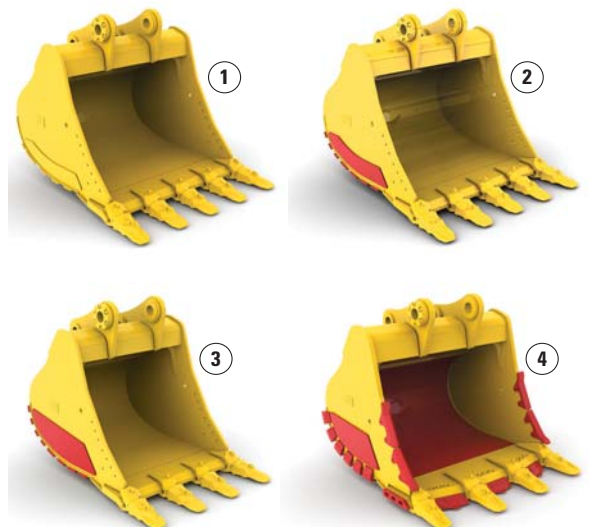

1) General Duty (GD) 2) Heavy Duty (HD)
3) Severe Duty (SD) 4) Extreme Duty (XD)

Cat Connect Technologies

Monitor, manage, and enhance job site operations



Cat Connect makes smart use of technology and services to improve your job site efficiency. Using the data from technology-equipped machines, you'll get more information and insight into your equipment and operations than ever before.

Cat Connect technologies offer improvements in these key areas:



EQUIPMENT
MANAGEMENT

Equipment Management – increase uptime and reduce operating costs.



PRODUCTIVITY

Productivity – monitor production and manage job site efficiency.



SAFETY

Safety – enhance job site awareness to keep your people and equipment safe.

PAYLOAD Technologies

Payload technologies accurately measure material being loaded or hauled. Payload data is shared with operators in real-time to improve productivity, reduce overloading, and record progress.

Cat Production Measurement

Cat Production Measurement brings payload weighing to the cab, enabling operators to weigh loads “on the go.” Loads are weighed as the boom swings with no interruptions in the loading cycle, improving loading speed and efficiency. Operators can view load weights on the integrated display and know precisely how much material is in the bucket and when trucks are filled to target payload. Instant feedback gives operators the confidence to work more effectively, maximizing the potential of the entire fleet. Site managers can wirelessly access data via the VisionLink® web portal to measure production and monitor efficiency.



GRADE Technologies

Grade technologies combine digital design data and in-cab guidance to help you reach target grade quickly and accurately, with minimal staking and checking. That means you'll be more productive, complete jobs faster, in fewer passes, using less fuel, at a lower cost.



Cat Grade 3D

Cat Grade 3D is perfect for complex excavating projects that require precise cuts and contours. The 254 mm (10 in) color monitor shows you exactly where to work and how much to cut or fill without staking or grade checking, delivering accuracy within 30 mm (1.18 in). Factory integration of most key components reduces field installation time and labor cost, making the system less costly for you compared to other options. Plus reliability is enhanced because built-in components are protected from damage, ensuring longer service life and more accurate results.

Cat Grade with Assist

Cat Grade with Assist ensures you can dig a level base with the right slope each and every time; now it works with tilt buckets to give you even greater versatility. With a touch of a button, the simple-to-use system automates boom and bucket movements typically done by the operator. Regardless of your experience or skill, you will be able to reach target grade up to 45% faster than with traditional grading techniques.

Cat AccuGrade™

The AccuGrade system uses a dedicated monitor with a digital design plan for 3D bucket tip positioning and elevation guidance. AccuGrade indicates precisely where to work and how much to cut or fill – eliminating staking and checking.

Plug and play capability on the machine simplifies upgrading. Choose from satellite (GNSS) or total station (UTS) control for large projects with complex designs.

LINK Technologies

LINK technologies, like Product Link™, are deeply integrated into your machine and wirelessly communicates key information, including location, hours, fuel usage, idle time and event codes.

Product Link/VisionLink

Easy access to Product Link data via the online VisionLink user interface can help you see how your machine or fleet is performing. You can use this information to make timely, fact based decisions that can boost job site efficiency and productivity, and lower costs.



Safe Work Environment

Features to help protect you day in and day out



Great Views

Ample glass gives you excellent visibility out front and to the side. The new rearview and side-view cameras greatly enhance visibility behind and on the side of the machine to help the operator work more productively. A panoramic rearview is automatically displayed on the new multi-function monitor during reverse travel. As an option, a second display can be added, providing a dedicated full-time rearview of the job site.

Halogen lights provide plenty of illumination. Cab and boom lights can be programmed to stay on for up to 90 seconds after the engine has been turned off to help you safely exit the machine. Optional High Intensity Discharge (HID) lights are available for enhanced night-time visibility.

Secure Contact Points

Multiple large steps as well as hand and guard rails will get you into the cab as well as a leg up to the catwalks and compartments. Extended hand and guard rails allow you to safely climb to the upper deck. Anti-skid plates on the catwalks, the surface of the upper structure, and the top of the storage box area reduce your slipping hazards in all types of weather conditions. They can be removed for cleaning.

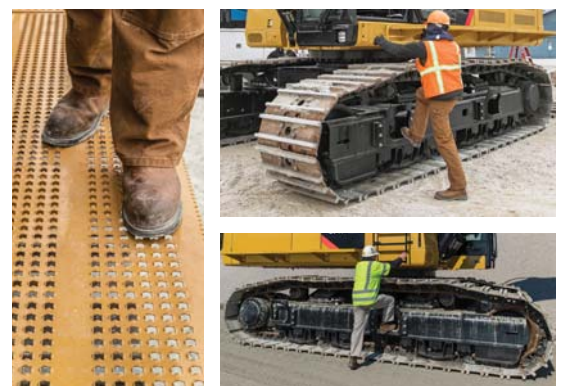

Serviceable

Designed to make your maintenance quick and easy

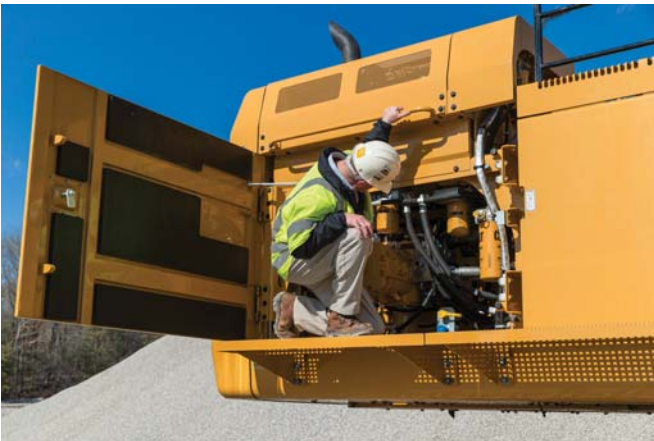

Convenient Access Built In

You can reach routine maintenance items like greasing points and a concentrated remote greasing block on boom foot from ground level.

Compartments feature wide service doors designed to help prevent debris entry, and they also securely latch in place to help make your service work simpler.

Machine's slip-resistant 500 mm wide catwalks stretch the length of the machine to provide safe access to major and grouped service points, such as fuel and oil filters, and fluid taps.



Quick and Convenient Fluids Service

S-O-SSM Oil sample and pressure ports provide easy checking of machine condition and are standard on every machine.

You can ensure fast, easy, and secure changing of engine and hydraulic oil with the QuickEvacTM option.

The fuel tank's drain cock makes it easy and simple for you to remove water and sediment during routine maintenance. Plus an integrated fuel level indicator pops up to help you reduce the possibility of fuel tank overfilling. An optional fast fill port accessible from ground level can make refueling even easier and faster.

An electric refueling pump allows you to refuel from other sources like a barrel or fuel reservoir when a fuel truck or regular fuel pump isn't on site. The pump automatically shuts off when the fuel tank is full.



A Smart Cooling Design

The 390F L features a new side-by-side cooling system with easy-to-clean cores and a new variable-speed fan that reverses to blow out unwanted debris that may accumulate during your work day.



Complete Customer Care

Unmatched support makes the difference

Sustainable Generations ahead in every way

The 390F L is designed to compliment your business plan and minimize the consumption of natural resources, resulting in fewer emissions.

- The C18 ACERT engine meets Stage IV and Tier 4 Final emission standards.
- The 390F L has the flexibility to run on either ultra-low-sulfur diesel fuel (ULSD with 15 ppm of sulfur or less) or up to B20 biodiesel blended with ULSD.
- An overfill indicator rises when the tank is full to help the operator avoid spilling.
- Quick fill ports with connectors ensure fast, easy, and secure changing of hydraulic oil.
- Major components are rebuildable, eliminating waste and saving money by giving the machine and/or major components a second life – and even a third life.
- Link technologies enable you to collect and analyze equipment and job site data so you can maximize productivity and reduce costs.
- The 390F L is an efficient, productive machine that's designed to conserve our natural resources for generations ahead.

Worldwide Parts Availability

Cat dealers utilize a worldwide parts network to maximize your machines' uptime. Plus they can help you save money with Cat remanufactured components.

Financial Options Just for You

Consider financing options and day-to-day operating costs. Look at dealer services that can be included in the machine's cost to yield lower owning and operating costs over time.

What's Best for You Today...and Tomorrow

Repair, rebuild, or replace? Your Cat dealer can help you evaluate the cost involved so you can make the best choice for your business.



390F L Hydraulic Excavator Specifications

Engine

Engine Model	Cat C18 ACERT
Power – ISO 14396	405 kW/551 PS/543 hp
Power – ISO 9249	391 kW/532 PS/524 hp
Bore	145 mm
Stroke	183 mm
Displacement	18.1 L
<ul style="list-style-type: none"> • No engine power derating required below 2300 m altitude. • Rating at 1,700 rpm (Implement). 	

Drive

Gradeability	40°
Maximum Travel Speed	4.5 km/h
Maximum Drawbar Pull	590 kN

Track

Track Options	900 mm 750 mm 650 mm
Number of Shoes Each Side	51
Number of Track Rollers Each Side	9
Number of Carrier Rollers Each Side	3

Swing Mechanism

Swing Speed	6.2 rpm
Swing Torque	260 kN·m
Maximum Swing Torque	313 kN·m

Service Refill Capacities

Fuel Tank Capacity	1240 L
Cooling System	74 L
Engine Oil	60 L
Swing Drive (each)	19 L
Final Drive (each)	21 L
Hydraulic System Oil Capacity (including tank)	997 L
Hydraulic Tank Oil	813 L
DEF Tank	48 L

Sound Performance

Exterior – ISO 6395*	109 dB(A)*
Interior – SAE J1166/ISO 6396	74 dB(A)

- Hearing protection may be needed when operating with an open operator station and cab (when not properly maintained or doors/windows open) for extended periods or in a noisy environment.
- When properly installed and maintained, the cab offered by Caterpillar, when tested with doors and windows closed according to ANSI/SAE J1166 OCT98, meets OSHA and MSHA requirements for operator sound exposure limits in effect at time of manufacture.

* As per European Union Directive 2000/14/EC as amended by 2005/88/EC.

Hydraulic System

Maximum Flow (total)	
Main System – Implement	952 L/min
Main System – Travel	1064 L/min
Swing System	No swing pump
Pilot System	67 L/min
Maximum Pressure	
Equipment – Normal	35 000 kPa
Travel	35 000 kPa
Swing	26 000 kPa
Pilot System	4.0-4.4 MPa
Boom Cylinder	
Bore	210 mm
Stroke	1967 mm
Stick Cylinder	
Bore	220 mm
Stroke	2262 mm
HB2 – Family Bucket Cylinder	
Bore	200 mm
Stroke	1451 mm
JC – Family Bucket Cylinder	
Bore	220 mm
Stroke	1586 mm

Standards

Brakes	ISO 10265:2008
Cab/FOGS	SAE J1356/MAR2013 ISO 10262:1998
DEF	ISO 22241

390F L Hydraulic Excavator Specifications

Dimensions

All dimensions are approximate. Dimensions may vary depending on bucket selection.

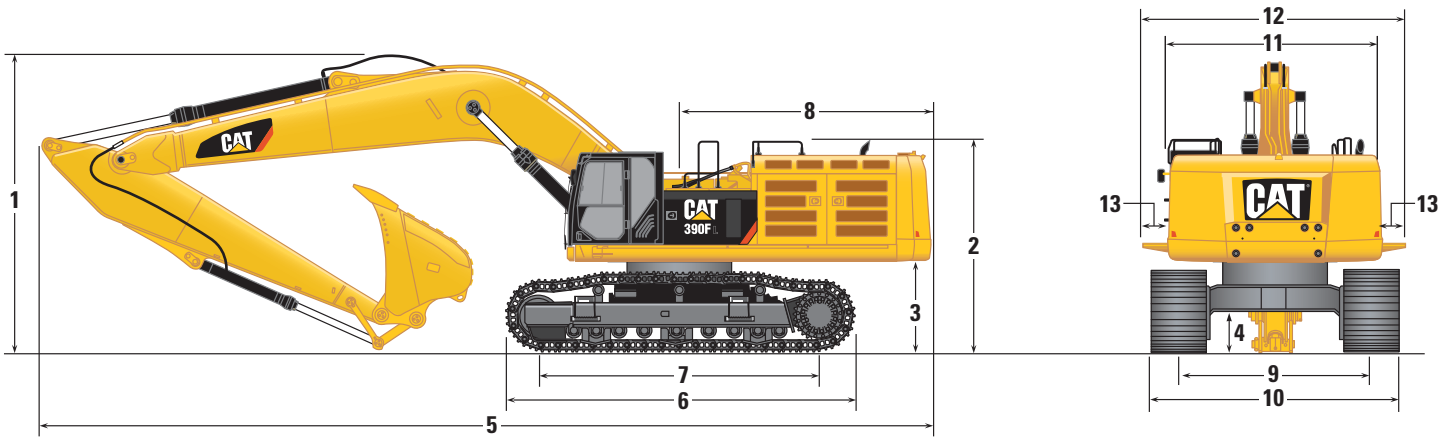

Boom Options	Reach Boom 10.0 m		General Purpose Boom 8.4 m			Mass Boom* 7.25 m	
Stick Options	R5.5 m	R4.4 m	R5.5 m	R4.4 m	G3.4 m	M3.4 m	M2.92 m
1 Height – with boom/stick installed	5490 mm	5070 mm	5840 mm	5290 mm	5160 mm	5310 mm	4890 mm
2 Guardrail Height	3830 mm	3830 mm	3830 mm	3830 mm	3830 mm	3830 mm	3830 mm
3 Counterweight Clearance	1640 mm	1640 mm	1640 mm	1640 mm	1640 mm	1640 mm	1640 mm
4 Ground Clearance	900 mm	900 mm	900 mm	900 mm	900 mm	900 mm	900 mm
5 Length – with boom/stick installed	16 290 mm	16 330 mm	14 500 mm	14 690 mm	14 720 mm	13 550 mm	13 690 mm
6 Track Length	6358 mm	6358 mm	6358 mm	6358 mm	6358 mm	6358 mm	6358 mm
7 Length to Center of Rollers	5120 mm	5120 mm	5120 mm	5120 mm	5120 mm	5120 mm	5120 mm
8 Tail Swing Radius	4700 mm	4700 mm	4700 mm	4700 mm	4700 mm	4700 mm	4700 mm
9 Track Gauge – retracted	2750 mm	2750 mm	2750 mm	2750 mm	2750 mm	2750 mm	2750 mm
Track Gauge – extended	3510 mm	3510 mm	3510 mm	3510 mm	3510 mm	3510 mm	3510 mm
10 Undercarriage Width – without steps							
650 mm Shoes	4160 mm	4160 mm	4160 mm	4160 mm	4160 mm	4160 mm	4160 mm
750 mm Shoes	4260 mm	4260 mm	4260 mm	4260 mm	4260 mm	4260 mm	4260 mm
900 mm Shoes	4410 mm	4410 mm	4410 mm	4410 mm	4410 mm	4410 mm	4410 mm
Undercarriage Width – including steps							
650 mm Shoes	4450 mm	4450 mm	4450 mm	4450 mm	4450 mm	4450 mm	4450 mm
750 mm Shoes	4450 mm	4450 mm	4450 mm	4450 mm	4450 mm	4450 mm	4450 mm
900 mm Shoes	4450 mm	4450 mm	4450 mm	4450 mm	4450 mm	4450 mm	4450 mm
11 Upperframe Width – without walkways	3470 mm	3470 mm	3470 mm	3470 mm	3470 mm	3470 mm	3470 mm
12 Upperframe Width – with walkways	4510 mm	4510 mm	4510 mm	4510 mm	4510 mm	4510 mm	4510 mm
13 Walkway Width (each)	520 mm	520 mm	520 mm	520 mm	520 mm	520 mm	520 mm
Bucket Type	GD	GD	GD	GD	SD	SDV	SDV
Bucket Capacity	3.9 m ³	3.9 m ³	4.6 m ³	4.6 m ³	4.6 m ³	6.0 m ³	6.0 m ³
Bucket Tip Radius	2424 mm	2424 mm	2319 mm	2319 mm	2319 mm	2505 mm	2505 mm

*Mass boom is the only boom available for South Korea.

390F L Hydraulic Excavator Specifications

Working Ranges

All dimensions are approximate. Dimensions may vary depending on bucket selection.

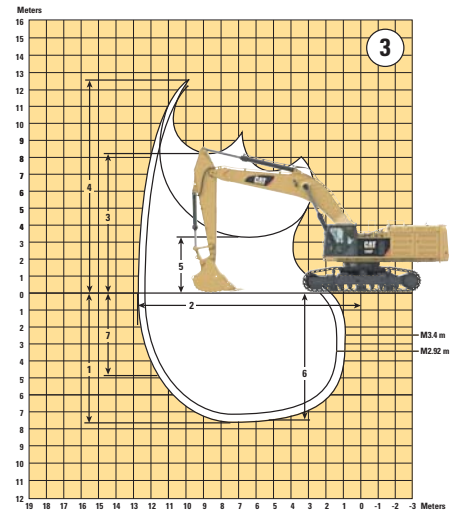
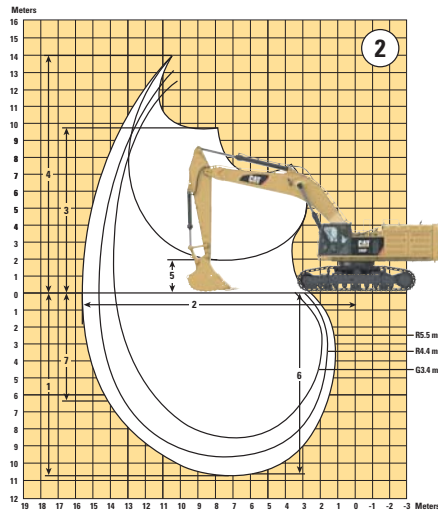
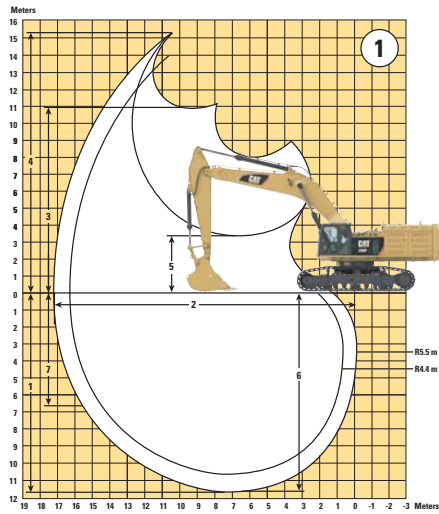

Boom Options

	① Reach Boom 10.0 m		② General Purpose Boom 8.4 m			③ Mass Boom* 7.25 m	
Stick Options	R5.5 m	R4.4 m	R5.5 m	R4.4 m	G3.4 m	M3.4 m	M2.92 m
1 Maximum Digging Depth	11 800 mm	10 700 mm	10 750 mm	9650 mm	8680 mm	7640 mm	7160 mm
2 Maximum Reach at Ground Line	17 250 mm	16 230 mm	15 730 mm	14 690 mm	13 910 mm	12 680 mm	12 230 mm
3 Maximum Loading Height	10 960 mm	10 530 mm	9730 mm	9280 mm	9100 mm	8210 mm	7990 mm
4 Maximum Cutting Height	15 180 mm	14 750 mm	14 000 mm	13 540 mm	13 470 mm	12 580 mm	12 360 mm
5 Minimum Loading Height	3320 mm	4420 mm	1950 mm	3050 mm	4030 mm	3210 mm	3680 mm
6 Maximum Depth Cut for 2240 mm Level Bottom	11 700 mm	10 590 mm	10 650 mm	9540 mm	8550 mm	7510 mm	7020 mm
7 Maximum Vertical Wall Digging Depth	6670 mm	5730 mm	6330 mm	5390 mm	5960 mm	4920 mm	4530 mm
Bucket Digging Force (ISO)	364.8 kN	363.3 kN	364.8 kN	363.3 kN	470.9 kN	470.9 kN	470.4 kN
Stick Digging Force (ISO)	235.9 kN	276.0 kN	235.9 kN	276.0 kN	325.5 kN	325.5 kN	356.3 kN
Bucket Type	GD	GD	GD	GD	SD	SDV	SDV
Bucket Capacity	3.9 m ³	3.9 m ³	4.6 m ³	4.6 m ³	4.6 m ³	6.0 m ³	6.0 m ³
Bucket Tip Radius	2424 mm	2424 mm	2319 mm	2319 mm	2319 mm	2505 mm	2505 mm

*Mass boom is the only boom available for South Korea.

390F L Hydraulic Excavator Specifications

Operating Weights and Ground Pressures

Boom	Stick	Bucket	900 mm Shoes		750 mm Shoes		650 mm Shoes	
			Weight	Ground Pressure	Weight	Ground Pressure	Weight	Ground Pressure
R10.0 m	R5.5 m	3.9 m ³	89 827 kg	88.1 kPa	88 780 kg	104.5 kPa	87 906 kg	119.4 kPa
R10.0 m	R4.4 m	3.9 m ³	89 319 kg	87.6 kPa	88 272 kg	103.9 kPa	87 398 kg	118.7 kPa
GP8.4 m	R5.5 m	4.6 m ³	88 704 kg	87.0 kPa	87 657 kg	103.2 kPa	86 783 kg	117.8 kPa
GP8.4 m	R4.4 m	4.6 m ³	88 196 kg	86.5 kPa	87 149 kg	102.6 kPa	86 275 kg	117.2 kPa
GP8.4 m	G3.4 m	4.6 m ³	90 603 kg	88.9 kPa	89 556 kg	105.4 kPa	88 682 kg	120.4 kPa
M7.25 m	M3.4 m	6.0 m ³	92 022 kg	90.3 kPa	90 975 kg	107.1 kPa	90 101 kg	122.4 kPa
M7.25 m	M2.92 m	6.0 m ³	91 764 kg	90.0 kPa	90 717 kg	106.8 kPa	89 843 kg	122.0 kPa

Major Components Weights

Base Machine (with counterweight, without front linkage, without bucket)*	kg
650 mm Tracks	66 739
750 mm Tracks	67 613
900 mm Tracks	68 660
Two Boom Cylinders	1804
Counterweight	
Removal Type	12 400
Non-removal Type	12 400
Boom (includes lines, pins, stick cylinder)	
Reach Boom – 10.0 m	9839
General Purpose Boom – 8.4 m	8392
Mass Boom – 7.25 m	8437
Stick (includes lines, pins, bucket cylinder, linkage)	
R5.5 m	5430
R4.4 m	4922
G3.4 m	5186
M3.4 m	5447
M2.92 m	5189
Bucket	
3.9 m ³ GD	4094
4.6 m ³ GD	4418
6.0 m ³ SDV	7674

*Base machine includes 75 kg operator weight and 90% fuel weight, and undercarriage with center guard.

390F L Hydraulic Excavator Specifications

Reach Boom Lift Capacities – Counterweight: 12.4 mt – Without Bucket

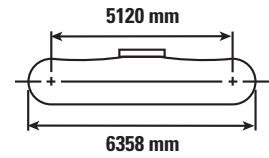
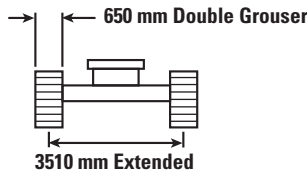
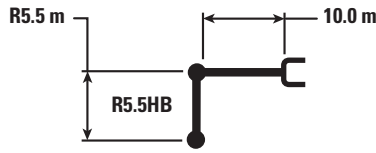

		1500 mm		3000 mm		4500 mm		6000 mm		7500 mm		mm		
12 000 mm	kg											*9600	*9600	11 830
10 500 mm	kg											*9300	*9300	12 880
9000 mm	kg											*9150	9050	13 680
7500 mm	kg											*9150	8150	14 280
6000 mm	kg									*19 800	*19 800	*9250	7500	14 690
4500 mm	kg							*28 600	*28 600	*22 050	22 000	*9500	7050	14 950
3000 mm	kg							*20 000	*20 000	*24 050	20 300	*9900	6800	15 050
1500 mm	kg							*15 650	*15 650	*25 400	18 950	*10 450	6700	14 990
0 mm	kg							*16 950	*16 950	*25 950	18 150	10 650	6700	14 790
-1500 mm	kg					*11 250	*11 250	*20 650	*20 650	*25 800	17 700	10 950	6900	14 420
-3000 mm	kg			*12 200	*12 200	*16 750	*16 750	*26 100	24 700	*24 950	17 500	11 550	7300	13 880
-4500 mm	kg			*17 800	*17 800	*22 900	*22 900	*28 300	24 950	*23 400	17 600	*11 800	7950	13 140
-6000 mm	kg			*24 050	*24 050	*30 050	*30 050	*25 150	*25 150	*21 100	17 850	*11 500	9050	12 170
-7500 mm	kg					*24 250	*24 250	*20 850	*20 850	*17 700	*17 700	*10 850	*10 850	10 910
-9000 mm	kg							*14 850	*14 850	*12 650	*12 650	*9250	*9250	9230

		9000 mm		10 500 mm		12 000 mm		13 500 mm		15 000 mm		mm		
12 000 mm	kg											*9600	*9600	11 830
10 500 mm	kg					*12 100	12 000					*9300	*9300	12 880
9000 mm	kg			*13 350	*13 350	*12 550	11 850	*10 050	9300			*9150	9050	13 680
7500 mm	kg			*14 000	*14 000	*12 900	11 500	*12 100	9150			*9150	8150	14 280
6000 mm	kg	*16 850	*16 850	*14 850	13 900	*13 400	11 100	*12 350	8900			*9250	7500	14 690
4500 mm	kg	*18 250	16 750	*15 750	13 200	*14 000	10 600	*12 700	8600			*9500	7050	14 950
3000 mm	kg	*19 550	15 650	*16 600	12 450	*14 550	10 100	12 800	8300	*10 250	6850	*9900	6800	15 050
1500 mm	kg	*20 550	14 750	*17 300	11 850	14 950	9650	12 450	8000			*10 450	6700	14 990
0 mm	kg	*21 100	14 100	*17 700	11 350	14 600	9300	12 200	7750			10 650	6700	14 790
-1500 mm	kg	*21 150	13 650	17 400	11 000	14 300	9050	12 050	7600			10 950	6900	14 420
-3000 mm	kg	*20 650	13 450	17 200	10 800	14 200	8950	12 000	7550			11 550	7300	13 880
-4500 mm	kg	*19 550	13 450	*16 450	10 800	*13 850	8950					*11 800	7950	13 140
-6000 mm	kg	*17 700	13 650	*14 800	10 950	*11 900	9200					*11 500	9050	12 170
-7500 mm	kg	*14 800	14 050	*11 800	11 400							*10 850	*10 850	10 910
-9000 mm	kg	*9800	*9800									*9250	*9250	9230



ISO 10567



*Indicates that the load is limited by hydraulic lifting capacity rather than tipping load. The above loads are in compliance with hydraulic excavator lift capacity standard ISO 10567:2007. They do not exceed 87% of hydraulic lifting capacity or 75% of tipping load. Weight of all lifting accessories must be deducted from the above lifting capacities. Lifting capacities are based on the machine standing on a firm, uniform supporting surface. The use of a work tool attachment point to handle/lift objects, could affect the machine lift performance.

Lift capacity stays with ±5% for all available track shoes.

Always refer to the appropriate Operation and Maintenance Manual for specific product information.

390F L Hydraulic Excavator Specifications

Reach Boom Lift Capacities – Counterweight: 12.4 mt – Without Bucket

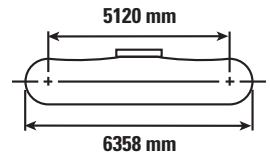
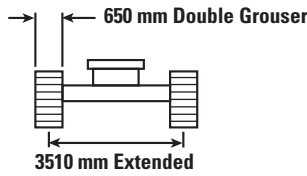
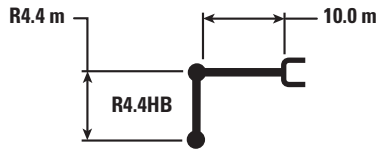

Reach Boom Lift Configuration	3000 mm		4500 mm		6000 mm		7500 mm		Reach Boom Lift Configuration		mm
12 000 mm	kg								*12 950	*12 950	10 510
10 500 mm	kg								*12 450	12 200	11 680
9000 mm	kg								*12 250	10 500	12 560
7500 mm	kg								*12 250	9400	13 210
6000 mm	kg				*28 100	*28 100	*21 950	*21 950	*12 450	8600	13 660
4500 mm	kg						*24 050	21 100	12 400	8100	13 940
3000 mm	kg						*25 700	19 650	12 050	7800	14 040
1500 mm	kg						*26 450	18 700	11 950	7700	13 980
0 mm	kg				*13 250	*13 250	*26 400	18 200	12 100	7750	13 760
-1500 mm	kg				*20 150	*20 150	*25 600	18 000	12 550	8050	13 370
-3000 mm	kg		*18 050	*18 050	*28 450	25 550	*24 200	18 050	*13 050	8600	12 780
-4500 mm	kg		*26 900	*26 900	*25 800	*25 800	*22 100	18 250	*12 800	9500	11 970
-6000 mm	kg		*24 450	*24 450	*22 000	*22 000	*19 100	18 700	*12 150	11 100	10 900
-7500 mm	kg				*16 750	*16 750	*14 650	*14 650	*10 750	*10 750	9460

Reach Boom Lift Configuration	9000 mm		10 500 mm		12 000 mm		13 500 mm		Reach Boom Lift Configuration		mm	
12 000 mm	kg		*13 000	*13 000					*12 950	*12 950	10 510	
10 500 mm	kg		*14 450	*14 450					*12 450	12 200	11 680	
9000 mm	kg		*14 750	14 750	*13 800	11 500			*12 250	10 500	12 560	
7500 mm	kg	*17 150	*17 150	*15 300	14 250	*14 050	11 300		*12 250	9400	13 210	
6000 mm	kg	*18 400	17 350	*16 100	13 650	*14 500	10 900	13 300	8800	*12 450	8600	13 660
4500 mm	kg	*19 700	16 300	*16 900	12 950	*14 950	10 500	13 050	8600	12 400	8100	13 940
3000 mm	kg	*20 750	15 350	*17 600	12 350	*15 350	10 100	12 800	8350	12 050	7800	14 040
1500 mm	kg	*21 450	14 650	*18 050	11 850	15 000	9750	12 600	8100	11 950	7700	13 980
0 mm	kg	*21 650	14 150	17 850	11 450	14 750	9450	12 400	7950	12 100	7750	13 760
-1500 mm	kg	*21 300	13 900	17 650	11 200	14 550	9300			12 550	8050	13 370
-3000 mm	kg	*20 350	13 850	*17 200	11 150	*14 500	9300			*13 050	8600	12 780
-4500 mm	kg	*18 750	14 000	*15 750	11 250					*12 800	9500	11 970
-6000 mm	kg	*16 150	14 300	*13 100	11 650					*12 150	11 100	10 900
-7500 mm	kg	*11 850	*11 850							*10 750	*10 750	9460



ISO 10567



*Indicates that the load is limited by hydraulic lifting capacity rather than tipping load. The above loads are in compliance with hydraulic excavator lift capacity standard ISO 10567:2007. They do not exceed 87% of hydraulic lifting capacity or 75% of tipping load. Weight of all lifting accessories must be deducted from the above lifting capacities. Lifting capacities are based on the machine standing on a firm, uniform supporting surface. The use of a work tool attachment point to handle/lift objects, could affect the machine lift performance.

Lift capacity stays with ±5% for all available track shoes.

Always refer to the appropriate Operation and Maintenance Manual for specific product information.

390F L Hydraulic Excavator Specifications

General Purpose Boom Lift Capacities – Counterweight: 12.4 mt – Without Bucket

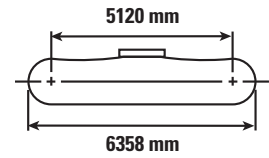
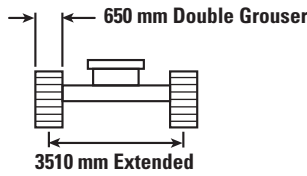
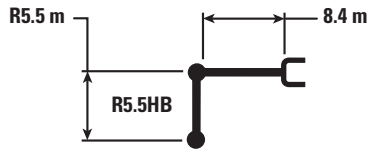

		1500 mm		3000 mm		4500 mm		6000 mm		7500 mm		mm		
														mm
12 000 mm	kg											*8950	*8950	9840
10 500 mm	kg											*8350	*8350	11 080
9000 mm	kg											*8050	*8050	12 010
7500 mm	kg											*7950	*7950	12 680
6000 mm	kg											*7950	*7950	13 150
4500 mm	kg							*26 650	*26 650	*21 800	*21 800	*8100	*8100	13 440
3000 mm	kg							*31 000	*31 000	*24 350	22 750	*8450	*8450	13 550
1500 mm	kg							*34 200	29 800	*26 450	21 500	*8900	8850	13 490
0 mm	kg					*18 900	*18 900	*35 800	28 500	*27 750	20 600	*9600	8950	13 260
-1500 mm	kg			*14 150	*14 150	*23 150	*23 150	*35 900	27 800	*28 150	20 000	*10 550	9250	12 840
-3000 mm	kg	*16 300	*16 300	*20 100	*20 100	*29 350	*29 350	*34 700	27 600	*27 550	19 750	*12 050	9950	12 230
-4500 mm	kg	*22 150	*22 150	*27 000	*27 000	*37 700	*37 700	*32 150	27 700	*25 850	19 750	*14 300	11 050	11 390
-6000 mm	kg			*35 500	*35 500	*35 100	*35 100	*28 000	*28 000	*22 650	20 000	*14 450	13 050	10 250
-7500 mm	kg					*26 500	*26 500	*21 600	*21 600	*17 150	*17 150	*13 200	*13 200	8710

		9000 mm		10 500 mm		12 000 mm		13 500 mm		15 000 mm		mm		
														mm
12 000 mm	kg											*8950	*8950	9840
10 500 mm	kg			*10 850	*10 850							*8350	*8350	11 080
9000 mm	kg			*12 900	*12 900	*8050	*8050					*8050	*8050	12 010
7500 mm	kg			*14 300	*14 300	*11 400	*11 400					*7950	*7950	12 680
6000 mm	kg	*17 300	*17 300	*15 850	14 750	*13 400	11 650					*7950	*7950	13 150
4500 mm	kg	*18 800	18 200	*16 800	14 200	*15 250	11 350					*8100	*8100	13 440
3000 mm	kg	*20 400	17 300	*17 800	13 650	*15 950	11 000	*8850	*8850			*8450	*8450	13 550
1500 mm	kg	*21 750	16 500	*18 650	13 100	15 950	10 650					*8900	8850	13 490
0 mm	kg	*22 700	15 850	19 150	12 700	15 650	10 400					*9600	8950	13 260
-1500 mm	kg	*23 000	15 400	18 800	12 350	15 450	10 200					*10 550	9250	12 840
-3000 mm	kg	*22 550	15 200	18 650	12 250	*15 350	10 200					*12 050	9950	12 230
-4500 mm	kg	*21 150	15 200	*17 250	12 300							*14 300	11 050	11 390
-6000 mm	kg	*18 250	15 450									*14 450	13 050	10 250
-7500 mm	kg											*13 200	*13 200	8710



ISO 10567



*Indicates that the load is limited by hydraulic lifting capacity rather than tipping load. The above loads are in compliance with hydraulic excavator lift capacity standard ISO 10567:2007. They do not exceed 87% of hydraulic lifting capacity or 75% of tipping load. Weight of all lifting accessories must be deducted from the above lifting capacities. Lifting capacities are based on the machine standing on a firm, uniform supporting surface. The use of a work tool attachment point to handle/lift objects, could affect the machine lift performance.









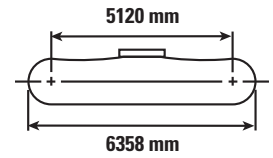
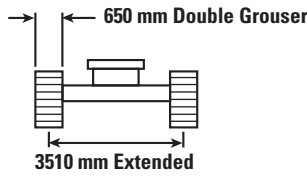
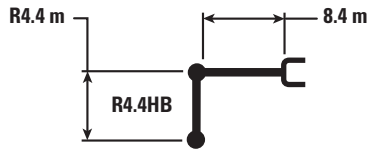

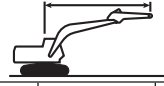
Lift capacity stays with ±5% for all available track shoes.











Always refer to the appropriate Operation and Maintenance Manual for specific product information.

390F L Hydraulic Excavator Specifications

General Purpose Boom Lift Capacities – Counterweight: 12.4 mt – Without Bucket



		1500 mm		3000 mm		4500 mm		6000 mm				mm
												
10 500 mm	kg									*11 350	*11 350	9800
9000 mm	kg									*10 900	*10 900	10 830
7500 mm	kg									*10 700	*10 700	11 580
6000 mm	kg									*10 750	*10 750	12 090
4500 mm	kg							*30 400	*30 400	*11 050	10 650	12 400
3000 mm	kg							*34 100	30 700	*11 500	10 250	12 520
1500 mm	kg							*36 200	29 150	*12 200	10 150	12 460
0 mm	kg							*36 500	28 400	*13 300	10 350	12 210
-1500 mm	kg					*24 050	*24 050	*35 450	28 100	*14 850	10 850	11 760
-3000 mm	kg			*23 500	*23 500	*33 450	*33 450	*33 200	28 150	*16 450	11 800	11 080
-4500 mm	kg			*33 150	*33 150	*36 200	*36 200	*29 500	28 500	*16 050	13 500	10 140
-6000 mm	kg					*28 650	*28 650	*23 900	*23 900	*14 950	*14 950	8840

		7500 mm		9000 mm		10 500 mm		12 000 mm				mm
												
10 500 mm	kg			*15 400	*15 400					*11 350	*11 350	9800
9000 mm	kg			*17 300	*17 300	*13 350	*13 350			*10 900	*10 900	10 830
7500 mm	kg			*18 000	*18 000	*16 850	14 800			*10 700	*10 700	11 580
6000 mm	kg	*21 850	*21 850	*19 200	18 600	*17 450	14 450	*11 750	11 450	*10 750	*10 750	12 090
4500 mm	kg	*24 200	23 500	*20 600	17 800	*18 200	14 000	*15 150	11 250	*11 050	10 650	12 400
3000 mm	kg	*26 400	22 200	*21 900	17 050	*19 000	13 550	16 300	11 000	*11 500	10 250	12 520
1500 mm	kg	*28 000	21 200	*22 950	16 400	*19 550	13 100	16 000	10 750	*12 200	10 150	12 460
0 mm	kg	*28 650	20 550	*23 450	15 900	19 250	12 800	15 850	10 600	*13 300	10 350	12 210
-1500 mm	kg	*28 300	20 200	*23 200	15 600	19 050	12 600			*14 850	10 850	11 760
-3000 mm	kg	*26 850	20 150	*22 050	15 550	*18 050	12 600			*16 450	11 800	11 080
-4500 mm	kg	*24 150	20 350	*19 600	15 750					*16 050	13 500	10 140
-6000 mm	kg	*19 400	*19 400							*14 950	*14 950	8840



ISO 10567



*Indicates that the load is limited by hydraulic lifting capacity rather than tipping load. The above loads are in compliance with hydraulic excavator lift capacity standard ISO 10567:2007. They do not exceed 87% of hydraulic lifting capacity or 75% of tipping load. Weight of all lifting accessories must be deducted from the above lifting capacities. Lifting capacities are based on the machine standing on a firm, uniform supporting surface. The use of a work tool attachment point to handle/lift objects, could affect the machine lift performance.









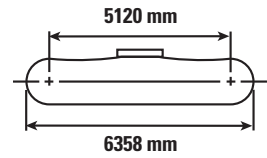
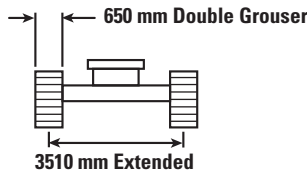
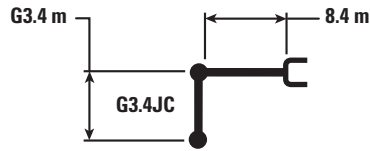



Lift capacity stays with ±5% for all available track shoes.

Always refer to the appropriate Operation and Maintenance Manual for specific product information.

390F L Hydraulic Excavator Specifications

General Purpose Boom Lift Capacities – Counterweight: 12.4 mt – Without Bucket



		4500 mm		6000 mm		7500 mm		9000 mm		10 500 mm				mm
														
10 500 mm	kg											*15 450	*15 450	8740
9000 mm	kg							*18 750	18 750			*14 500	*14 500	9890
7500 mm	kg					*21 450	*21 450	*19 250	18 350	*17 150	14 050	*14 100	13 550	10 710
6000 mm	kg			*28 700	*28 700	*23 350	*23 350	*20 200	17 750	*18 250	13 800	*14 050	12 200	11 260
4500 mm	kg			*32 800	31 050	*25 500	22 400	*21 400	17 050	*18 800	13 400	*14 250	11 400	11 590
3000 mm	kg					*27 300	21 250	*22 450	16 350	*19 300	13 000	*14 800	10 950	11 720
1500 mm	kg					*28 250	20 450	*23 100	15 800	19 150	12 650	*15 650	10 900	11 650
0 mm	kg			*33 250	27 850	*28 200	20 000	*23 100	15 450	18 900	12 450	16 850	11 150	11 380
-1500 mm	kg	*21 450	*21 450	*33 300	27 900	*27 150	19 850	*22 300	15 350	*18 250	12 400	*17 050	11 850	10 900
-3000 mm	kg	*35 400	*35 400	*30 150	28 150	*24 900	20 000	*20 350	15 450			*16 600	13 200	10 170
-4500 mm	kg	*29 450	*29 450	*25 450	*25 450	*21 000	20 400	*16 050	15 900			*15 500	*15 500	9130
-6000 mm	kg			*18 000	*18 000	*13 500	*13 500					*13 000	*13 000	7610



ISO 10567



*Indicates that the load is limited by hydraulic lifting capacity rather than tipping load. The above loads are in compliance with hydraulic excavator lift capacity standard ISO 10567:2007. They do not exceed 87% of hydraulic lifting capacity or 75% of tipping load. Weight of all lifting accessories must be deducted from the above lifting capacities. Lifting capacities are based on the machine standing on a firm, uniform supporting surface. The use of a work tool attachment point to handle/lift objects, could affect the machine lift performance.

Lift capacity stays with ±5% for all available track shoes.

Always refer to the appropriate Operation and Maintenance Manual for specific product information.

390F L Hydraulic Excavator Specifications

Mass Boom Lift Capacities – Counterweight: 12.4 mt – Without Bucket

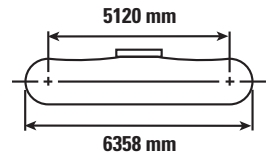
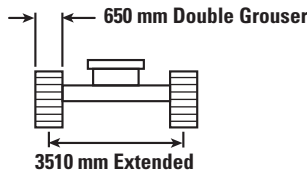
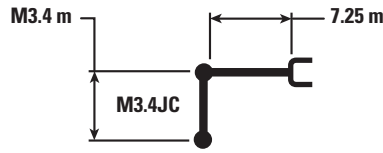

		3000 mm		4500 mm		6000 mm		7500 mm		9000 mm		mm		
10 500 mm	kg											*17 250	*17 250	6970
9000 mm	kg							*21 550	*21 550			*15 800	*15 800	8380
7500 mm	kg							*23 200	*23 200	*18 850	18 400	*15 200	*15 200	9330
6000 mm	kg					*29 000	*29 000	*24 600	24 400	*21 850	18 050	*15 100	*15 100	9960
4500 mm	kg			*45 150	*45 150	*32 650	*32 650	*26 450	23 350	*22 700	17 500	*15 450	13 950	10 330
3000 mm	kg					*35 800	31 100	*28 100	22 250	*23 500	16 950	*16 200	13 350	10 480
1500 mm	kg					*37 200	29 750	*29 050	21 400	*23 850	16 400	*17 450	13 300	10 400
0 mm	kg			*27 900	*27 900	*36 650	29 100	*28 900	20 900	*23 450	16 100	*19 400	13 700	10 100
-1500 mm	kg	*23 500	*23 500	*41 650	*41 650	*34 200	28 900	*27 250	20 700	*21 650	16 000	*19 450	14 800	9550
-3000 mm	kg	*38 650	*38 650	*36 350	*36 350	*29 650	29 150	*23 550	20 850			*18 450	17 050	8700
-4500 mm	kg			*26 650	*26 650	*22 050	*22 050					*15 900	*15 900	7450



ISO 10567



*Indicates that the load is limited by hydraulic lifting capacity rather than tipping load. The above loads are in compliance with hydraulic excavator lift capacity standard ISO 10567:2007. They do not exceed 87% of hydraulic lifting capacity or 75% of tipping load. Weight of all lifting accessories must be deducted from the above lifting capacities. Lifting capacities are based on the machine standing on a firm, uniform supporting surface. The use of a work tool attachment point to handle/lift objects, could affect the machine lift performance.

Lift capacity stays with ±5% for all available track shoes.

Always refer to the appropriate Operation and Maintenance Manual for specific product information.

390F L Hydraulic Excavator Specifications

Mass Boom Lift Capacities – Counterweight: 12.4 mt – Without Bucket

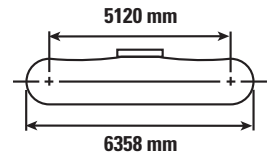
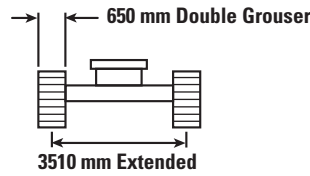
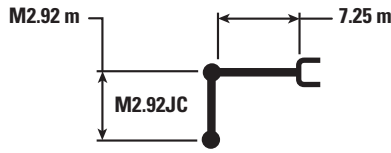

		3000 mm		4500 mm		6000 mm		7500 mm		9000 mm		mm		
10 500 mm	kg											*21 000	*21 000	6290
9000 mm	kg							*22 700	*22 700			*19 000	*19 000	7820
7500 mm	kg							*24 400	*24 400			*18 200	*18 200	8830
6000 mm	kg			*39 800	*39 800	*30 550	*30 550	*25 650	24 200	*22 750	17 950	*18 150	16 350	9500
4500 mm	kg					*34 050	32 600	*27 350	23 150	*23 400	17 450	*18 550	15 000	9890
3000 mm	kg					*36 700	30 800	*28 800	22 200	*23 950	16 950	*19 550	14 350	10 040
1500 mm	kg					*37 450	29 650	*29 400	21 450	*24 100	16 500	*21 150	14 250	9960
0 mm	kg			*26 100	*26 100	*36 200	29 200	*28 800	21 000	*23 250	16 250	*20 900	14 800	9640
-1500 mm	kg			*40 200	*40 200	*33 100	29 150	*26 600	20 900	*20 550	16 300	*20 250	16 150	9060
-3000 mm	kg			*33 150	*33 150	*27 850	*27 850	*21 950	21 250			*18 800	*18 800	8170
-4500 mm	kg					*18 750	*18 750					*15 650	*15 650	6740



ISO 10567



*Indicates that the load is limited by hydraulic lifting capacity rather than tipping load. The above loads are in compliance with hydraulic excavator lift capacity standard ISO 10567:2007. They do not exceed 87% of hydraulic lifting capacity or 75% of tipping load. Weight of all lifting accessories must be deducted from the above lifting capacities. Lifting capacities are based on the machine standing on a firm, uniform supporting surface. The use of a work tool attachment point to handle/lift objects, could affect the machine lift performance.

Lift capacity stays with ±5% for all available track shoes.

Always refer to the appropriate Operation and Maintenance Manual for specific product information.

390F L Hydraulic Excavator Specifications

Bucket Specifications and Compatibility

	Linkage	Width	Capacity	Weight	Fill	Reach Boom		General Purpose Boom			Mass Boom	
		mm	m ³	kg	%	R5.5 m	R4.4 m	R5.5 m	R4.4 m	G3.4 m	M3.4 m	M2.92 m
Without Quick Coupler												
General Duty (GD)	HB2	1100	2.2	2856	100	⊖	●	●	●			
	HB2	1350	2.9	3187	100	◇	⊖	⊙	●			
	HB2	1650	3.7	3650	100	⊗	◇	○	⊙			
	HB2	1900	4.3	3923	100	⊗	⊗	○	⊖			
	HB2	2000	4.6	4032	100	⊗	⊗	◇	○			
Heavy Duty (HD)	JC	1750	4.1	4799	100					⊖	●	●
Severe Duty (SD)	JC	2300	5.4	6809	90					◇	⊖	⊙
	JC	2400	5.7	7015	90					◇	⊖	⊙
	JC	2500	6.0	7342	90					⊗	○	⊖
Extreme Duty (XD)	JC	2200	5.0	6557	90					◇	⊙	●
	JC	2300	5.4	7733	90					⊗	○	⊖
	JC	2400	5.7	7968	90					◇	○	⊖
Maximum dynamic load pin on (payload + bucket)					kg	6350	7535	8850	10 420	11 430	14 600	15 850
With Quick Coupler (CW-70)												
Severe Duty (SD)	JC	2300	5.4	6559	90					⊗	○	⊖
	JC	2400	5.7	6765	90					⊗	○	⊖
Maximum dynamic load with CW coupler (payload + bucket)					kg	4930	6115	7430	9000	10 010	13 180	14 430

Maximum Material Density

- 2100 kg/m³ or greater
- ⊙ 1800 kg/m³ or greater
- ⊖ 1500 kg/m³ or less
- 1200 kg/m³ or less
- ◇ 900 kg/m³ or less
- ⊗ Not Recommended

The above figures are based on maximum recommended dynamic working weights with front linkage fully extended at ground line with bucket curled. They do not exceed a stability ratio of 1.25.

Capacity based on ISO 7451.

Bucket weights include HD Long tips.

Caterpillar recommends using appropriate work tools to maximize the value customers receive from our products. Use of work tools, including buckets, which are outside of Caterpillar's recommendations or specifications for weight, dimensions, flows, pressures, etc. may result in less-than-optimal performance, including but not limited to reductions in production, stability, reliability, and component durability. Improper use of a work tool resulting in sweeping, prying, twisting and/or catching of heavy loads will reduce the life of the boom and stick.

390F L Hydraulic Excavator Specifications

Work Tool Offering Guide*

Boom Options	Reach Boom 10.0 m		General Purpose Boom 8.4 m			Mass Boom 7.25 m	
Stick Options	R5.5 m HD	R4.4 m HD	R5.5 m HD	R4.4 m HD	G3.4 m HD	M3.4 m	M2.92 m
Multi-Processor		MP40 CC Jaw MP40 CR Jaw MP40 PS Jaw MP40 S Jaw		MP40 CC Jaw MP40 CR Jaw MP40 PS Jaw MP40 S Jaw			
Crusher	P360	P360	P360	P360			
Mobile Scrap and Demolition Shear		S365C		S365C	S385C	S385C	S385C
Orange Peel Grapple							
Rippers							
Center-Lock™ Pin Grabber							
Coupler							
Dedicated Quick Coupler							

These work tools are available for the 390F L.
Consult your Cat dealer for proper match.

*Matches are dependent on excavator configurations. Consult your Cat dealer for proper work tool match.

390F L Standard Equipment

Standard Equipment

Standard equipment may vary. Consult your Cat dealer for details.

CAB

- Parallel wiper and washer
- Mirrors
- Pressurized operator station with positive filtration
- Laminated glass front upper window and tempered other windows
- Sliding upper door window (left-hand cab door)
- Removable lower windshield with in cab storage bracket
- Openable skylight
- Interior:
 - Glass-breaking safety hammer
 - Coat hook
 - Beverage holder
 - Literature holder
 - Interior lighting
 - Radio mounting
 - Two 12V stereo speakers
 - Storage shelf suitable for lunch or toolbox
 - Power supply with 12V, two power outlets (10 amp)
 - Thumb wheel modulation joystick for use with combined auxiliary control
 - Air conditioner, heater and defroster with climate control
- Seat:
 - Seat belt, 51 mm
 - Adjustable armrest
 - Height adjustable joystick consoles
 - Neutral lever (lock out) for all controls
 - Travel control pedals with removable hand levers
 - Capability of installing two additional pedals
 - Two speed travel
 - Floor mat, washable

Monitor:

- Clock
- Video ready
- Color LCD display with warning, filter/fluid change, and working hour information
- Language display (full graphic and full color display)
- Machine condition, error code and tool mode setting information
- Start-up level check for engine oil, engine coolant and hydraulic oil
- Warning, filter/fluid change and working hour information
- Fuel consumption meter

ELECTRICAL

- 80 amp alternator
- Circuit breaker
- Battery, standard
- Beacon electrical outlet

ENGINE

- C18 ACERT diesel engine
- Meets EU Stage IV, U.S. EPA Tier 4 Final and Korea Tier 4 Final emission standards
- 2300 m altitude capability with no derate
- Up to B20 biodiesel capable
- Automatic engine speed control
- Electric priming pump with switch
- Water separator in fuel line including water level sensor and indicator
- Economy and standard power modes
- Air cleaner
- Side-by-side cooling system
- Steel wall between engine and pump compartment
- Primary filter with water separator and water separator indicator switch
- Starting kit, cold weather, –18° C
- Primary fuel filter
- Secondary fuel filter
- Tertiary fuel filter

HYDRAULIC SYSTEM

- Reverse swing dampening valve
- Automatic swing parking brake
- High-performance hydraulic return filter
- Regeneration circuit for boom and stick
- Capability of installing additional auxiliary circuits
- Reversing cooling fan
- Bio oil capable
- SmartBoom

LIGHTS

- Cab and boom lights with time delay
- Exterior lights integrated into storage box

UNDERCARRIAGE/UPPERFRAME

- Grease Lubricated Track with PPR2 GLT4, resin seal
- Heavy duty track roller and idler
- Heavy duty track motor guards
- Towing eye on base frame
- Heavy duty bottom guards on upperframe
- Counterweight with lifting eye
- Swivel guard

SAFETY AND SECURITY

- Cat one key security system
- Door locks
- Cap locks on fuel and hydraulic tanks
- Lockable external tool/storage box
- Signaling/warning horn
- Secondary engine shutoff switch
- Mirrors
- Rear window for emergency exit
- Capability to connect a beacon
- Bolt on FOGS capability
- Service walkways
- Safety hammer for breaking cab glass

INTEGRATED TECHNOLOGIES

- Product Link
- Rearview camera

Optional Equipment

Optional equipment may vary. Consult your Cat dealer for details.

FRONT LINKAGE

- Reach boom (10.0 m):*, **
 - R5.5HB2
 - R4.4HB2
- General Purpose boom (8.4 m):*, **
 - R5.5HB2
 - R4.4HB2
 - G3.4JC
- Mass boom (7.25 m):
 - M3.4JC
 - M2.9JC
- JC-family bucket linkage (with or without lifting eye)
- HB2-family bucket linkage (with or without lifting eye)
- Cat Quick Coupler

TRACK

- 650 mm double grouser heavy duty
- 750 mm double grouser heavy duty
- 900 mm double grouser heavy duty*

COUNTERWEIGHT

- With removal device
- Fixed

ENGINE

- Quick drains, engine and hydraulic oil (QuickEvac)
- Fast fill port for fuel

GUARDS

- FOGS (Falling Object Guard System) including overhead and windshield guards
- TOP guard including overhead guards**
- Track guiding guards:
 - Full length, two pieces
 - Segmented, three pieces

LIGHTS

- Cab working lights, halogen
- Cab working lights, HID**, ***
- Boom working lights, halogen
- Boom working lights, HID

CAB

- Seat:
 - Adjustable high-back, heated seat with air or mechanical suspension***
 - Adjustable high-back, heated and ventilated seat with air suspension*, **
- Windshield:
 - 70-30 split, sliding
 - One-piece, fixed*
- Straight travel pedal
- Interior:
 - Sun screen

HYDRAULIC SYSTEM

- Boom and stick lowering control devices
- Counterweight removal device
- HP hydraulic lines for boom and stick
- MP hydraulic lines for boom and stick
- QC hydraulic lines for boom and stick
- QC control

ELECTRICAL

- Cold weather starting package, 240V*
- Travel alarm
- Electric refueling pump with auto shutoff*, **

CAT CONNECT TECHNOLOGIES

- Cat Production Measurement
- Cat Grade Control 3D
- Cat Grade Assist
- Cat AccuGrade
- Side-view camera

*for Europe only

**for ANZ only

***for South Korea only

For more complete information on Cat products, dealer services, and industry solutions, visit us on the web at www.cat.com

© 2017 Caterpillar
All rights reserved

Materials and specifications are subject to change without notice. Featured machines in photos may include additional equipment. See your Cat dealer for available options.

CAT, CATERPILLAR, SAFETY.CAT.COM, their respective logos, "Caterpillar Yellow" and the "Power Edge" trade dress, as well as corporate and product identity used herein, are trademarks of Caterpillar and may not be used without permission.

VisionLink is a trademark of Trimble Navigation Limited, registered in the United States and in other countries.

AEHQ8029
(Europe, Israel, ANZ,
South Korea)

