

6018/6018 FS

Hydraulic Shovel



Engine*

Engine Model	2 × Cat® C18 ACERT™	
Gross Power – SAE J1995	858 kW	1,150 hp
Net Power – SAE J1349	824 kW	1,104 hp

*Electric drive option available (650 kW) on 6018 AC/6018 AC FS

Bucket

Bucket Capacity – Front Shovel (heaped 2:1)	10.0 m ³	13.1 yd ³
Bucket Capacity – Backhoe (heaped 1:1)	10.0 m ³	13.1 yd ³

Operating Specifications

Bucket Payload	18 tonnes	20 tons
Operating Weight – Front Shovel	183 tonnes	202 tons
Operating Weight – Backhoe	186 tonnes	205 tons

6018/6018 FS Features

With over 190 deliveries world-wide, the Cat 6018/6018 FS has proven itself as a durable and versatile hydraulic shovel. Along with much of the same advanced technology available on its larger Cat counterparts, the 6018/6018 FS offers the productivity capability and facilitates the mobility and flexibility you need from a 180 tonne machine. When optimally paired with our 773, 775, or 777 Series off-highway trucks, you'll experience the operational efficiency and productivity you're looking for, supported by our unmatched Cat dealer network.

Contents

Drive Systems.....	4
Twin-engine Concept.....	5
TriPower System (Front Shovel Machines)....	6
Hydraulic System.....	8
Independent Oil Cooling System.....	9
Pump Managing System.....	10
Closed-loop Swing Circuit.....	11
Operator's Cab.....	12
Electronic Control System.....	13
Cat MineStar™ System and Technology Solutions.....	14
Loading/Hauling Efficiency.....	16
Front Attachment Options and Structures....	17
Swing System.....	18
Undercarriage.....	19
Safety.....	20
Serviceability.....	21
Customer Support.....	22
Sustainability.....	24
Specifications.....	25
Optional Equipment.....	35



Every Day Matters, Every Load Counts



We understand the challenges you face, the importance of reliability, and the relationship between uptime and productivity. That's why we continually strive to produce the safest, most reliable and productive hydraulic shovels possible. Offering the widest payload range of any manufacturer in the industry, the ability to optimally pair with our popular line of mining trucks, and the support of our world-class Cat dealer network, we are uniquely positioned to partner with you to help achieve your productivity targets. We understand what matters to you. Our hydraulic shovels are built with you in mind. Because in mining, every day matters and every load counts.

Drive Systems

Balanced Combination of Power and Efficiency



Meeting Your Site Specific Needs with a Choice of Robust Drive System Options

Giving you the option to choose the drive system best suited for your operation, the Cat 6018/6018 FS can be equipped with either two Cat C18 diesel engines for greater mobility, or an electric drive for better efficiency.

- **Reliable Cat C18 ACERT Engine**

Delivering durable, reliable power that will keep your primary loading tool producing, the C18 has proven its ability to stand-up to the harshest mining conditions, providing the mobility and flexibility you need. In addition, they're backed by our world-class dealer network, ready to provide service and support when needed.

- **Efficient Electric Drive System on 6018 AC/6018 AC FS**

Providing a lower cost-per-ton alternative to diesel powered hydraulic shovels, our electric drive option maintains the ruggedness you need and offers superior availability since no refueling and less service is required.

This solution is ideal for operations that do not require a great deal of mobility and value a low cost-per-ton model.



Twin-engine Concept

Stay Up and Running More Consistently

Keep Producing and Ensure the Safety of Your Operators, Even During Single Engine Loss

You will realize enhanced safety, greater uptime, more productivity, and better serviceability as a result of our twin-engine concept.

- **Enhanced Safety**

The ability to move your shovel to a safe area for repair, away from high walls, blast zones, or other safety hazards, is still possible with the use of a single engine.

- **Greater Uptime and More Productivity**

Up to 65% of full production can still be achieved with the use of a single engine. This is due to the shovel's continued ability to exert maximum digging forces, to lower the front attachment without requiring engine power (i.e., pressure-free), and to recuperate energy via its closed-loop swing circuit.

- **Better Serviceability**

Troubleshooting is greatly simplified and expedited with the ability to compare one engine versus the other.

TriPower System (Front Shovel Machines)

Superior Digging Capability and Bucket Fill Factors



Dig More Effectively with Our Unique TriPower Front Shovel Design

You will experience enhanced, easier and faster front shovel operation with TriPower, a system proven on over a thousand Cat hydraulic shovels worldwide. Generating superior mechanical leverage and control, our FS configured hydraulic shovels utilize a unique boom design that employs rotatable triangular rockers. This design facilitates quicker cycle times, increased effective lifting force, constant boom momentum, automatic constant bucket angle, and automatic roll-back limiter.



- **Quicker Cycle Times**

- Faster lifting speeds are achieved, because the design enables the use of smaller-diameter boom cylinders.

- **Increased Effective Lifting Force**

- Design transfers digging forces into the superstructure, creating supporting boom momentum in addition to momentum that is generated hydraulically.

- **Constant Boom Momentum**

- Allows smaller boom cylinders for higher lifting speed.
- Keeps lifting speed constant.
- Enables the shovel to lift a single load along the entire digging distance.
- No retracting of stick cylinders is required, ensuring that all hydraulic pumps are supplying the boom-up function.

- **Automatic Constant Bucket Angle**

- Material spillage is avoided during boom lifting, because the filled bucket automatically maintains a constant bucket angle.
- On conventional kinematics the operator has to control manually the bucket position during lifting which cut in half the available oil flow for the boom cylinders.

- **Automatic Roll-back Limiter**

- Preventing material spillage back on to the operator's cab and machine superstructure, our system ensures that the bucket is always in a safe position, without operator control/manipulation, when it is at maximum height.
- The boom cylinder continues to receive maximum oil flow, because the operator does not need to activate the bucket cylinder.

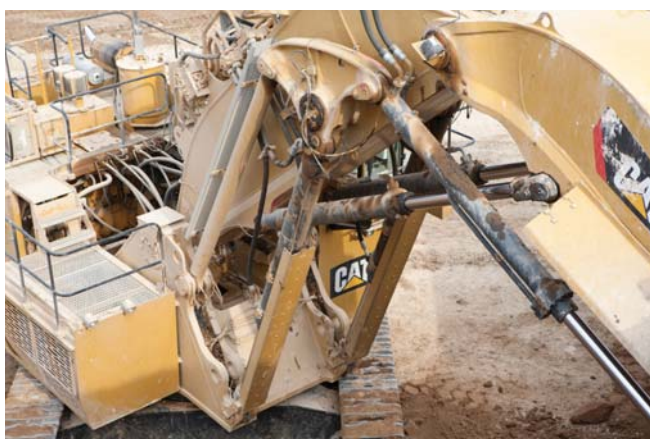

Hydraulic System

Easy Serviceability and Greater Productivity



Straightforward, Safe System Maintenance

Ensuring neat organization for safe operation, easy inspection, and fast service, and reducing the number of hoses needed, the main valve block is located on top of the boom.

Faster Cycle Times

Faster cycle times are realized, because float valves are used to lower the boom instead of engaging pumps. This facilitates faster boom movements and allows other operating functions to occur simultaneously, such as bucket curl and stick in/out.





Independent Oil Cooling System

More Effective Oil Cooling for Extended Component Life

Protect and Extend the Life of Your Hydraulic Components and Seals

Providing a more efficient means of cooling, particularly in demanding applications, our unique independent oil cooling system will extend the life of your hydraulic shovel's components.

More Efficient Oil Cooling

Our system is independent of return oil, achieving efficiency through the utilization of dedicated pumps that provide cooling capacity as needed, whether the engine is idling or under load. That means optimum oil temperature is being maintained, even while your operator waits for the next truck to load. Competitive hydraulic shovels only provide cooling when the machine is working and the engine is under load.

Additional efficiency is achieved via our electronically controlled radiator fan speed. The fans do not run until oil temperature exceeds a temperature of 50° C (122° F), saving energy.

Optimal Oil Temperature Maintained

The high-efficient oil cooling system ensures that the oil temperature is only 25° to 30° C (45° to 54° F) higher than the ambient temperature. Thus the hydraulic oil working temperature ranges within the optimal operating viscosity range of 50° to 70° C (122° to 158° F).

Experience Improved Machine Control and Component Life, while Reducing Fuel Consumption and Noise Emission, with Our Intelligent Pump Managing System

Delivering optimal performance, our pump managing system continuously evaluates actual engine and hydraulic operating values against set values, and adjusts pump output accordingly. This results in efficient use of the engine for greater productivity.

Pump managing system advantages include:

- Best possible utilization of engine output and engine overload avoidance via electronic load limit regulation
- Less energy consumption and less thermal load on hydraulic oil with zero oil flow regulation for main pumps
- Less fuel consumption and lower noise emission via automatic RPM reduction
- Reduced component wear and lower noise emission with automatic oil flow reduction for closing/opening of bucket clam
- Protection of components with automatic oil flow reduction if hydraulic and/or engine coolant temperature exceed set maximum
- Improved operator control response via on-demand pump flow

Pump Managing System

Enhanced Efficiency, Component Life,
and Control Response



Closed-loop Swing Circuit

More Efficient Energy Use and
Faster Boom Lift Motion During Swing



Load More Material, at Lower Cost, with the Energy Recovery Capability of Our Closed-loop Swing System

Delivering faster cycle times and improved energy efficiency, while also generating less heat, our closed-loop swing circuit provides distinct advantages over competitive machines utilizing open-circuit swing systems.

Greater Efficiency via Energy Recovery

Kinetic energy captured during the swing motion is fed back into the system during deceleration, providing more power to drive the main and auxiliary pumps. Energy is saved during deceleration, because braking occurs via counteracting controls, as opposed to throttles used in open circuit swing systems.

Energy Savings During Acceleration

Energy is saved during acceleration via torque control, providing a pressure balance valve that controls the swing pump against pressure in the closed-loop swing circuit, ensuring that only the minimum necessary oil flow is utilized at any given time.

Faster Cycle Times

Faster boom lift motion during swing is achieved with our closed-loop swing system, increasing overall productivity.

Operator's Cab

Ensuring the Safety and Comfort of Your Operators



Get Peak Operator Performance with Our Safe and Comfortable Operator's Cab

We understand that the most important factor in your hydraulic shovel's effectiveness is the performance of its operator. To help make their workday as productive as possible, we've incorporated safety and comfort features into the 6018/6018 FS operator's cab.



Protection for Your Operator; Every Day, Every Shift

- Safety glass is used for all cab windows, and armored glass for the windshield.
- Operator's seat is equipped with integrated safety switch that automatically neutralizes the hydraulic controls when the operator leaves the seat.
- The height of the cab module ensures an eye level of approximately 5.4 m (17 ft 9 in), providing excellent visibility of the digging and loading areas.
- Cab meets Falling Object Protection System (FOPS) and DIN ISO 3449 standards.

Supporting Peak Operator Performance with Comfort Features

- Pneumatically cushioned, multi-adjustable operator's seat.
- Large, transfective color touch-screen display provides vital machine monitoring and diagnostic data for convenient troubleshooting and service assistance.
- Enhanced control response and servo adjustment capability via electro-hydraulic servo control.



Electronic Control System

Operate with Confidence

Enhanced Control Response and Optimized Hydraulic Engine Load Management

Help your team meet productivity and performance standards with our intuitive, informative on-board electronics.

Electro-Hydraulic Servo Control

- **Enhanced Control Response**

The system relays actuating signals from the joysticks, delivering fast and precise machine reactions facilitate a reduction in operator fatigue.

- **Increased Uptime**

Uptime is increased as a result of simplified troubleshooting and advanced diagnostic capabilities.

- **Clean and Quiet Cab Environment**

No hydraulic lines are present in the cab or the cab module, ensuring a clean arrangement with less noise emission.





Cat MineStar System and Technology Solutions

Evolving Your Mine for Greater Safety and Productivity

Helping You Enhance Safety and Productivity Through Technology

Aimed at enhancing the productivity and profitability of your hydraulic shovel, we currently offer a combination of Cat MineStar System offerings and Cat hydraulic shovel technology solutions.



Cat MineStar System

Helping you achieve your goals for enhanced mine site safety, improved efficiency, reduced operating costs, and greater profitability, the Cat MineStar System provides the most comprehensive suite of mining technology products in the industry. It consists of a number of configurable capability sets – Fleet, Terrain, Detect, Health, and Command – that allow you to scale the system to your mine site needs. Cat MineStar System helps you manage everything from material tracking to sophisticated real-time fleet management, machine health systems, autonomous equipment, and more.

The Cat 6018/6018 FS is currently able to utilize two of the Cat MineStar System capability sets:

- **Fleet**

Fleet provides real-time machine tracking, assignment and productivity management, providing a comprehensive overview of all your asset operations from anywhere in the world.

- **Terrain**

Terrain enables high-precision management of drilling, dragline, grading and loading operations through the use of guidance technology. It increases machine productivity and provides you real-time feedback for improved efficiency.

The remaining Cat MineStar System capability sets are currently under development for the Cat hydraulic shovel product line.

Hydraulic Shovel Technology Solutions

- **Monitoring and Diagnostic System**

Enhancing diagnostic capabilities and providing detailed troubleshooting functions, our Board Control System uses sensors throughout the machine to monitor operating data, record faults, and notify the operator audibly and visually. This promotes the earliest possible detection of faults and allows for timely maintenance planning and assistance for speedy repair.



Loading/Hauling Efficiency

Move More Material with Optimal Pass Match Pairings



Achieve Targeted Loading/Hauling Production with Perfectly Paired Cat Hydraulic Shovels and Off-Highway Trucks

For full truck payloads with minimum loading time, an efficient loading/hauling system begins with an optimized equipment match. Cat hydraulic shovels are matched with Cat off-highway trucks to maximize volume of material moved at the lowest operating cost per ton.

6018/6018 FS Pass Match with Cat Off-Highway Trucks

	773G/773E	775G/775E	777G/777D
	56 tonne (62 ton)	65 tonne (72 ton)	97 tonne (107 ton)
6018/6018 FS	3	3-4	5

Rugged Front Attachment Options Designed and Fabricated to Withstand Your Extreme Mining Conditions

To extend service life and ensure that your shovel keeps producing, our front attachment structures are designed for durability and dependability. Whether you equip your hydraulic shovel in backhoe or front shovel configuration, extended performance in the harsh mining conditions you face daily is accomplished through selection of high-strength steels and rugged castings, joined and thermally stress-relieved, to help you achieve your productivity targets.

Front Attachment Structures Include:

- Heavy castings at all pivot points
- Better flow of forces and less welding seams, as top chords are made of one bend plate
- Entire boom and stick are stress relieved after welding
- Welding procedures allow for internal welding (double prep weld)



Front Attachment Options and Structures Bolstering Your Investment with Robust and Durable Structures





Swing System

Longer Component Life for Better
Swing System Reliability

More Reliable Swing Component Life

Extending component life and ultimately improving machine uptime, our swing system includes a triple-race swing roller bearing with internal gearing connected to an automatic lubrication system.

For added reliability, all lube lines are located inside the roller bearing for maximum protection.

Service Friendly

Easier maintenance is afforded by the free accessibility of swing gears and rotary distributor.

Less Wear and Tear on Crawler Components

Extending track life and improving overall machine reliability, our undercarriages are engineered with extensive use of finite element analysis, steel structures are optimized, travel motors are well-protected, and a unique robust track chain incorporates a combined pad/link design. Further extending track life, a state-of-the-art track tensioning system with membrane accumulator automatically adapts the tensioning of the tracks, depending upon operating conditions.



Undercarriage
Tough and Long-lasting

Safety

Designed with Your Safety as Our Top Priority



Sharing your commitment to safety, and driven by our commitment to Zero Harm, we work tirelessly to design safe machines to protect your most important asset; your employees.

Some examples of the safety-enhancing features of Cat hydraulic shovels include the following:

Machine Access

- Hydraulically operated boarding ladder with emergency lowering via nitrogen accumulator ensures that ladder remains operational even when engines shut off.
- Machine swing and propel capability is switched-off when ladder is in down position.

Precise Bucket Control

- Minimizing the potential for material spill on to the attachment or cab, the TriPower automatic roll-back limiter prevents the bucket from being curled back too far.

Operator Environment

- Switch in seat cushion to automatically neutralize the hydraulic controls when operator leaves the seat.
- FOPS and DIN ISO 3449 safety standards integrated into cab structure.
- Safety glass windows, armored windshield and sliding side window.

Emergency Shut-offs

- An easily accessible, standard shut-off switch located in the cab shuts down the electrical system in case of emergencies.
- Additional shut-off switches are located on the machine, in the machine house or accessible from the ground with pull ropes.

Serviceability

Designed to Get You Back to Work Fast



Lowering your operating costs and maximizing your hydraulic shovel's uptime and productivity is of supreme importance to us. To that end, we've made vital components more accessible and designed simpler systems to make maintenance activities quicker and easier.

Open, Spacious Access to Components

- Facilitating easier maintenance, exceptional accessibility is provided to systems like the swing motor, swing gearbox and rotary distributor in the well organized superstructure. The drive train is accessible from both the outside and inside of the superstructure.
- Easily accessed by walkways on both sides, the boom-mounted main valve block, a feature unique to Cat Hydraulic Shovels, provides a clean layout and reduces the number of hoses leading from the superstructure to the attachment.

Simple Hydraulic System

- Ensuring neat organization for safe operation, easy inspection and fast service, the design of our hydraulic shovel reduces the total number of required hoses. Only four high-pressure hydraulic lines are connected between the superstructure and boom on the 6018/6018 FS.

Easy Ground-level Fuel and Fluid Replenishment

- Quick fuel and fluid replenishment is made easy with a retractable service station underneath the engine module, accessible at ground-level.



Customer Support

Stay Up and Running with Service and Support from Our Unmatched Global Network

Commitment Makes the Difference

Cat dealers offer a wide range of solutions, services and products that help you lower costs, enhance productivity and manage your operation more efficiently. From the time you select a piece of Cat equipment until the day you trade or sell it, the support you get from your Cat dealer makes the difference.

Dealer Capability

Cat dealers provide the level of support you need, on a global scale. Dealer expert technicians have the knowledge, experience, training and tooling necessary to handle your repair and maintenance needs, when and where you need them.





Product Support

When Cat products reach the field, they are supported by a worldwide network of parts distribution facilities, dealer service centers and technical training facilities to keep your equipment up and running. Cat customers rely on prompt, dependable parts availability through our global dealer network, ready to meet your needs 24/7.

Service Support

Every piece of Cat equipment is designed and built to provide maximum productivity and operating economy throughout its working life. Cat dealers offer a wide range of service plans that will maximize uptime and return on your investment, including:

- Preventive Maintenance Programs
- Diagnostic Programs, such as Scheduled Oil Sampling and Technical Analysis
- Rebuild and Reman Option
- Customer Support Agreements

Application Awareness

Operating and maintenance costs are influenced by many application and site-specific factors, such as: material density and fragmentation, payload, bench height, truck positioning, ground conditions, amount of travelling and maintenance. Your Cat dealer can provide you with an understanding of the effects application characteristics and operating techniques have on maintenance and operating costs.

Operation

Your Cat dealer can arrange training programs to help operator's improve productivity, decrease downtime, reduce operating costs and enhance safety.



Meeting the needs of today while conserving natural resources for tomorrow is the goal for all Cat machinery. The commitment to helping you operate safely and sustainably is affirmed in the production of the 6018/6018 FS hydraulic shovel.

Cat Hydraulic Shovel Sustainability

- **Electric Power Option**

Reduce your carbon footprint with our lower emission electric drive option.

- **Energy Recovery**

Emit less heat and improve energy efficiency via the energy recovery capability of the closed-loop swing circuit.

- **Rebuilds**

Decrease your energy use and material consumption with a machine that's designed to be rebuilt.

Sustainability

Higher Standards for a Better Tomorrow



6018/6018 FS Hydraulic Shovel Specifications

General Data

Operating weight		
Face Shovel	183 tonnes	202 tons
Backhoe	186 tonnes	205 tons
Engine output SAE J1995		
2 × Cat C18 ACERT	858 kW	1,150 hp
Standard bucket capacity		
Face Shovel (heaped 2:1)	10.0 m ³	13.1 yd ³
Backhoe (heaped 1:1)	10.0 m ³	13.1 yd ³

Features

- Twin-engine concept
- TriPower shovel attachment
- Independent oil-cooling system
- 3-circuit hydraulic system
- Electronic-hydraulic servo control
- Board Control System (BCS)
- Torque control in closed-loop swing circuit
- Automatic central lubrication system
- Xenon working lights

Operating Weight

Shovel		
Standard track pads	800 mm	2 ft 7 in
Operating weight	183 400 kg	404,320 lb
Ground pressure	18.5 N/cm ²	26.9 psi
• Additional track pads available on request		
Backhoe		
Standard track pads	800 mm	2 ft 7 in
Operating weight	186 000 kg	410,060 lb
Ground pressure	18.6 N/cm ²	27.3 psi
• Additional track pads available on request		

Diesel Engines

Make and model	2 × Cat C18 (Tier 3)	
Total rated net power – ISO 3046/1	824 kW	1,104 hp
	1,800 min ⁻¹	1,800 min ⁻¹
Total rated net power – SAE J1349	824 kW	1,104 hp
	1,800 min ⁻¹	1,800 min ⁻¹
Total rated gross power – SAE J1995	858 kW	1,150 hp
	1,800 min ⁻¹	1,800 min ⁻¹
Number of cylinders (each engine)	6	
Bore	145 mm	5.7 in
Stroke	183 mm	7.2 in
Displacement	18.1 L	1,105 in ³
Aspiration	Turbocharged and charge air cooled	
Maximum altitude without deration at 20° C (68° F) – above sea level	2000 m	6,560 ft
Emissions	U.S. E.P.A. Flex, EU Flex	
Alternators	2 × 150A	
Fuel tank capacity	3200 L	845 gal

- Micro processed engine management
- Heavy duty air filters
- Two-stage fuel filter including water separator

Electric Motor – 6018 AC/6018 AC FS

Type	Squirrel cage induction motor
Output	650 kW
Voltage	6.3 kV ± 10% (other on request)
Rated current I _N	72A (at 6.3 kV)
Frequency	50 Hz (60 Hz on request)
Revolutions	1,500 min ⁻¹ (1,800 min ⁻¹ on request)
Starting current	350% of I _N (197% of I _N optional)

- Custom-made electric motor with increased gap between rotor and stator to withstand severe mining conditions
- Power limit control by Pump Managing System

Electrical System (diesel drive)

System voltage	24V
Batteries (12V each) in series/parallel installation	4 × 210 Ah 420 Ah – 24V
Working spotlights	8 × Xenon lights

- Battery isolation relays
- Emergency stop switches accessible from ground level and in engine module

6018/6018 FS Hydraulic Shovel Specifications

Hydraulic System with Pump Managing System

Main pumps		
Diesel version	4 × variable swash plate pumps	
AC version	2 × variable axial piston pumps	
Maximum oil flow		
Diesel version	4 × 412 L/min	4 × 109 gal/min
AC version	2 × 578 L/min	2 × 153 gal/min
Maximum pressure, attachment		
	300 bar	4,350 psi
Swing pumps		
Diesel version	2 × reversible swash plate pumps	
AC version	1 × reversible swash plate pump	
Maximum oil flow		
Diesel version	2 × 288 L/min	2 × 76 gal/min
AC version	516 L/min	136 gal/min
Maximum pressure, swing pumps		
	370 bar	5,365 psi
Total volume of hydraulic oil – approximately		
	2500 L	660 gal
Hydraulic tank capacity – approximately		
	2000 L	528 gal

- Pump Managing System contains:
 - Electronic load limit control
 - Flow on demand from main pumps depending on joystick position
 - Automatic regulation of main pumps to zero flow without demand
 - Automatic RPM reduction of engine speed during workout breaks
 - Reduced oil flow of main pumps at high hydraulic oil temperature or at low and high engine temperature
- Pressure cut-off for main pumps
- Cooling of pump transmission gear oil
- Filters:
 - Full-flow high-pressure filters (100 µm) for the main pumps, installed directly behind each pump
 - Full-flow filters (10 µm) for the complete return circuit
 - Pressure filters (40 µm and 6 µm) for servo circuit

Hydraulic Oil Cooling

Oil flow of cooling pumps		
Diesel version	2 × 412 L/min	2 × 109 gal/min
AC version	608 + 218 L/min	161 + 58 gal/min
Diameter of fans		
	2 × 1120 mm 2 × 3 ft 8 in	

- Cooling system is fully independent of all main circuits, i.e. controlled cooling capacity is available whenever engine is running
- Gear-type cooling pumps supplying high-volume low pressure oil to fans and aluminum coolers
- Fan speed and flow of oil to the coolers are electronically controlled
- Extremely high cooling efficiency to ensure optimum oil temperature

Swing System

Swing drives	2 compact planetary transmissions with axial piston motors
Parking brakes	Wet multiple disc brake, spring-loaded/hydraulically released
Maximum swing speed	
Diesel version	4.7 rpm
AC version	4.1 rpm
Swing ring	Triple race roller bearing with sealed internal gearing

- Closed-loop swing circuit with torque control
- Hydraulic braking of the swing motion by counteracting control
- All raceways of swing ring, as well as grease bath for internal gearing, supplied by automatic central lubrication system

Retractable Service Station

Retractable service station installed underneath the engine module and easily accessible from ground. Equipped with:

- Quick couplings for:
 - Diesel fuel
 - Engine coolant – left/right
 - Pump transmission gear oil – left/right
 - Engine oil – left/right
 - Hydraulic oil tank
 - Grease container (optional)
- Cat jump-start socket
- Indicator lights for fuel tanks left/right full

Operator's Cab

Operator's eye level		
Diesel version – approximately	5.4 m	17 ft 9 in
AC version – approximately	6.2 m	20 ft 4 in
Internal dimensions of cab		
Length	1800 mm	5 ft 11 in
Width	1300 mm	4 ft 3 in
Height	2150 mm	7 ft 1 in

- Pneumatically cushioned and multi-adjustable comfort seat with lumbar support, seat heating, safety belt, head- and armrests
- Switch in seat cushion to automatically neutralize the hydraulic controls when operator leaves the seat
- Joystick controls integrated in independently adjustable seat consoles
- Fold-away auxiliary seat with safety belt
- FOPS (rock guard; approved acc. to DIN ISO 3449) integrated into cab structure
- All-round safety glass, armored windshield and sliding side window
- Windshield with parallel intermittent wiper/washer
- Roller blind at windshield
- Robust instrument panel includes large colored BCS screen with transfective technology
- Board Control System (BCS) electronic monitoring and data logging system for vital signs and service data of engines, hydraulic system and lubrication system
- Machine access via retractable boarding ladder, hydraulically operated
- Emergency exit harness kit

Undercarriage

Travel speeds		
Diesel version – maximum	2.3 km/h	1.43 mph
AC version – maximum	1.7 km/h	1.06 mph
Maximum tractive force	1239 kN	278,440 lbf
Gradeability of travel drives – maximum	88%	
Track pads (each side)	47	
Bottom rollers (each side)	8	
Support rollers (each side)	2 plus a skid plate in between	
Travel drives (each side)	1 planetary transmission with 1 axial piston motor	
Parking brakes	Wet multiple disc brake, spring applied/ hydraulically released	

- Forged double-grouser track pads
- Chain links connected by hardened pins and bushings
- All running surfaces of sprockets, idlers, rollers and track links are hardened
- Fully hydraulic self-adjusting track tensioning system with membrane accumulator
- Automatic hydraulic retarder valve to prevent overspeed on downhill travel
- Acoustic travel alarm
- Track guides

Automatic Lubrication System

Capacity of grease barrel 200 L 53 gal

- Dual-circuit system with hydraulically driven heavy-duty pump and electronic time relay control to adjust the pause/lube times
- Connected to the lubrication system are the swing roller bearing with internal gearing and all pivot points of attachment, bucket and cylinders except linkage of BH attachment
- System failures displayed by Board Control System
- Grease filters (200 µm) behind grease pump

Attachments

- Booms and sticks are torsion-resistant, welded box design of high tensile steel with massive steel castings at pivot areas
- Welding procedures allow for internal counter-welding (double prep weld) wherever possible
- Booms and sticks are stress-relieved after welding
- Inspection hole in boom (FS)
- Pressure-free lowering of boom (FS and BH) and stick (FS) by means of a float valve
- Shovel attachment with unique TriPower kinematics ensuring the following main features:
 - Horizontal automatic constant-angle bucket guidance
 - Vertical automatic constant-angle bucket guidance
 - Automatic roll-back limiter to prevent material spillage
 - Kinematic assistance to hydraulic forces
 - Constant boom momentum throughout the whole lift arc
 - Crowd force assistance
- All buckets (FS and BH) are equipped with a wear package consisting of:
 - Special liner material covering main wear areas inside and outside of bucket
 - Lip shrouds between teeth
 - Wing shrouds on side walls
 - Bottom edge protection
- Special wear packages for highly abrasive materials on request

6018/6018 FS Hydraulic Shovel Specifications

Dimensions

All dimensions are approximate.

Dimensions and weights of AC machine differs slightly. Separate drawings, dimensions and weights can be provided upon request.

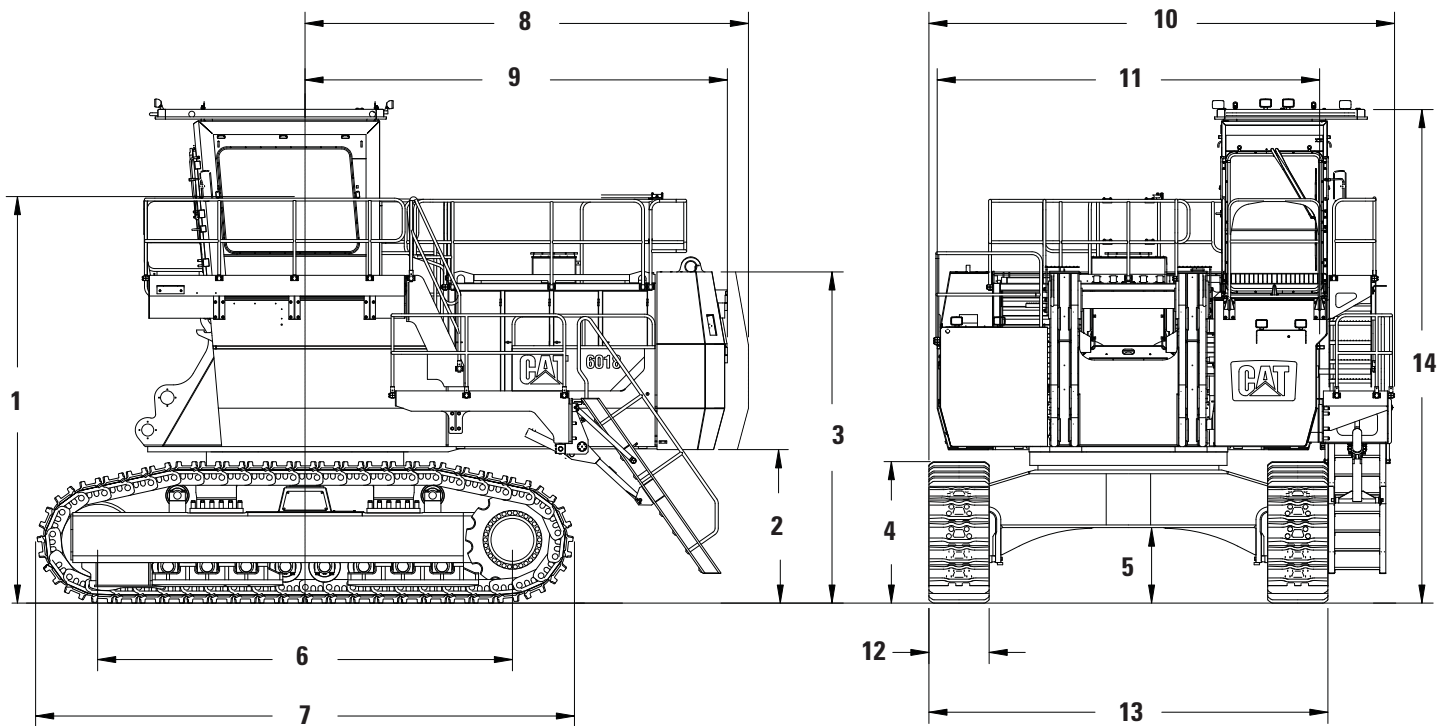

1	5400 mm	17 ft 9 in	8	5890 mm	19 ft 4 in
2	2040 mm	6 ft 8 in	9	5610 mm	18 ft 5 in
3	4400 mm	14 ft 5 in	10	6190 mm	20 ft 4 in
4	1880 mm	6 ft 2 in	11	5080 mm	16 ft 8 in
5	1000 mm	3 ft 3 in	12	800 mm	2 ft 7 in
6	5500 mm	18 ft 1 in	13	5300 mm	17 ft 5 in
7	7120 mm	23 ft 4 in	14	6560 mm	21 ft 6 in

Working Range – TriPower Face Shovel Attachment (FS)

All dimensions are approximate.

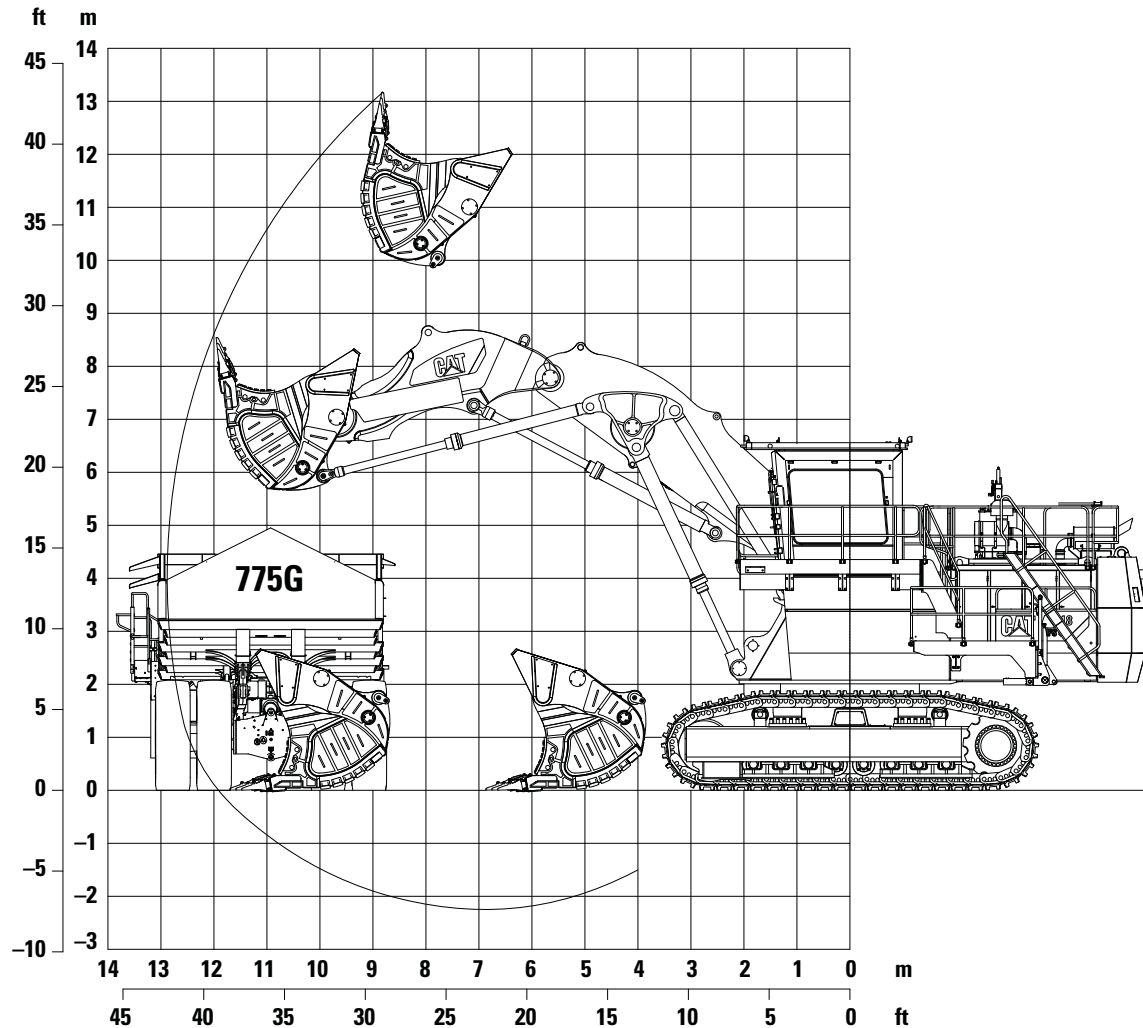

Boom	6.35 m	20 ft 10 in	Working Range	
Stick	4.1 m	13 ft 5 in	Maximum digging height	13.2 m 43 ft 4 in
Digging Forces			Maximum digging reach	12.9 m 42 ft 4 in
Maximum crowd force	910 kN	204,500 lbf	Maximum digging depth	2.3 m 7 ft 7 in
Maximum crowd force at ground level	810 kN	182,030 lbf	Maximum dumping height	10.1 m 33 ft 2 in
Maximum breakout force	730 kN	164,050 lbf	Crowd distance on level	4.8 m 15 ft 9 in

Face Shovels

Type	Heavy Rock Shovel		Standard Rock Shovel	
Capacity heaped 1:1	9.4 m ³	12.3 yd ³	11.4 m ³	14.9 yd ³
Capacity heaped 2:1	8.0 m³	10.5 yd³	10.0 m³	13.1 yd³
Total width	3750 mm	12 ft 4 in	3750 mm	12 ft 4 in
Inner width	3330 mm	10 ft 11 in	3330 mm	10 ft 11 in
Opening width	1900 mm	6 ft 3 in	1900 mm	6 ft 3 in
Number of teeth	5		5	
Weight including wear package	16 450 kg	36,270 lb	17 650 kg	38,910 lb
Maximum material density (loose)	2.2 t/m ³	3,710 lb/yd ³	1.8 t/m ³	3,030 lb/yd ³

6018/6018 FS Hydraulic Shovel Specifications

Working Range – Backhoe Attachment (BH)

All dimensions are approximate.

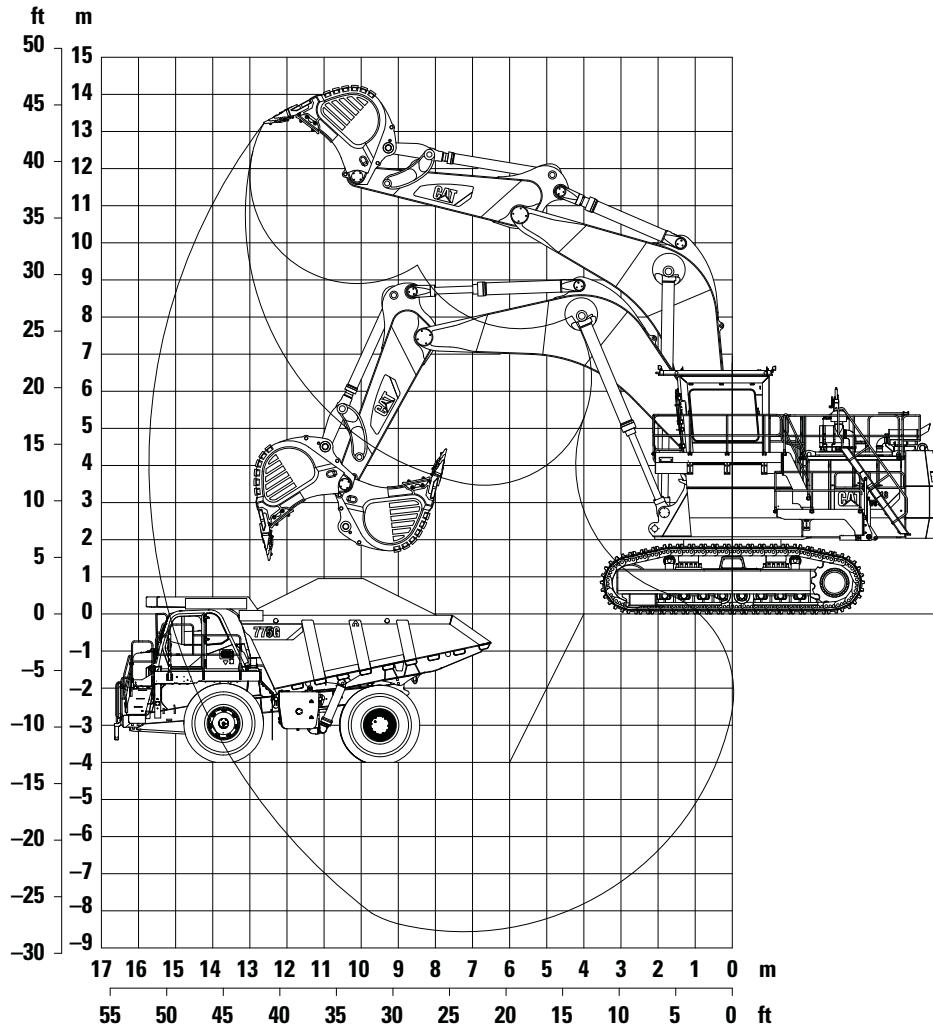

Boom	8.5 m	27 ft 11 in
Stick	4.5 m	14 ft 9 in
Digging Forces		
Maximum tearout force	540 kN	121,350 lbf
Maximum breakout force	510 kN	114,610 lbf

Working Range			
Maximum digging depth	8.5 m	27 ft 11 in	
Maximum digging reach	15.6 m	51 ft 2 in	
Maximum digging height	13.2 m	43 ft 4 in	

Backhoes

Type	Iron Ore Bucket		Heavy Rock Bucket		Standard Rock Bucket	
Capacity heaped 1:1	7.5 m³	9.8 yd³	8.5 m³	11.1 yd³	10.0 m³	13.1 yd³
Capacity heaped 2:1	6.6 m ³	8.6 yd ³	7.6 m ³	9.9 yd ³	9.0 m ³	11.8 yd ³
Capacity struck	6.0 m ³	7.8 yd ³	6.7 m ³	8.8 yd ³	8.0 m ³	10.5 yd ³
Total width	2290 mm	7 ft 6 in	2890 mm	9 ft 6 in	2960 mm	9 ft 9 in
Inner width	1900 mm	6 ft 3 in	2513 mm	8 ft 3 in	2570 mm	8 ft 5 in
Number of teeth	4		5		5	
Weight including wear package	8850 kg	19,510 lb	10 350 kg	22,820 lb	11 300 kg	24,910 lb
Maximum material density (loose)	2.6 t/m ³	4,380 lb/yd ³	2.2 t/m ³	3,710 lb/yd ³	1.8 t/m ³	3,030 lb/yd ³

General Packing List

Crawler side frame with track pads (2 units, each)

Gross weight	24 100 kg (53,130 lb)
1 Length	7150 mm (23 ft 5 in)
Width	950 mm (3 ft 1 in)
2 Height	1900 mm (6 ft 3 in)

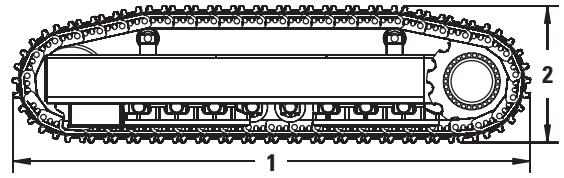

Undercarriage center frame with swing roller bearing

Gross weight	14 200 kg (31,310 lb)
1 Length	5150 mm (16 ft 11 in)
Width	3050 mm (10 ft 1 in)
2 Height	1600 mm (5 ft 3 in)

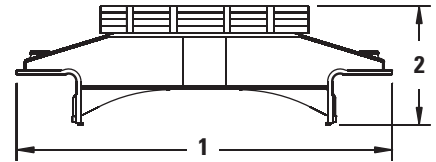

Superstructure center frame

Gross weight	18 800 kg (41,450 lb)
1 Length	7530 mm (24 ft 1 in)
Width	2650 mm (8 ft 8 in)
2 Height	2650 mm (8 ft 8 in)

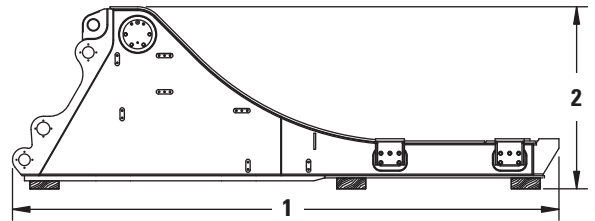

Engine module with diesel engines

Gross weight	16 200 kg (35,710 lb)
1 Length	3100 mm (10 ft 2 in)
Width	5100 mm (16 ft 9 in)
2 Height	2900 mm (10 ft 2 in)

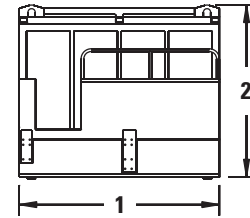

Oil cooler module

Gross weight	2130 kg (4,700 lb)
1 Length	3000 mm (9 ft 10 in)
Width	1550 mm (5 ft 1 in)
2 Height	1650 mm (5 ft 5 in)

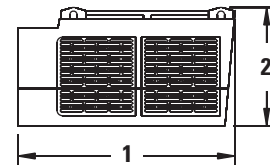

Above values are approximate. Details may vary depending on scope of supply and destination. Exact data subject to selected machine configuration and final packing list.

6018/6018 FS Hydraulic Shovel Specifications

General Packing List

Cab pedestal module

Gross weight	3390 kg (7,470 lb)
1 Length	3320 mm (10 ft 11 in)
Width	1800 mm (5 ft 11 in)
2 Height	2300 mm (7 ft 7 in)

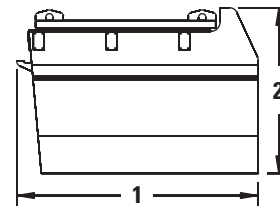

Crate with cabin and FOPS

Gross weight	3500 kg (7,720 lb)
1 Length	3450 mm (11 ft 4 in)
Width	2350 mm (7 ft 9 in)
2 Height	2900 mm (10 ft 2 in)

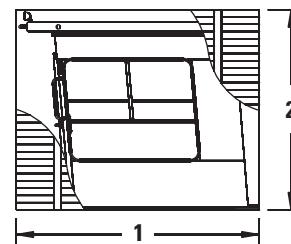

Counterweight

Gross weight	24 000 kg (52,910 lb)
1 Length	950 mm (3 ft 1 in)
Width	5100 mm (16 ft 9 in)
2 Height	2600 mm (8 ft 6 in)

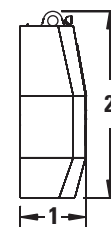

Crates

Content	1 Length	Width	2 Height	Gross Weight
Two swing gears	1650 mm (5 ft 5 in)	1100 mm (3 ft 7 in)	1750 mm (5 ft 9 in)	1440 kg (3,170 lb)
Swing ring bolts, covers, tools, etc.	3400 mm (11 ft 2 in)	1250 mm (4 ft 1 in)	1450 mm (4 ft 9 in)	1610 kg (3,550 lb)
Handrails, catwalks, air filters, etc.	4500 mm (14 ft 9 in)	1900 mm (6 ft 3 in)	1800 mm (5 ft 11 in)	2500 kg (5,510 lb)
Grease container with pump	1400 mm (4 ft 7 in)	1100 mm (3 ft 7 in)	2050 mm (6 ft 9 in)	670 kg (1,480 lb)
Barrels with hydraulic oil and grease	1900 mm (6 ft 3 in)	1300 mm (4 ft 3 in)	1250 mm (4 ft 1 in)	1400 kg (3,090 lb)
Air condenser	1450 mm (4 ft 9 in)	1050 mm (3 ft 5 in)	1200 mm (3 ft 11 in)	280 kg (620 lb)
Pallet with retractable ladder	4000 mm (13 ft 1 in)	1000 mm (3 ft 3 in)	1900 mm (6 ft 3 in)	740 kg (1,630 lb)

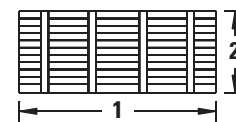

Above values are approximate. Details may vary depending on scope of supply and destination. Exact data subject to selected machine configuration and final packing list.

TriPower Shovel Attachment

Boom with main valve block, TriPower linkages and rods

Gross weight	17 100 kg (37,700 lb)
1 Length	7050 mm (23 ft 2 in)
Width	2150 mm (7 ft 1 in)
2 Height	2800 mm (9 ft 2 in)

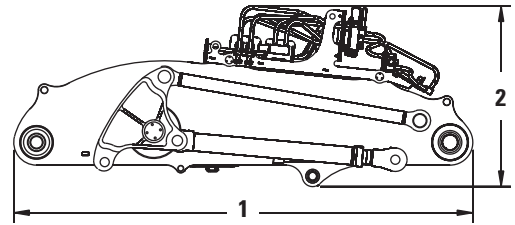

Stick including pin for boom

Gross weight	6200 kg (13,670 lb)
1 Length	4750 mm (15 ft 7 in)
Width	1650 mm (5 ft 5 in)
2 Height	1900 mm (6 ft 3 in)

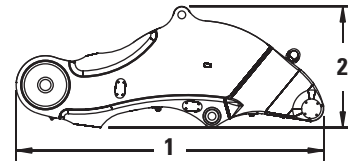

Face shovel including pin for stick

Capacity (2:1)	10.0 m ³ (13.1 yd ³)
Gross weight	18 000 kg (39,680 lb)
1 Length	3350 mm (11 ft)
Width	3750 mm (12 ft 4 in)
2 Height	2900 mm (9 ft 6 in)

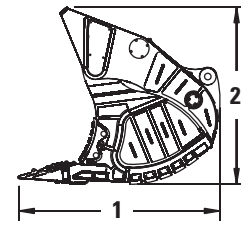

Crate with two bucket cylinders

Gross weight	2100 kg (4,630 lb)
1 Length	3600 mm (11 ft 10 in)
Width	1000 mm (3 ft 3 in)
2 Height	1000 mm (3 ft 3 in)

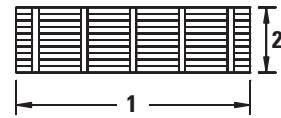

Crate with two stick cylinders

Gross weight	2200 kg (4,850 lb)
1 Length	3600 mm (11 ft 10 in)
Width	900 mm (2 ft 11 in)
2 Height	850 mm (2 ft 9 in)

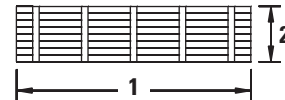

Above values are approximate. Details may vary depending on scope of supply and destination. Exact data subject to selected machine configuration and final packing list.

6018/6018 FS Hydraulic Shovel Specifications

Backhoe Attachment

Monoboom with main valve block, boom and stick cylinders

Gross weight	25 800 kg (56,880 lb)
1 Length	9000 mm (29 ft 6 in)
Width	2200 mm (7 ft 3 in)
2 Height	3550 mm (11 ft 8 in)

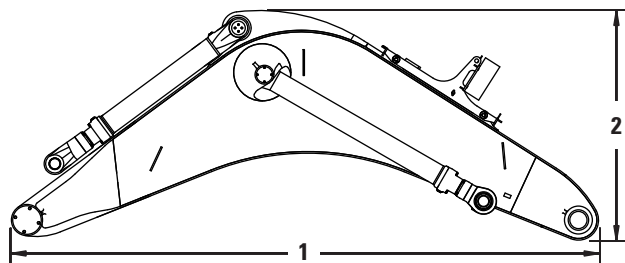

Stick with linkage and bucket cylinder

Gross weight	10 000 kg (22,050 lb)
1 Length	6000 mm (19 ft 8 in)
Width	1400 mm (4 ft 7 in)
2 Height	2050 mm (6 ft 9 in)

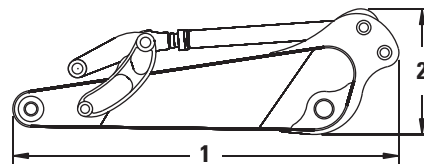

Backhoe bucket including pins for stick and linkage

Capacity (1:1)	8.5 m ³ (11.1 yd ³)	10.0 m ³ (13.1 yd ³)
Gross weight	10 750 kg (23,700 lb)	11 700 kg (25,790 lb)
1 Length	3400 mm (11 ft 2 in)	3400 mm (11 ft 2 in)
Width	2900 mm (9 ft 6 in)	3000 mm (9 ft 10 in)
2 Height	2500 mm (8 ft 2 in)	2750 mm (9 ft)

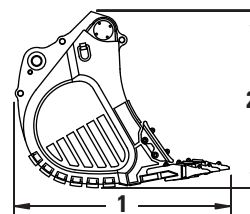

Above values are approximate. Details may vary depending on scope of supply and destination. Exact data subject to selected machine configuration and final packing list.

Optional Equipment

Optional equipment may vary. Consult your Cat dealer for details.

GENERAL

- Export crating
- Finishing as per end user's corporate colors

SUPERSTRUCTURE

- Camera system
- High capacity water separator
- Various cold-weather packages

CAB

- Various heating and air-conditioning systems
- Roller blinds at all windows
- Additional instrumentation

UNDERCARRIAGE

- Track pad width 600 mm (2 ft)
- Belly plate

ATTACHMENT

- Guards for boom cylinders of FS attachment
- Xenon lighting on boom
- Special wear packages

Additional optional equipment available on request.

For more complete information on Cat products, dealer services, and industry solutions, visit us on the web at www.cat.com

© 2013 Caterpillar Inc.
All rights reserved

Materials and specifications are subject to change without notice. Featured machines in photos may include additional equipment. See your Cat dealer for available options.

CAT, CATERPILLAR, SAFETY.CAT.COM, their respective logos, "Caterpillar Yellow" and the "Power Edge" trade dress, as well as corporate and product identity used herein, are trademarks of Caterpillar and may not be used without permission.

AEHQ6968-01 (08-2013)
Replaces AEHQ6968

