

6030/6030 FS

Hydraulic Shovel



Engine*

Engine Model	2 × Cat® C27 ACERT™	
Gross Power – SAE J1995	1140 kW	1,530 hp
Net Power – SAE J1349	1140 kW	1,530 hp

*Electric drive option available (1000 kW) on 6030 AC/6030 AC FS

Bucket

Bucket Capacity – Front Shovel (heaped 2:1)	16.5 m ³	21.6 yd ³
Bucket Capacity – Backhoe (heaped 1:1)	17.0 m ³	22.0 yd ³

Operating Specifications

Bucket Payload	30 tonnes	34 tons
Operating Weight – Front Shovel	294 tonnes	324 tons
Operating Weight – Backhoe	296 tonnes	326 tons

6030/6030 FS Features

With over 250 deliveries world-wide, the Cat 6030/6030 FS is our most popular and best-selling hydraulic mining shovel model. Along with the same advanced technology available on its larger Cat counterparts, the 6030/6030 FS provides the most powerful engine output in its class for added productivity and facilitates the mobility and flexibility you need from a 300 tonne machine. When optimally paired with our 777 or 785 Series mining trucks, you'll experience the operational efficiency and productivity you're looking for, supported by our unmatched Cat dealer network.

Contents

Drive Systems.....	4
Twin-engine Concept.....	5
TriPower System (Front Shovel Machines)....	6
Hydraulic System.....	8
Independent Oil Cooling System.....	9
Pump Managing System.....	10
Closed-loop Swing Circuit.....	11
Operator's Cab.....	12
Electronic Control System.....	13
Cat MineStar™ System and Technology Solutions.....	14
Loading/Hauling Efficiency.....	16
Front Attachment Options and Structures....	17
Swing System.....	18
Undercarriage.....	19
Safety.....	20
Customer Support.....	21
Serviceability.....	22
Sustainability.....	23
Specifications.....	24
Optional Equipment.....	35





Every Day Matters, Every Load Counts

We understand the challenges you face, the importance of reliability, and the relationship between uptime and productivity. That's why we continually strive to produce the safest, most reliable and productive hydraulic shovels possible. Offering the widest payload range of any manufacturer in the industry, the ability to optimally pair with our popular line of mining trucks, and the support of our world-class Cat dealer network, we are uniquely positioned to partner with you to help achieve your productivity targets. We understand what matters to you. Our hydraulic shovels are built with you in mind. Because in mining, every day matters and every load counts.

Drive Systems

Balanced Combination of Power and Efficiency



Meeting Your Site Specific Needs with a Choice of Robust Drive System Options

Giving you the option to choose the drive system best suited for your operation, the Cat 6030/6030 FS can be equipped with either two Cat C27 diesel engines for greater mobility, or an electric drive for better efficiency.

- **Reliable Cat C27 ACERT Engine**

Delivering durable, reliable power that will keep your primary loading tool producing, the C27 is one of the most widely used engines in the mining industry, proving its ability to stand-up to the harshest conditions while providing the mobility and flexibility you desire.

Boosting your productivity, the C27 equipped Cat 6030/6030 FS offers the most powerful engine output in its size class.

- **Efficient Electric Drive System on 6030 AC/6030 AC FS**

Providing a lower cost-per-ton alternative to diesel powered hydraulic shovels, our electric drive option maintains the ruggedness you need and offers superior availability since no refueling and less service is required.

The 6030 AC/6030 AC FS is the ideal solution for operations that do not require a great deal of mobility and value a low cost-per-ton model.



Twin-engine Concept

Stay Up and Running More Consistently

Keep Producing and Ensure the Safety of Your Operators, Even During Single Engine Loss

You will realize enhanced safety, greater uptime, more productivity, and better serviceability as a result of our twin-engine concept.

- **Enhanced Safety**

The ability to move your shovel to a safe area for repair, away from high walls, blast zones, or other safety hazards, is still possible with the use of a single engine.

- **Greater Uptime and More Productivity**

Up to 65% of full production can still be achieved with the use of a single engine. This is due to the shovel's continued ability to exert maximum digging forces, to lower the front attachment without requiring engine power (i.e., pressure-free), and to recuperate energy via its closed-loop swing circuit.

- **Better Serviceability**

Troubleshooting is greatly simplified and expedited with the ability to compare one engine versus the other.

TriPower System (Front Shovel Machines)

Superior Digging Capability and Bucket Fill Factors



Dig More Effectively with Our Unique TriPower Front Shovel Design

You will experience enhanced, easier and faster front shovel operation with TriPower, a system proven on over a thousand Cat hydraulic shovels worldwide. Generating superior mechanical leverage and control, our FS configured hydraulic shovels utilize a unique boom design that employs rotatable triangular rockers. This design facilitates quicker cycle times, increased effective lifting force, constant boom momentum, automatic constant bucket angle, and automatic roll-back limiter.



- **Quicker Cycle Times**

- Faster lifting speeds are achieved, because the design enables the use of smaller-diameter boom cylinders.

- **Increased Effective Lifting Force**

- Design transfers digging forces into the superstructure, creating supporting boom momentum in addition to momentum that is generated hydraulically.

- **Constant Boom Momentum**

- Allows smaller boom cylinders for higher lifting speed.
- Keeps lifting speed constant.
- Enables the shovel to lift a single load along the entire digging distance.
- No retracting of stick cylinders is required, ensuring that all hydraulic pumps are supplying the boom-up function.

- **Automatic Constant Bucket Angle**

- Material spillage is avoided during boom lifting, because the filled bucket automatically maintains a constant bucket angle.
- On conventional kinematics the operator has to control manually the bucket position during lifting which cut in half the available oil flow for the boom cylinders.

- **Automatic Roll-back Limiter**

- Preventing material spillage back on to the operator's cab and machine superstructure, our system ensures that the bucket is always in a safe position, without operator control/manipulation, when it is at maximum height.
- The boom cylinder continues to receive maximum oil flow, because the operator does not need to activate the bucket cylinder.





Hydraulic System

Easy Serviceability and Greater Productivity

Straightforward, Safe System Maintenance

Ensuring neat organization for safe operation, easy inspection, and fast service, and reducing the number of hoses needed, the main valve block is located on top of the boom.

Faster Cycle Times

Faster cycle times are realized, because float valves are used to lower the boom instead of engaging pumps. This facilitates faster boom movements and allows other operating functions to occur simultaneously, such as bucket curl and stick in/out.

Greater Control

Your operators will experience greater control with our five circuit hydraulics, allowing for two cylinder motions, two travel motions, and swing to be controlled simultaneously.

Protect and Extend the Life of Your Hydraulic Components

Providing a more efficient means of cooling, particularly in demanding applications, our unique independent oil cooling system will extend the life of your hydraulic shovel's components.

More Efficient Oil Cooling

Our system is independent of return oil, achieving efficiency through the utilization of dedicated pumps that provide cooling capacity as needed, whether the engine is idling or under load. That means optimum oil temperature is being maintained, even while your operator waits for the next truck to load. Competitive hydraulic shovels only provide cooling when the machine is working and the engine is under load.

Additional efficiency is achieved via our thermostatically controlled radiator fan speed. The fans do not run until oil temperature exceeds a temperature of 50° C (122° F), saving energy.

Optimal Oil Temperature Maintained

The high-efficient oil cooling system ensures that the oil temperature is only 25° to 30° C (45° to 54° F) higher than the ambient temperature. Thus, the hydraulic oil's working temperature remains within the optimal operating viscosity range of 50° to 70° C (122° to 158° F).



Experience Improved Machine Control and Component Life, while Reducing Fuel Consumption and Noise Emission, with Our Intelligent Pump Managing System

Delivering optimal performance, our pump managing system continuously evaluates actual engine and hydraulic operating values against set values, and adjusts pump output accordingly. This results in efficient use of the engine for greater productivity.

Pump managing system advantages include:

- Best possible utilization of engine output and engine overload avoidance via electronic load limit regulation
- Less energy consumption and less thermal load on hydraulic oil with zero oil flow regulation for main pumps
- Less fuel consumption and lower noise emission via automatic RPM reduction
- Reduced component wear and lower noise emission with automatic oil flow reduction for closing/opening of bucket clam
- Protection of components with automatic oil flow reduction if hydraulic and/or engine coolant temperature exceed set maximum
- Improved operator control response via on-demand pump flow

Pump Managing System

Enhanced Efficiency, Component Life,
and Control Response



Closed-loop Swing Circuit

More Efficient Energy Use and
Faster Boom Lift Motion During Swing



Load More Material, at Lower Cost, with the Energy Recovery Capability of Our Closed-loop Swing System

Delivering faster cycle times and improved energy efficiency, while also generating less heat, our closed-loop swing circuit provides distinct advantages over competitive machines utilizing open-circuit swing systems.

Greater Efficiency via Energy Recovery

Kinetic energy captured during the swing motion is fed back into the system during deceleration, providing more power to drive the main and auxiliary pumps. Energy is saved during deceleration, because braking occurs via counteracting controls, as opposed to throttles used in open circuit swing systems.

Energy Savings During Acceleration

Energy is saved during acceleration via torque control, providing a pressure balance valve that controls the swing pump against pressure in the closed-loop swing circuit, ensuring that only the minimum necessary oil flow is utilized at any given time.

Faster Cycle Times

Faster boom lift motion during swing is achieved with our closed-loop swing system, increasing overall productivity.

Operator's Cab

Ensuring the Safety and Comfort of Your Operators



Get Peak Operator Performance with Our Safe and Comfortable Operator's Cab

We understand that the most important factor in your hydraulic shovel's effectiveness is the performance of its operator. To help make their workday as productive as possible, we've incorporated safety and comfort features into the 6030/6030 FS operator's cab.

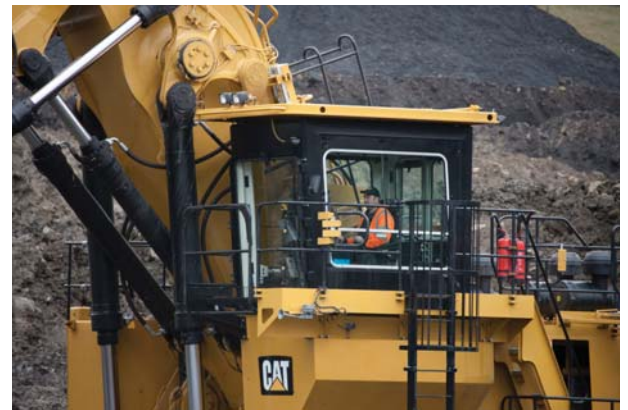

Protection for Your Operator; Every Day, Every Shift

- Safety glass is used for all cab windows, and armored glass for the windshield.
- Operator's seat is equipped with integrated safety switch that automatically neutralizes the hydraulic controls when the operator leaves the seat.
- The height of the cab module ensures an eye level of approximately 6.5 m (21 ft 4 in), providing excellent visibility of the digging and loading areas.
- Cab meets Falling Object Protection System (FOPS) and DIN ISO 3449 standards.

Supporting Peak Operator Performance with Comfort Features

- Pneumatically cushioned, multi-adjustable operator's seat.
- Large, transfective color touch-screen display (BCS III) provides vital machine monitoring and diagnostic data for convenient troubleshooting and service assistance.



Electronic Control System

Operate with Confidence

Enhanced Control Response and Optimized Hydraulic Engine Load Management

Help your team meet productivity and performance standards with our intuitive, informative on-board electronics.

Electro-Hydraulic Servo Control

- **Enhanced Control Response**

The system relays actuating signals from the joysticks, delivering fast and precise machine reactions facilitate a reduction in operator fatigue.

- **Increased Uptime**

Uptime is increased as a result of simplified troubleshooting and advanced diagnostic capabilities.

- **Greater Operator Comfort**

Easier setting of servo control characteristics allow operators to adjust to their preference.

- **Clean and Quiet Cab Environment**

No hydraulic lines are present in the cab or the cab module, ensuring a clean arrangement with less noise emission.

Control and Monitoring Platform (CAMP)

- **Reduced Control System Inventory**

Streamlined system requires only one type of controller for each function (i.e., left side drive train, right side drive train, servo, and auxiliary) reducing the number of required controllers in the system and associated replacement stock.

- **Less Fuel Consumption**

Engine works in optimal range of performance during the entire digging cycle, reducing fuel burn.

- **Increased Component Life**

Reduced hydraulic pulsation lessens stress imposed on the engine and hydraulic components.

- **Enhanced Operator Comfort**

Less vibration and more even machine movement via reduced pressure peaks.

- **On-screen Documentation**

Parts book, Technical and Operating handbook, as well as hydraulic and electric schematics are available in electronic format.



Cat MineStar System and Technology Solutions

Evolving Your Mine for Greater Safety and Productivity

Helping You Enhance Safety and Productivity Through Technology

Aimed at enhancing the productivity and profitability of your hydraulic shovel, we currently offer a combination of Cat MineStar System offerings and Cat hydraulic shovel technology solutions.



Cat MineStar System

Helping you achieve your goals for enhanced mine site safety, improved efficiency, reduced operating costs, and greater profitability, the Cat MineStar System provides the most comprehensive suite of mining technology products in the industry. It consists of a number of configurable capability sets – Fleet, Terrain, Detect, Health, and Command – that allow you to scale the system to your mine site needs. Cat MineStar System helps you manage everything from material tracking to sophisticated real-time fleet management, machine health systems, autonomous equipment, and more.

The Cat 6030/6030 FS is currently able to utilize two of the Cat MineStar System capability sets:

- **Fleet**

Fleet provides real-time machine tracking, assignment and productivity management, providing a comprehensive overview of all your asset operations from anywhere in the world.

- **Terrain**

Terrain enables high-precision management of drilling, dragline, grading and loading operations through the use of guidance technology. It increases machine productivity and provides you real-time feedback for improved efficiency.

The remaining Cat MineStar System capability sets are currently under development for the Cat hydraulic shovel product line.

Hydraulic Shovel Technology Solutions

- **Monitoring and Diagnostic System**

Enhancing diagnostic capabilities and providing detailed troubleshooting functions, our Board Control System uses sensors throughout the machine to monitor operating data, record faults, and notify the operator audibly and visually. This promotes the earliest possible detection of faults and allows for timely maintenance planning and assistance for speedy repair.



Loading/Hauling Efficiency

Move More Material with Optimal Pass Match Pairings



Achieve Targeted Loading/Hauling Production with Perfectly Paired Cat Hydraulic Shovels and Mining Trucks

For full truck payloads with minimum loading time, an efficient loading/hauling system begins with an optimized equipment match. Cat hydraulic shovels are matched with Cat mining trucks to maximize volume of material moved at the lowest operating cost per ton.

6030/6030 FS Pass Match with Cat Mining Trucks

	777G/777D	785D/785C	789D
	97 tonne (107 ton)	136 tonne (150 ton)	181 tonne (200 ton)
6030/6030 FS	3-4	4-5	6

6030/6030 FS Pass Match with Unit Rig™ Mining Trucks

	MT3300 AC	MT3700 AC
	136 tonne (150 ton)	186 tonne (205 ton)
6030/6030 FS	4-5	6



Rugged Front Attachment Options Designed and Fabricated to Withstand Your Extreme Mining Conditions

To extend service life and ensure that your shovel keeps producing, our front attachment structures are designed for durability and dependability. Whether you equip your hydraulic shovel in backhoe or front shovel configuration, extended performance in the harsh mining conditions you face daily is accomplished through selection of high-strength steels and rugged castings, joined and thermally stress-relieved, to help you achieve your productivity targets.

Front Attachment Structures Include:

- Heavy castings at all pivot points
- Better flow of forces and less welding seams, as top chords are made of one bend plate
- Entire boom and stick are stress relieved after welding
- Welding procedures allow for internal welding (double prep weld)



Front Attachment Options and Structures Bolstering Your Investment with Robust and Durable Structures





Swing System

Longer Component Life for Better
Swing System Reliability

More Reliable Swing Component Life

Extending component life and ultimately improving machine uptime, our swing system includes a triple-race swing roller bearing with internal gearing connected to an automatic lubrication system.

For added reliability, all lube lines are located inside the roller bearing for maximum protection.

Powerful Productivity

For maximum swing power and faster cycle times, the 6030/6030 FS utilizes the same swing gears as its larger Cat counterparts.

Service Friendly

Easier maintenance is afforded by the free accessibility of swing gears and rotary distributor.

Less Wear and Tear on Crawler Components

Extending track life and improving overall machine reliability, our undercarriages are engineered with extensive use of finite element analysis, steel structures are optimized, travel motors are well-protected by strong cover plates and hinged door covers, and a unique robust track chain incorporates a combined pad/link design. Further extending track life, a state-of-the-art track tensioning system with membrane accumulator automatically adapts the tensioning of the tracks, depending upon operating conditions.



Undercarriage
Tough and Long-lasting

Safety

Designed with Your Safety as Our Top Priority

Sharing your commitment to safety, and driven by our commitment to Zero Harm, we work tirelessly to design the safest machines possible to protect your most important asset; your employees.

Machine Access

- Hydraulically operated boarding ladder with emergency lowering via nitrogen accumulator ensures that ladder remains operational even when engines shut off.
- Machine swing and propel capability is switched-off when ladder is in down position.

Precise Bucket Control

- The TriPower automatic roll-back limiter prevents the bucket from being curled back too far.

Operator Environment

- Switch in seat cushion to automatically neutralize the hydraulic controls when operator leaves the seat.
- Safety glass windows, armored windshield and sliding side window.

Emergency Shut-offs

- An easily accessible, standard shut-off switch located in the cab shuts down the electrical system in case of emergencies.
- Additional shut-off switches are located on the machine, in the machine house or accessible from the ground.

Controlled Propel

- Prevention of over-speed on downhill travel provided by an automatic hydraulic retarder valve.





Customer Support

Stay Up and Running with Service and Support from Our Unmatched Global Network

Commitment Makes the Difference

Cat dealers offer a wide range of solutions, services and products that help you lower costs, enhance productivity and manage your operation more efficiently. From the time you select a piece of Cat equipment until the day you trade or sell it, the support you get from your Cat dealer makes the difference.

Dealer Capability

Cat dealers provide the level of support you need, on a global scale. Dealer expert technicians have the knowledge, experience, training and tooling necessary to handle your repair and maintenance needs, when and where you need them.

Product Support

When Cat products reach the field, they are supported by a worldwide network of parts distribution facilities, dealer service centers and technical training facilities to keep your equipment up and running. Cat customers rely on prompt, dependable parts availability through our global dealer network, ready to meet your needs 24/7.

Service Support

Every piece of Cat equipment is designed and built to provide maximum productivity and operating economy throughout its working life. Cat dealers offer a wide range of service plans that will maximize uptime and return on your investment, including:

- Preventive Maintenance Programs
- Diagnostic Programs, such as Scheduled Oil Sampling and Technical Analysis
- Rebuild and Reman Option
- Customer Support Agreements

Application Awareness

Operating and maintenance costs are influenced by many application and site-specific factors, such as: material density and fragmentation, payload, bench height, truck positioning, ground conditions, amount of traveling and maintenance. Your Cat dealer can provide you with an understanding of the effects application characteristics and operating techniques have on maintenance and operating costs.

Operation

Your Cat dealer can arrange training programs to help operator's improve productivity, decrease downtime, reduce operating costs and enhance safety.

Serviceability

Designed to Get You Back to Work Fast



Lowering your operating costs and maximizing your hydraulic shovel's uptime and productivity is of supreme importance to us. To that end, we've made vital components more accessible and designed simpler systems to make maintenance activities quicker and easier.

Open, Spacious Access to Components

- Facilitating easier maintenance, exceptional accessibility is provided to systems like the swing motor, swing gearbox and rotary distributor in the well organized superstructure.
- Easily accessed by walkways on both sides, the boom-mounted main valve block, a feature unique to Cat Hydraulic Shovels, provides a clean layout and reduces the number of hoses leading from the superstructure to the attachment.

Simple Hydraulic System

- Ensuring neat organization for safe operation, easy inspection and fast service, the design of our hydraulic shovel reduces the total number of required hoses.

Easy Ground-level Fuel and Fluid Replenishment

- Quick fuel and fluid replenishment is made easy with a retractable service station underneath the engine module, accessible at ground-level.

Improved Drive Train Troubleshooting

- Twin-engine design facilitates troubleshooting of drive trains, as one engine can be compared to the other.



Sustainability

Higher Standards for a Better Tomorrow

Meeting the needs of today without compromising the needs of tomorrow is the goal for all Cat machinery. The commitment to helping you operate safely and sustainably is affirmed in the production of the 6030/6030 FS hydraulic shovel.

Cat Hydraulic Shovel Sustainability

- **Electric Power Option**

Reduce your carbon footprint with our lower emission electric drive option.

- **Energy Recovery**

Emit less heat and improve energy efficiency via the energy recovery capability of the closed-loop swing circuit.

- **Rebuilds**

Decrease your energy use and material consumption with a machine that's designed to be rebuilt.

6030/6030 FS Hydraulic Shovel Specifications

General Data

Operating weight		
Face Shovel	294 tonnes	324 tons
Backhoe	296 tonnes	326 tons
Engine output SAE J1995		
2 × Cat C27 ACERT	1140 kW	1,530 hp
Standard bucket capacity		
Face Shovel (heaped 2:1)	16.5 m ³	21.6 yd ³
Backhoe (heaped 1:1)	17.0 m ³	22.2 yd ³

Features

- TriPower shovel attachment
- Independent oil cooling system
- Spacious walk-through machine house
- 5-circuit hydraulic system
- On-board electronics system: Control and Monitoring Platform (CAMP)
- Board Control System (BCS III)
- Torque control in closed-loop swing circuit
- Automatic central lubrication system
- Xenon working lights

Operating Weight

Face Shovel		
Standard track pads	1000 mm	3 ft 3 in
Operating weight	293 800 kg	647,710 lb
Ground pressure	22.0 N/cm ²	31.9 psi
• Additional track pads available on request		
Backhoe		
Standard track pads	1000 mm	3 ft 3 in
Operating weight	296 000 kg	652,560 lb
Ground pressure	22.1 N/cm ²	32.1 psi
• Additional track pads available on request		

Diesel Engines

Make and model	2 × Cat C27 (U.S. EPA Tier 2)	
Total rated net power – ISO 3046/1	1140 kW 1,800 min ⁻¹	1,530 hp 1,800 min ⁻¹
Total rated net power – SAE J1349	1140 kW 1,800 min ⁻¹	1,530 hp 1,800 min ⁻¹
Total rated gross power – SAE J1995	1140 kW 1,800 min ⁻¹	1,530 hp 1,800 min ⁻¹
Number of cylinders (each engine)	12	
Bore	137.7 mm	5.42 in
Stroke	152.4 mm	6.0 in
Displacement	27.0 L	1,648 in ³
Aspiration	Turbocharged and charge air-cooled	
Maximum altitude without deration at 15° C (59° F) – above sea-level	1750 m	5,750 ft
Alternators	2 × 150A	
Emission	U.S. E.P.A. Flex	
Fuel tank capacity	5360 L	1,416 gal

- Hydraulically driven radiator fan with electronically controlled fan speed
- Micro processed engine management
- Heavy-duty air filters
- Two-stage fuel filter, including water separator
- Additional high-capacity water separator

Electric Motor – 6030 AC/6030 AC FS

Type	Squirrel cage induction motor	
Output	1000 kW	
Voltage	6.3 kV ± 10% (other on request)	
Rated current I _N	109A (at 6.3 kV)	
Frequency	50 Hz (60 Hz on request)	
Speed	1,500 min ⁻¹ (1,800 min ⁻¹ at 60 Hz)	
Starting current	450% of I _N (253% of I _N optional)	

- Custom-made electric motor with increased gap between rotor and stator to withstand severe mining conditions
- Power limit control by Pump Managing System

Electrical System (diesel drive)

System voltage	24V
Batteries (12V each) in series/ parallel installation	4 × 210 Ah 420 Ah – 24V
Working spotlights	8 × high brightness Xenon lights

- Battery isolation relays
- Emergency stop switches accessible from ground level and in engine module

Hydraulic System with Pump Managing System

Main pumps	4 × variable swash plate pumps	
Maximum oil flow		
Diesel version	4 × 552 L/min	4 × 146 gal/min
AC version	4 × 543 L/min	4 × 143 gal/min
Maximum pressure, attachment	310 bar	4,495 psi
Maximum pressure, travel	360 bar	5,220 psi
Swing pumps	2 × reversible swash plate double pumps	
Maximum oil flow		
Diesel version	2 × 394 L/min	2 × 104 gal/min
AC version	2 × 426 L/min	2 × 113 gal/min
Maximum pressure, swing pumps	350 bar	5,080 psi
Total volume of hydraulic oil – approximately	3500 L	925 gal
Hydraulic tank capacity – approximately	2500 L	660 gal

- Pump Managing System contains:
 - Electronic load limit control
 - Flow on demand from main pumps depending on joystick position
 - Automatic regulation of main pumps to zero flow without demand
 - Automatic RPM reduction of engine speed during working breaks
 - Reduced oil flow of main pumps at high hydraulic oil temperature or at high engine temperature
- Pressure cut-off for main pumps
- Cooling of pump transmission gear oil
- Filters:
 - Full-flow high-pressure filters (100 µm) for the main pumps, installed directly behind each pump
 - High pressure filters (100 µm) for the closed swing circuit
 - Full-flow filters (10 µm) for the complete return circuit
 - Full-flow filters (10 µm) for the cooling return circuit
 - Pressure filters (40 µm and 6 µm) for servo circuit
 - Transmission oil filters (40 µm)

Hydraulic Oil Cooling

Oil flow of cooling pumps		
Diesel version	2 × 467 L/min	2 × 123 gal/min
AC version	2 × 459 L/min	2 × 121 gal/min
Diameter of fans	2 × 1220 mm 2 × 48 in	

- Cooling system is fully independent of all main circuits, i.e. controlled cooling capacity is available whenever engine is running
- Gear-type cooling pumps supplying high-volume, low-pressure oil to fans and aluminum coolers
- Variable axial piston pumps supplying low-volume, high-pressure oil to fans
- Fan speed is thermostatically controlled
- Extremely high cooling efficiency to ensure optimum oil temperature

Swing System

Swing drives	2 compact planetary transmissions with axial piston motors
Parking brakes	Wet multiple-disc brake, spring-loaded/hydraulically released
Maximum swing speed	
Diesel version	4.6 rpm
AC version	5.0 rpm
Swing ring	Triple-race roller bearing with sealed internal gearing

- Closed-loop swing circuit with torque control
- Hydraulic braking of the swing motion by counteracting control
- All raceways of swing ring as well as grease bath for internal gearing supplied by automatic, central lubrication system

Retractable Service Station

Retractable service station installed underneath the engine module and easily accessible from ground.

Equipped with:

- Quick couplings for:
 - Diesel fuel
 - Engine coolant – left/right
 - Pump transmission gear oil – left/right
 - Engine oil – left/right
 - Hydraulic oil tank
 - Grease container
- Cat jump-start socket
- Indicator lights for fuel tanks left/right full and grease container full

6030/6030 FS Hydraulic Shovel Specifications

Operator's Cab

Operator's eye level – approximately	6.5 m	21 ft 4 in
Internal dimensions of cab		
Length	2200 mm	7 ft 3 in
Width	1600 mm	5 ft 3 in
Height	2150 mm	7 ft 1 in

- Pneumatically cushioned and multi-adjustable comfort seat with lumbar support, seat heating, safety belt, head- and armrests
- Switch in seat cushion to automatically neutralize the hydraulic controls when operator leaves the seat
- Joystick controls integrated in independently adjustable seat consoles
- Fold-away auxiliary seat with safety belt
- FOPS (rock guard; approved according to DIN ISO 3449) integrated into cab structure
- All-round safety glass, armored windshield and sliding side window
- Windshield with parallel intermittent wiper/washer
- Roller blind at windshield
- Board Control System (BCS III): Electronic monitoring, data logging and diagnostic system for vital signs and service data of engines, hydraulic and lubrication system, featuring:
 - Robust instrument panel including large (12 in) colored touch screen for intuitive handling
 - On-screen PDF documentation (e.g. operating instructions, technical handbook, spare parts catalog, electric circuit diagram)
 - On-screen trouble shooting assistance
 - Graphic charts of logged data
 - Fault memory with storage of related conditions
 - USB, Lan (TCP/IP) and CAN BUS interfaces for data export
- Machine access via retractable boarding ladder, hydraulically operated
- Emergency exit harness kit

Undercarriage

Travel speed (2 stages)		
1st stage – maximum	1.4 km/h	0.87 mph
2nd stage – maximum	2.7 km/h	1.68 mph
Maximum tractive force	1637 kN	367,880 lbf
Gradeability of travel drives – approximate	64%	
Track pads (each side)	47	
Bottom rollers (each side)	7	
Support rollers (each side)	2 plus a skid plate in between	
Travel drives (each side)	1 planetary transmission with 2 two-stage axial piston motors	
Parking brakes	Wet multiple disc brake, spring loaded/hydraulically released	

- Cast double-grouser combined pad-links with bushings connected by hardened full floating pins
- All running surfaces of sprockets, idlers, rollers and pad links, as well as teeth contact areas of sprocket and pad links, are hardened
- Fully hydraulic self-adjusting track tensioning system with membrane accumulator
- Automatic hydraulic retarder valve to prevent over-speed on downhill travel
- Acoustic travel alarm

Automatic Lubrication System

Capacity of grease container	450 L	120 gal
------------------------------	-------	---------

- Dual-circuit system with hydraulically driven heavy-duty pump and electronic time relay control to adjust the pause/lube times
- Connected to the lubrication system are the swing roller bearing with internal gearing and all pivot points of attachment, bucket and cylinders
- System failures displayed by Board Control System
- Grease filters (200 µm) between service station and container as well as directly behind grease pump

Attachments

- Booms and sticks are torsion-resistant, welded box design of high-tensile steel with solid steel castings at pivot areas
- Welding procedures allow for internal counter-welding (double prep weld) wherever possible
- Booms and sticks are stress-relieved after welding
- Catwalks with rails at boom (FS and BH)
- Pressure-free lowering of boom (FS and BH) and stick (FS) by means of a float valve
- Shovel attachment with unique TriPower kinematics ensuring the following main features:
 - Horizontal automatic constant-angle bucket guidance
 - Vertical automatic constant-angle bucket guidance
 - Automatic roll-back limiter to prevent material spillage
 - Kinematic assistance to hydraulic forces
 - Constant boom momentum throughout the whole lift arc
 - Crowd force assistance
- All buckets (FS and BH) are equipped with a wear package consisting of:
 - Special liner material covering main wear areas inside and outside of bucket
 - Lip shrouds between teeth
 - Wing shrouds on side walls
 - Heel shrouds at bottom edges
- Special wear packages for highly abrasive materials on request

Component Accessibility on Superstructure

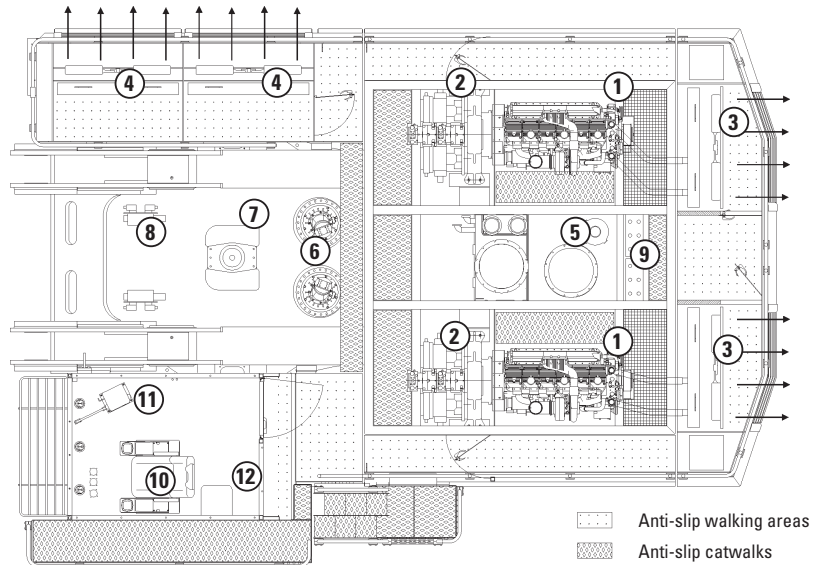

1 Diesel engines

2 Gearboxes with hydraulic pumps

3 Engine radiators with hydraulically driven fan

4 Oil coolers

5 Hydraulic tank

6 Swing drives

7 Rotary distributor

8 Travel valves

9 Batteries

10 Operator's seat

11 BCS tower

12 Auxiliary seat

6030/6030 FS Hydraulic Shovel Specifications

Dimensions

All dimensions are approximate. Dimensions and weights of AC machine differs slightly. Separate drawings, dimensions and weights can be provided upon request.

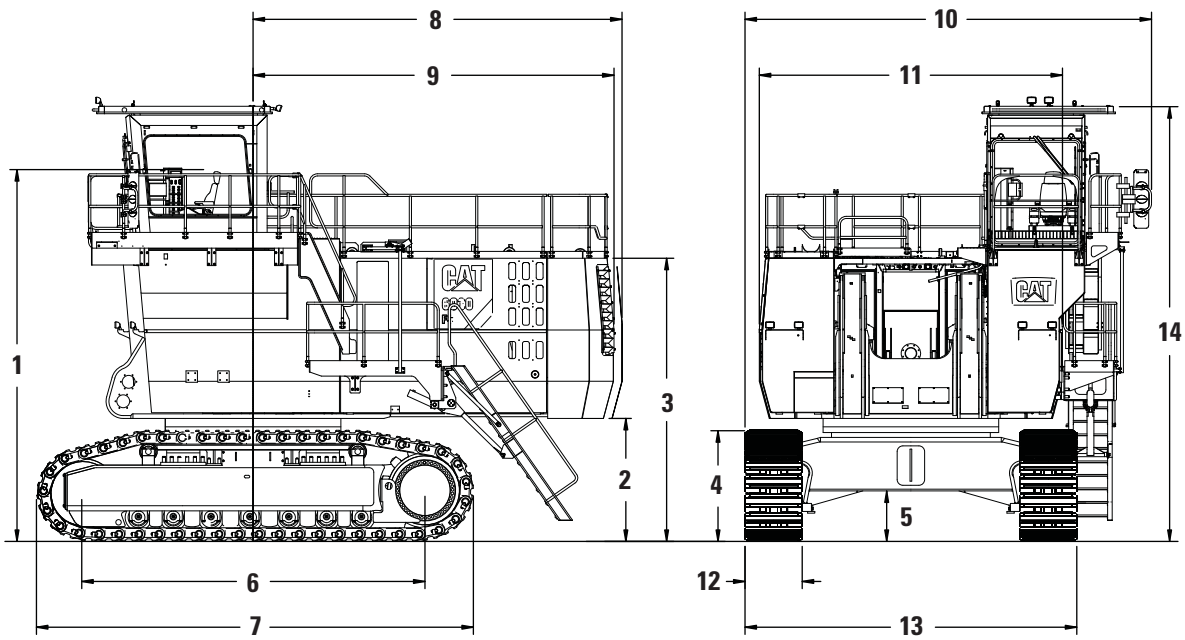

1	6500 mm	21 ft 4 in	8	6450 mm	21 ft 2 in
2	2150 mm	7 ft 1 in	9	6310 mm	20 ft 8 in
3	4950 mm	16 ft 3 in	10	7110 mm	25 ft 4 in
4	1940 mm	6 ft 4 in	11	5300 mm	17 ft 5 in
5	880 mm	2 ft 11 in	12	1000 mm	3 ft 3 in
6	5980 mm	19 ft 8 in	13	5800 mm	19 ft 0 in
7	7630 mm	25 ft 0 in	14	7600 mm	24 ft 11 in

Working Range – TriPower Face Shovel Attachment (FS)

All dimensions are approximate.

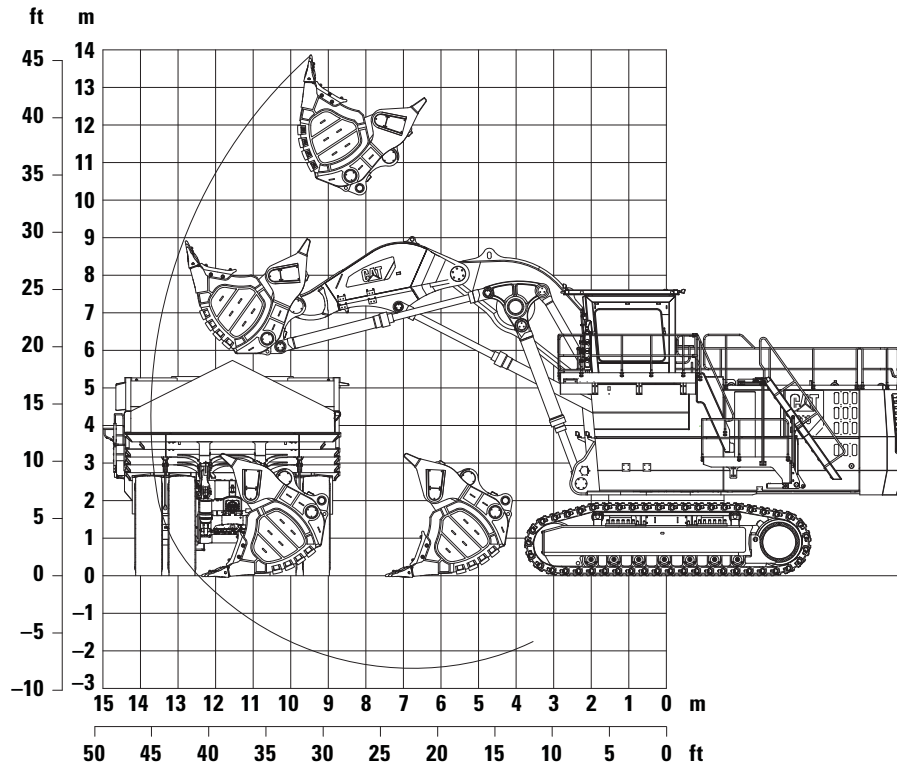

Boom	6.2 m	20 ft 4 in
Stick	4.4 m	14 ft 5 in
Digging Forces		
Maximum crowd force	1320 kN	296,640 lbf
Maximum crowd force at ground level	1210 kN	271,920 lbf
Maximum breakout force	960 kN	215,740 lbf

Boom	6.2 m	20 ft 4 in
Stick	4.4 m	14 ft 5 in
Working Range		
Maximum digging height	13.9 m	45 ft 7 in
Maximum digging reach	13.7 m	44 ft 11 in
Maximum digging depth	2.5 m	8 ft 2 in
Maximum dumping height	10.7 m	35 ft 1 in
Crowd distance on level	4.9 m	16 ft 1 in

Face Shovels

Type	Iron Ore Shovel	Iron Ore Shovel	Heavy Rock Shovel	Heavy Rock Shovel	Standard Rock Shovel
Capacity heaped 1:1	11.6 m ³ (15.2 yd ³)	13.9 m ³ (18.2 yd ³)	15.4 m ³ (20.1 yd ³)	17.0 m ³ (22.2 yd ³)	19.0 m ³ (24.9 yd ³)
Capacity heaped 2:1	10.0 m³ (13.1 yd³)	12.0 m³ (15.7 yd³)	13.5 m³ (17.7 yd³)	15.0 m³ (19.6 yd³)	16.5 m³ (21.6 yd³)
Total width	3620 mm (11 ft 11 in)	3900 mm (12 ft 10 in)	3900 mm (12 ft 10 in)	3900 mm (12 ft 10 in)	3900 mm (12 ft 10 in)
Inner width	3220 mm (10 ft 7 in)	3500 mm (11 ft 6 in)	3500 mm (11 ft 6 in)	3500 mm (11 ft 6 in)	3500 mm (11 ft 6 in)
Opening width	1680 mm (5 ft 6 in)	1790 mm (5 ft 10 in)	1790 mm (5 ft 10 in)	1790 mm (5 ft 10 in)	1790 mm (5 ft 10 in)
Number of teeth	5	6	6	6	6
Weight including wear kit	23 400 kg (51,590 lb)	26 700 kg (58,860 lb)	27 300 kg (60,190 lb)	27 500 kg (60,630 lb)	27 900 kg (61,510 lb)
Maximum material density (loose)	3.2 t/m ³ (5,390 lb/yd ³)	2.6 t/m ³ (4,210 lb/yd ³)	2.2 t/m ³ (3,710 lb/yd ³)	2.0 t/m ³ (3,370 lb/yd ³)	1.8 t/m ³ (3,030 lb/yd ³)

6030/6030 FS Hydraulic Shovel Specifications

Working Range – Backhoe Attachment (BH)

All dimensions are approximate.

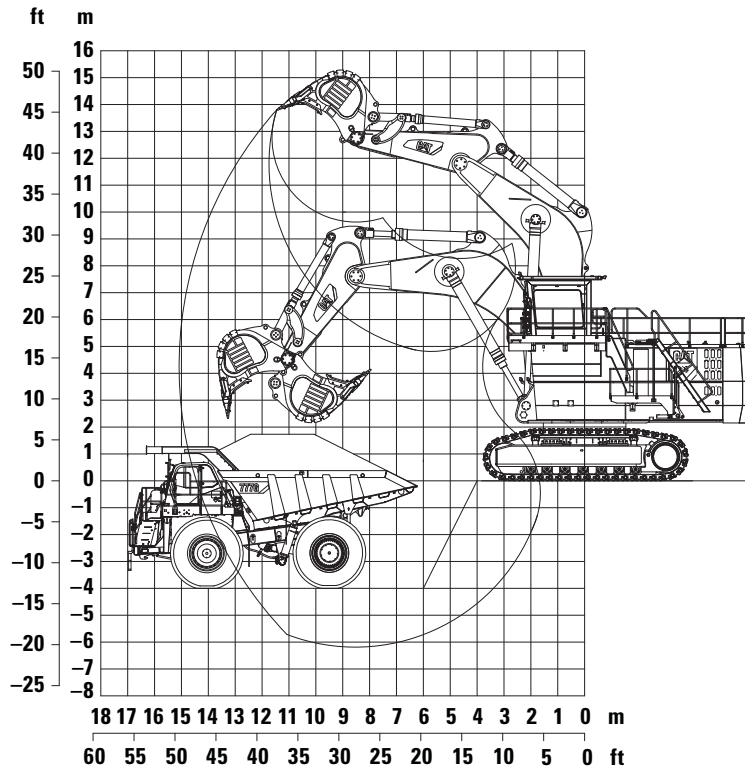

Boom	8.5 m	27 ft 11 in	Boom	8.5 m	27 ft 11 in
Stick	4.0 m	13 ft 9 in	Stick	4.0 m	13 ft 9 in
Digging Forces			Working Range		
Maximum crowd force	880 kN	197,760 lbf	Maximum digging depth	6.2 m	20 ft 4 in
Maximum breakout force	870 kN	195,520 lbf	Maximum digging reach	15.1 m	49 ft 6 in
			Maximum digging height	13.8 m	45 ft 3 in

Backhoes

Type	Iron Ore Bucket	Heavy Rock Bucket	Standard Rock Bucket
Capacity heaped 1:1	12.0 m ³ (15.7 yd ³)	15.0 m ³ (19.6 yd ³)	17.0 m ³ (22.2 yd ³)
Capacity heaped 2:1	10.9 m ³ (14.3 yd ³)	13.4 m ³ (17.5 yd ³)	15.1 m ³ (19.8 yd ³)
Capacity struck	9.6 m ³ (12.6 yd ³)	11.8 m ³ (15.4 yd ³)	13.2 m ³ (17.3 yd ³)
Total width	3450 mm (12 ft 2 in)	3880 mm (12 ft 9 in)	4360 mm (14 ft 4 in)
Inner width	3000 mm (9 ft 10 in)	3430 mm (11 ft 3 in)	3930 mm (12 ft 11 in)
Number of teeth	5	5	6
Weight including universal wear kit	15 900 kg (35,050 lb)	16 900 kg (37,260 lb)	18 800 kg (41,450 lb)
Maximum material density (loose)	2.6 t/m ³ (4,380 lb/yd ³)	2.0 t/m ³ (3,370 lb/yd ³)	1.8 t/m ³ (3,030 lb/yd ³)

General Packing List

Crawler side frame with track pads (2 units, each)

Gross weight	38 000 kg (83,770 lb)
1 Length	7700 mm (25 ft 3 in)
Width	1850 mm (6 ft 1 in)
2 Height	1950 mm (6 ft 5 in)

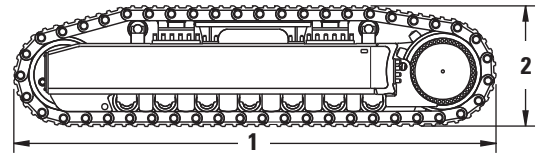

Undercarriage center frame with swing roller bearing

Gross weight	25 000 kg (55,120 lb)
1 Length	5550 mm (18 ft 3 in)
Width	3400 mm (11 ft 2 in)
2 Height	1850 mm (6 ft 1 in)

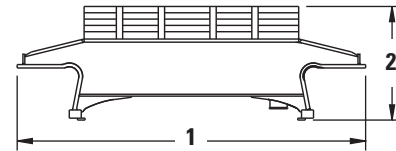

Superstructure center frame

Gross weight	34 750 kg (76,610 lb)
1 Length	8520 mm (27 ft 11 in)
Width	3120 mm (10 ft 3 in)
2 Height	2660 mm (8 ft 9 in)

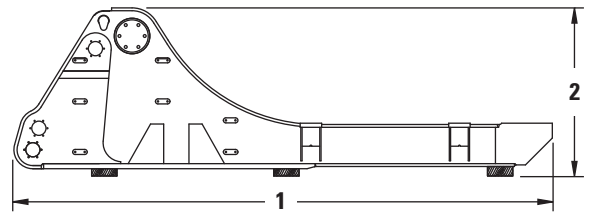

Engine module with diesel engines

Gross weight C27	25 800 kg (56,880 lb)
1 Length	3700 mm (12 ft 2 in)
Width	5300 mm (17 ft 5 in)
2 Height	3100 mm (10 ft 2 in)

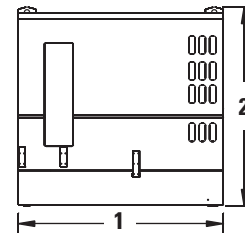

Oil cooler module

Gross weight	4900 kg (10,800 lb)
1 Length	3900 mm (12 ft 10 in)
Width	1550 mm (5 ft 1 in)
2 Height	2900 mm (9 ft 6 in)

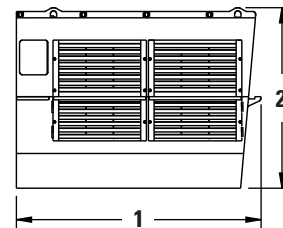

Above values are approximate. Details may vary depending on scope of supply and destination. Exact data subject to selected machine configuration and final packing list.

6030/6030 FS Hydraulic Shovel Specifications

General Packing List

Cab pedestal module

Gross weight	4830 kg (10,650 lb)
1 Length	3640 mm (11 ft 11 in)
Width	2000 mm (6 ft 7 in)
2 Height	3150 mm (10 ft 4 in)

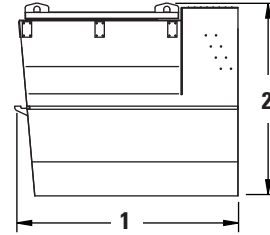

Crate with cabin and FOPS

Gross weight	3960 kg (8,730 lb)
1 Length	3500 mm (11 ft 6 in)
Width	2610 mm (8 ft 7 in)
2 Height	2870 mm (9 ft 5 in)

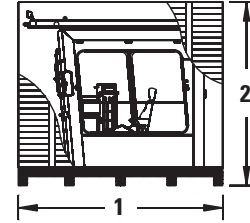

Counterweight including radiators

Gross weight	33 500 kg (73,850 lb)
1 Length	1200 mm (3 ft 11 in)
Width	5300 mm (17 ft 5 in)
2 Height	3000 mm (9 ft 10 in)

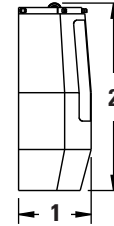

Crates

Content	1 Length	Width	2 Height	Gross Weight
2 Swing gears	1800 mm (4 ft 2 in)	1100 mm (5 ft 11 in)	2000 mm (6 ft 7 in)	2780 kg (6,130 lb)
Grease container with pump	1380 mm (4 ft 6 in)	1070 mm (3 ft 6 in)	2060 mm (6 ft 9 in)	840 kg (1,850 lb)
Barrels (hydraulic oil; grease; antifreeze)	2500 mm (8 ft 2 in)	1300 mm (4 ft 3 in)	1270 mm (4 ft 8 in)	1640 kg (3,620 lb)
Swing ring cover	2140 mm (7 ft 0 in)	2030 mm (6 ft 8 in)	1280 mm (4 ft 2 in)	600 kg (820 lb)
Retractable ladder	4400 mm (14 ft 5 in)	1100 mm (3 ft 7 in)	2000 mm (6 ft 7 in)	620 kg (1,370 lb)
Bolts	3400 mm (11 ft 2 in)	1250 mm (4 ft 1 in)	1370 mm (4 ft 6 in)	1920 kg (4,230 lb)

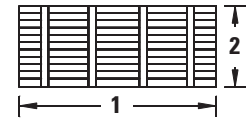

Above values are approximate. Details may vary depending on scope of supply and destination. Exact data subject to selected machine configuration and final packing list.

TriPower Shovel Attachment

Boom with main valve block, TriPower linkages and rods

Gross weight	26 400 kg (58,200 lb)
1 Length	6700 mm (22 ft)
Width	2600 mm (8 ft 6 in)
2 Height	2850 mm (9 ft 4 in)

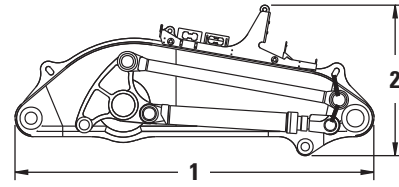

Stick

Gross weight	8840 kg (19,490 lb)
1 Length	4950 mm (16 ft 3 in)
Width	1840 mm (6 ft)
2 Height	1900 mm (6 ft 3 in)

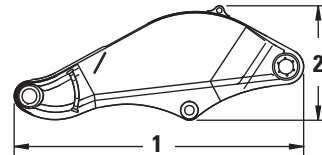

Face shovel including pin for stick

Capacity (2:1)	15.0 m ³ (19.6 yd ³)	16.5 m ³ (21.6 yd ³)
Gross weight	28 200 kg (62,170 lb)	28 600 kg (63,050 lb)
1 Length	3650 mm (12 ft)	3900 mm (12 ft 10 in)
Width	3900 mm (12 ft 10 in)	3900 mm (12 ft 10 in)
2 Height	3600 mm (11 ft 10 in)	3600 mm (11 ft 10 in)

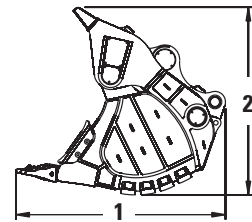

Bundle with two stick cylinders

Gross weight	3800 kg (8,380 lb)
1 Length	3950 mm (13 ft)
Width	1100 mm (3 ft 7 in)
2 Height	600 mm (2 ft)

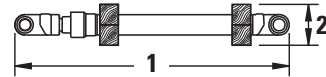

Bundle with two bucket cylinders

Gross weight	3800 kg (8,380 lb)
1 Length	3950 mm (13 ft)
Width	1100 mm (3 ft 7 in)
2 Height	600 mm (2 ft)

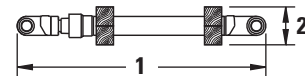

Crates with catwalks, railings and other parts

Gross weight	1400 kg (3,090 lb)	4760 kg (10,490 lb)
1 Length	3250 mm (10 ft 8 in)	5000 mm (16 ft 5 in)
Width	1850 mm (6 ft 1 in)	1900 mm (6 ft 3 in)
2 Height	920 mm (3 ft)	1740 mm (5 ft 9 in)

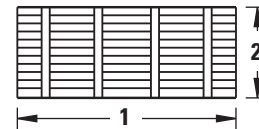

Above values are approximate. Details may vary depending on scope of supply and destination. Exact data subject to selected machine configuration and final packing list.

6030/6030 FS Hydraulic Shovel Specifications

Backhoe Attachment

Monoboom with main valve block

Gross weight	32 700 kg (72,090 lb)
1 Length	9400 mm (30 ft 10 in)
Width	2700 mm (8 ft 10 in)
2 Height	3800 mm (12 ft 6 in)

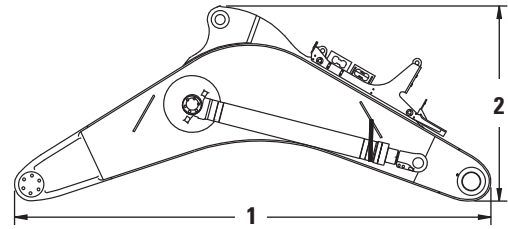

Stick with linkage and bucket cylinders

Gross weight	16 200 kg (35,710 lb)
1 Length	6000 mm (19 ft 8 in)
Width	2100 mm (6 ft 11 in)
2 Height	2300 mm (7 ft 7 in)

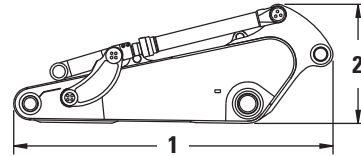

Backhoe bucket including pin for stick

Capacity (1:1)	15.0 m ³ (19.6 yd ³)	17.0 m ³ (22.2 yd ³)
Gross weight	17 600 kg (38,800 lb)	19 500 kg (42,990 lb)
1 Length	3800 mm (12 ft 6 in)	3850 mm (12 ft 8 in)
Width	3700 mm (12 ft 2 in)	4150 mm (13 ft 7 in)
2 Height	2900 mm (9 ft 6 in)	2900 mm (9 ft 6 in)

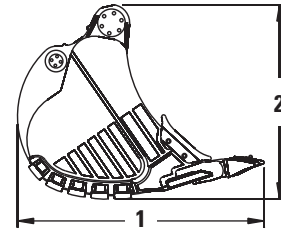

Bundle with two stick cylinders

Gross weight	6350 kg (14,000 lb)
1 Length	4250 mm (13 ft 11 in)
Width	1200 mm (3 ft 11 in)
2 Height	610 mm (2 ft)

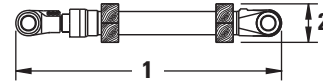

Crates with catwalks, railings and other parts

Gross weight	3200 kg (7,050 lb)	1010 kg (2,230 lb)
1 Length	4950 mm (16 ft 3 in)	3250 mm (10 ft 8 in)
Width	1900 mm (6 ft 3 in)	1850 mm (6 ft 1 in)
2 Height	1900 mm (6 ft 3 in)	920 mm (3 ft)

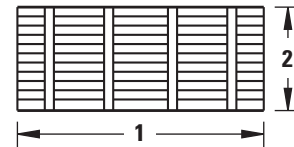

Above values are approximate. Details may vary depending on scope of supply and destination. Exact data subject to selected machine configuration and final packing list.

Optional Equipment

Optional equipment may vary. Consult your Cat dealer for details.

GENERAL

- Export crating
- Finishing as per end user's corporate colors

SUPERSTRUCTURE

- Mechanical service crane on superstructure
- Hydraulic service crane on superstructure with auxiliary engine
- Folding access stairway, stairway angle approximately 45°

- Round container with a standard 200 L (53 gal) grease barrel (instead of 450 L (119 gal) grease container)
- Lubricated pinion for greasing of internal gearing of swing ring
- Various cold-weather packages

CAB

- Various heating and air-conditioning systems
- Roller blinds at all windows
- Outside-mounted sun shields

UNDERCARRIAGE

- Track pad width 800 mm (2 ft 7 in) or 1200 mm (3 ft 11 in)
- Automatic lubrication of rollers by central lube system
- Cover plate under carbody (belly plate)

ATTACHMENT

- Guards for shovel cylinders of FS attachment
- Xenon lighting on boom
- Special wear packages

Additional optional equipment available on request.

For more complete information on Cat products, dealer services, and industry solutions, visit us on the web at www.cat.com

AEHQ6967-01 (07-2013)
Replaces AEHQ6967

© 2013 Caterpillar Inc.
All rights reserved

Materials and specifications are subject to change without notice. Featured machines in photos may include additional equipment. See your Cat dealer for available options.

CAT, CATERPILLAR, SAFETY.CAT.COM, their respective logos, "Caterpillar Yellow" and the "Power Edge" trade dress, as well as corporate and product identity used herein, are trademarks of Caterpillar and may not be used without permission.

