

# 6030/6030 FS

Hydraulic Shovel



## Engine\*

Engine Model	2 × Cat® C27 ACERT™	
Gross Power – SAE J1995	1140 kW	1,530 hp
Net Power – SAE J1349	1140 kW	1,530 hp

\*Electric drive option available (1000 kW) on 6030 AC/6030 AC FS

## Bucket

Bucket Capacity – Front Shovel (heaped 2:1)	16.5 m <sup>3</sup>	21.6 yd <sup>3</sup>
Bucket Capacity – Backhoe (heaped 1:1)	17.0 m <sup>3</sup>	22.2 yd <sup>3</sup>

## Operating Specifications

Bucket Payload	30 tonnes	34 tons
Operating Weight – Front Shovel	294 tonnes	324 tons
Operating Weight – Backhoe	296 tonnes	326 tons

## 6030/6030 FS Features

With over 300 deliveries world-wide, the Cat 6030/6030 FS is our most popular and best-selling hydraulic mining shovel model. Along with the same advanced technology available on its larger Cat counterparts, the 6030/6030 FS provides the most powerful engine output in its class for added productivity and facilitates the mobility and flexibility you need from a 300 tonne machine. When optimally paired with our 777 or 785 Series mining trucks, you'll experience the operational efficiency and productivity you're looking for, supported by our unmatched Cat dealer network.

### Contents

Drive Systems.....	4
Twin-engine Concept.....	5
TriPower System (Front Shovel Machines)....	6
Hydraulic System.....	8
Independent Oil Cooling System.....	9
Pump Managing System.....	10
Closed-loop Swing Circuit.....	11
Operator's Cab.....	12
Electronic Control System.....	13
Cat MineStar™ System and Technology Solutions.....	14
Loading/Hauling Efficiency.....	16
Front Attachment Options and Structures....	17
Swing System.....	18
Undercarriage.....	19
Safety.....	20
Customer Support.....	21
Serviceability.....	22
Sustainability.....	23
Specifications.....	24
Optional Equipment.....	30
Notes.....	31





# Every Day Matters, Every Load Counts

**We understand the challenges you face, the importance of reliability, and the relationship between uptime and productivity. That's why we continually strive to produce the safest, most reliable and productive hydraulic shovels possible. Offering the widest payload range of any manufacturer in the industry, the ability to optimally pair with our popular line of mining trucks, and the support of our world-class Cat dealer network, we are uniquely positioned to partner with you to help achieve your productivity targets. We understand what matters to you. Our hydraulic shovels are built with you in mind. Because in mining, every day matters and every load counts.**

# Drive Systems

Balanced Combination of Power and Efficiency



## Meeting Your Site Specific Needs with a Choice of Robust Drive System Options

Giving you the option to choose the drive system best suited for your operation, the Cat 6030/6030 FS can be equipped with either two Cat C27 ACERT diesel engines for greater mobility, or an electric drive for better efficiency.

### • Reliable Cat C27 ACERT Engine

Delivering durable, reliable power that will keep your primary loading tool producing, the C27 ACERT is one of the most widely used engines in the mining industry, proving its ability to stand-up to the harshest conditions while providing the mobility and flexibility you desire.

Boosting your productivity, the C27 ACERT equipped Cat 6030/6030 FS offers the most powerful engine output in its size class.

### • Efficient Electric Drive System on 6030 AC/6030 AC FS

Providing a lower cost-per-ton alternative to diesel powered hydraulic shovels, our electric drive option maintains the ruggedness you need and offers superior availability since no refueling and less service is required.

The 6030 AC/6030 AC FS is the ideal solution for operations that do not require a great deal of mobility and value a low cost-per-ton model.



## Twin-engine Concept

Stay Up and Running More Consistently

### Keep Producing and Ensure the Safety of Your Operators, Even During Single Engine Loss

You will realize enhanced safety, greater uptime, more productivity, and better serviceability as a result of our twin-engine concept.

- **Enhanced Safety**

The ability to move your shovel to a safe area for repair, away from high walls, blast zones, or other safety hazards, is still possible with the use of a single engine.

- **Greater Uptime and More Productivity**

Up to 65% of full production can still be achieved with the use of a single engine. This is due to the shovel's continued ability to exert maximum digging forces, to lower the front attachment without requiring engine power (i.e., pressure-free), and to recuperate energy via its closed-loop swing circuit.

- **Better Serviceability**

Troubleshooting is greatly simplified and expedited with the ability to compare one engine versus the other.

# TriPower System (Front Shovel Machines)

Superior Digging Capability and Bucket Fill Factors



## Dig More Effectively with Our Unique TriPower Front Shovel Design

You will experience enhanced, easier and faster front shovel operation with TriPower, a system proven on over a thousand Cat hydraulic shovels worldwide. Generating superior mechanical leverage and control, our FS configured hydraulic shovels utilize a unique boom design that employs rotatable triangular rockers. This design facilitates quicker cycle times, increased effective lifting force, constant boom momentum, automatic constant bucket angle, and automatic roll-back limiter.



- **Quicker Cycle Times**

- Faster lifting speeds are achieved, because the design enables the use of smaller-diameter boom cylinders.

- **Increased Effective Lifting Force**

- Design transfers digging forces into the superstructure, creating supporting boom momentum in addition to momentum that is generated hydraulically.

- **Constant Boom Momentum**

- Allows smaller boom cylinders for higher lifting speed.
- Keeps lifting speed constant.
- Enables the shovel to lift a single load along the entire digging distance.
- No retracting of stick cylinders is required, ensuring that all hydraulic pumps are supplying the boom-up function.

- **Automatic Constant Bucket Angle**

- Material spillage is avoided during boom lifting, because the filled bucket automatically maintains a constant bucket angle.
- On conventional kinematics the operator has to control manually the bucket position during lifting which cut in half the available oil flow for the boom cylinders.

- **Automatic Roll-back Limiter**

- Preventing material spillage back on to the operator's cab and machine superstructure, our system ensures that the bucket is always in a safe position, without operator control/manipulation, when it is at maximum height.
- The boom cylinder continues to receive maximum oil flow, because the operator does not need to activate the bucket cylinder.





# Hydraulic System

Easy Serviceability and Greater Productivity

## **Straightforward, Safe System Maintenance**

Ensuring neat organization for safe operation, easy inspection, and fast service, and reducing the number of hoses needed, the main valve block is located on top of the boom.

## **Faster Cycle Times**

Faster cycle times are realized, because float valves are used to lower the boom instead of engaging pumps. This facilitates faster boom movements and allows other operating functions to occur simultaneously, such as bucket curl and stick in/out.

## **Greater Control**

Your operators will experience greater control with our five circuit hydraulics, allowing for two cylinder motions, two travel motions, and swing to be controlled simultaneously.



## Protect and Extend the Life of Your Hydraulic Components

Providing a more efficient means of cooling, particularly in demanding applications, our unique independent oil cooling system will extend the life of your hydraulic shovel's components.

## More Efficient Oil Cooling

Our system is independent of return oil, achieving efficiency through the utilization of dedicated pumps that provide cooling capacity as needed, whether the engine is idling or under load. That means optimum oil temperature is being maintained, even while your operator waits for the next truck to load. Competitive hydraulic shovels only provide cooling when the machine is working and the engine is under load.

Additional efficiency is achieved via our thermostatically controlled radiator fan speed. The fans do not run until oil temperature exceeds a temperature of 50° C (122° F), saving energy.

## Optimal Oil Temperature Maintained

The high-efficient oil cooling system ensures that the oil temperature is only 25° to 30° C (45° to 54° F) higher than the ambient temperature. Thus, the hydraulic oil's working temperature remains within the optimal operating viscosity range of 50° to 70° C (122° to 158° F).



## **Experience Improved Machine Control and Component Life, while Reducing Fuel Consumption and Noise Emission, with Our Intelligent Pump Managing System**

Delivering optimal performance, our pump managing system continuously evaluates actual engine and hydraulic operating values against set values, and adjusts pump output accordingly. This results in efficient use of the engine for greater productivity.

Pump managing system advantages include:

- Best possible utilization of engine output and engine overload avoidance via electronic load limit regulation
- Less energy consumption and less thermal load on hydraulic oil with zero oil flow regulation for main pumps
- Less fuel consumption and lower noise emission via automatic RPM reduction
- Reduced component wear and lower noise emission with automatic oil flow reduction for closing/opening of bucket clam
- Protection of components with automatic oil flow reduction if hydraulic and/or engine coolant temperature exceed set maximum
- Improved operator control response via on-demand pump flow

## **Pump Managing System**

Enhanced Efficiency, Component Life,  
and Control Response



# Closed-loop Swing Circuit

More Efficient Energy Use and  
Faster Boom Lift Motion During Swing



## Load More Material, at Lower Cost, with the Energy Recovery Capability of Our Closed-loop Swing System

Delivering faster cycle times and improved energy efficiency, while also generating less heat, our closed-loop swing circuit provides distinct advantages over competitive machines utilizing open-circuit swing systems.

### Greater Efficiency via Energy Recovery

Kinetic energy captured during the swing motion is fed back into the system during deceleration, providing more power to drive the main and auxiliary pumps. Energy is saved during deceleration, because braking occurs via counteracting controls, as opposed to throttles used in open circuit swing systems.

### Energy Savings During Acceleration

Energy is saved during acceleration via torque control, providing a pressure balance valve that controls the swing pump against pressure in the closed-loop swing circuit, ensuring that only the minimum necessary oil flow is utilized at any given time.

### Faster Cycle Times

Faster boom lift motion during swing is achieved with our closed-loop swing system, increasing overall productivity.

# Operator's Cab

Ensuring the Safety and Comfort of Your Operators



## Get Peak Operator Performance with Our Safe and Comfortable Operator's Cab

We understand that the most important factor in your hydraulic shovel's effectiveness is the performance of its operator. To help make their workday as productive as possible, we've incorporated safety and comfort features into the 6030/6030 FS operator's cab.

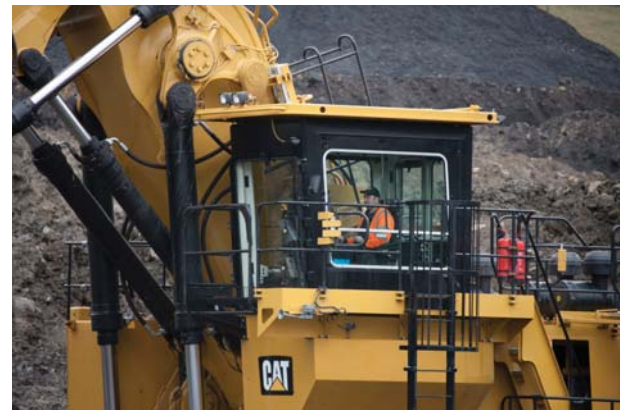

## Protection for Your Operator; Every Day, Every Shift

- Safety glass is used for all cab windows, and armored glass for the windshield.
- Operator's seat is equipped with integrated safety switch that automatically neutralizes the hydraulic controls when the operator leaves the seat.
- The height of the cab module ensures an eye level of approximately 6.5 m (21 ft 4 in), providing excellent visibility of the digging and loading areas.
- Cab meets Falling Object Protection System (FOPS) and DIN ISO 3449 standards.

## Supporting Peak Operator Performance with Comfort Features

- Pneumatically cushioned, multi-adjustable operator's seat.
- Large, transfective color touch-screen display (BCS III) provides vital machine monitoring and diagnostic data for convenient troubleshooting and service assistance.



# Electronic Control System

## Operate with Confidence

### Enhanced Control Response and Optimized Hydraulic Engine Load Management

Help your team meet productivity and performance standards with our intuitive, informative on-board electronics.

### Electro-Hydraulic Servo Control

- **Enhanced Control Response**

The system relays actuating signals from the joysticks, delivering fast and precise machine reactions facilitate a reduction in operator fatigue.

- **Increased Uptime**

Uptime is increased as a result of simplified troubleshooting and advanced diagnostic capabilities.

- **Greater Operator Comfort**

Easier setting of servo control characteristics allow operators to adjust to their preference.

- **Clean and Quiet Cab Environment**

No hydraulic lines are present in the cab or the cab module, ensuring a clean arrangement with less noise emission.

### Control and Monitoring Platform (CAMP)

- **Reduced Control System Inventory**

Streamlined system requires only one type of controller for each function (i.e., left side drive train, right side drive train, servo, and auxiliary) reducing the number of required controllers in the system and associated replacement stock.

- **Less Fuel Consumption**

Engine works in optimal range of performance during the entire digging cycle, reducing fuel burn.

- **Increased Component Life**

Reduced hydraulic pulsation lessens stress imposed on the engine and hydraulic components.

- **Enhanced Operator Comfort**

Less vibration and more even machine movement via reduced pressure peaks.

- **On-screen Documentation**

Parts book, Technical and Operating handbook, as well as hydraulic and electric schematics are available in electronic format.



# Cat MineStar System and Technology Solutions

Evolving Your Mine for Greater Safety and Productivity

## Helping You Enhance Safety and Productivity Through Technology

Aimed at enhancing the productivity and profitability of your hydraulic shovel, we currently offer a combination of Cat MineStar System offerings and Cat hydraulic shovel technology solutions.



## Cat MineStar System

Helping you achieve your goals for enhanced mine site safety, improved efficiency, reduced operating costs, and greater profitability, the Cat MineStar System provides the most comprehensive suite of mining technology products in the industry. It consists of a number of configurable capability sets – Fleet, Terrain, Detect, Health, and Command – that allow you to scale the system to your mine site needs. Cat MineStar System helps you manage everything from material tracking to sophisticated real-time fleet management, machine health systems, autonomous equipment, and more.

The Cat 6030/6030 FS is able to utilize the following Cat MineStar System capability sets:

- **Fleet**

Fleet provides real-time machine tracking, assignment and productivity management, providing a comprehensive overview of all your asset operations from anywhere in the world.

- **Terrain**

Terrain enables high-precision management of drilling, dragline, grading and loading operations through the use of guidance technology. It increases machine productivity and provides you real-time feedback for improved efficiency.

- **Detect**

Detect helps increase operator awareness, enhancing safety at your operation. It includes a range of capabilities designed to assist the operator, including blind spot and proximity detection of fixed and mobile equipment.

- **Health**

Health delivers critical event-based machine condition and operating data for your entire fleet. It includes comprehensive equipment health and asset monitoring capabilities, with a wide range of diagnostic, analytic and reporting tools.

## Hydraulic Shovel Technology Solutions

- **Monitoring and Diagnostic System**

Enhancing diagnostic capabilities and providing detailed troubleshooting functions, our Board Control System uses sensors throughout the machine to monitor operating data, record faults, and notify the operator audibly and visually. This promotes the earliest possible detection of faults and allows for timely maintenance planning and assistance for speedy repair.



# Loading/Hauling Efficiency

Move More Material with Optimal Pass Match Pairings



## Achieve Targeted Loading/Hauling Production with Perfectly Paired Cat Hydraulic Shovels and Mining Trucks

For full truck payloads with minimum loading time, an efficient loading/hauling system begins with an optimized equipment match. Cat hydraulic shovels are matched with Cat mining trucks to maximize volume of material moved at the lowest operating cost per ton.

### 6030/6030 FS Pass Match with Cat Mining Trucks

	777G/777E/777D	785D/785C	789D
	90 tonne (100 ton)	136 tonne (150 ton)	181 tonne (200 ton)
6030/6030 FS	3-4	5	6





## Rugged Front Attachment Options Designed and Fabricated to Withstand Your Extreme Mining Conditions

To extend service life and ensure that your shovel keeps producing, our front attachment structures are designed for durability and dependability. Whether you equip your hydraulic shovel in backhoe or front shovel configuration, extended performance in the harsh mining conditions you face daily is accomplished through selection of high-strength steels and rugged castings, joined and thermally stress-relieved, to help you achieve your productivity targets.

### Front Attachment Structures Include:

- Heavy castings at all pivot points
- Better flow of forces and less welding seams, as top chords are made of one bend plate
- Entire boom and stick are stress relieved after welding
- Welding procedures allow for internal welding (double prep weld)



## Front Attachment Options and Structures Bolstering Your Investment with Robust and Durable Structures





## Swing System

Longer Component Life for Better  
Swing System Reliability

### **More Reliable Swing Component Life**

Extending component life and ultimately improving machine uptime, our swing system includes a triple-race swing roller bearing with internal gearing connected to an automatic lubrication system.

For added reliability, all lube lines are located inside the roller bearing for maximum protection.

### **Powerful Productivity**

For maximum swing power and faster cycle times, the 6030/6030 FS utilizes the same swing gears as its larger Cat counterparts.

### **Service Friendly**

Easier maintenance is afforded by the free accessibility of swing gears and rotary distributor.



# Undercarriage

## Tough and Long-lasting

### Durable, Long-life Undercarriage Design, Built to withstand the Harshest Underfoot Conditions

6030/6030 FS features a redesigned undercarriage for added durability and reliable performance. A two-stage track tensioning system, utilizing both low pressure and high pressure accumulators with new 13-tooth sprockets, reduces impact and is capable of handling the most extension track tension, extends undercarriage component life and provides a more comfortable ride for the operator. Likewise, the vertical position of the support rollers has been modified, and the amount of chain slack is reduced, to further extend tension system and chain life.

Track pads have a broadened and reinforced running surface, increasing wear volume by approximately 40%, and reinforced pin retention allows for better tolerance of impact between track pads and the blank holder.

The 6030/6030 FS undercarriage also features newly designed fixed axle rollers for improved durability and reduced owning and operating costs. The new fixed axle roller design provides:

- 1. A robust single piece rim** – The new roller body is forged utilizing high strength and wear resistant materials which results in superior performance and durability. Further, it is thru-hardened to deliver excellent wear resistance throughout its life.
- 2. Caterpillar proprietary bearing and sealing technology** – Optimized load transfer, superior bushing technology and Cat high performance seals result in a roller that is maintenance free for life. With the Caterpillar proprietary sealing system, combined with Cat precision seals, the result is a roller that can go the distance. Based on field test data, the new fixed-axle roller design is yielding considerable improvement in life compared to the previous generation.
- 3. Run-cool roller technology** – High performance lubricant and Caterpillar proprietary technology results in much lower operating temperatures and enhances the performance over the life of the roller. Field tests have demonstrated much cooler operation, even during long distance propels. This enhancement results in significant improvement in long distance travel performance, reduced need for compulsory cooling periods, and reduced risk of roller damage.
- 4. Elimination of central lubrication system to the undercarriage** – With the Caterpillar proprietary sealing technology and high performance tribology solutions, the new fixed axle rollers are able to deliver superior performance without the need for continuous lubrication, reducing owning and operating costs.
- 5. Easier assembly** – Total installation requires only two steps, allowing for quicker field assembly.
- 6. Proven Caterpillar design** – Leveraging 100 years of Caterpillar undercarriage innovation, the design concept stems from field proven designs used on virtually all Cat machines with tracked undercarriages, ensuring consistent and reliable performance.

# Safety

## Designed with Your Safety as Our Top Priority



Sharing your commitment to safety, and driven by our commitment to Zero Harm, we work tirelessly to design the safest machines possible to protect your most important asset; your employees. That is why we updated the design of the 6030/6030 FS in accordance with the principles of MDG 41 and 15, and offer this standard, not as an option or upgrade. Some examples of the safety-enhancing features of the Cat 6030/6030 FS hydraulic mining shovel include the following:

### Machine Access

- All stairways have 45° angle for safe and comfortable access and movement about the machine.
- Slide down emergency egress ladder directly adjacent to the operator's cab.
- Hydraulically operated boarding ladder with emergency lowering via nitrogen accumulator ensures that ladder remains operational even when engines shut off.
- Machine swing and propel capability is switched-off when ladder is in down position.

### Service and Maintenance

- Improved routing and clamping of hydraulic hoses.
- Hydraulic hoses and electrical wiring are separated from each other for fire prevention.
- All service areas are accessible via anti-slip walkways, and trip hazards are eliminated.
- All hot surfaces are covered to prevent burns.

### Electrical System

- Cabinet with battery isolation switch, mounted on top deck directly above the battery box, allows quick and easy shut-off of voltage on the entire shovel.
- Cabinet contains a starter isolator which allows on-board voltage, but prevents starting of engines.

### Emergency Shut-offs

- An easily accessible, standard shut-off switch located in the cab shuts down the electrical system in case of emergencies.
- Additional shut-off switches are located on the machine, in the machine house or accessible from the ground.

### Precise Bucket Control

- Minimizing the potential for material spill on to the attachment or cab, the TriPower automatic roll-back limiter prevents the bucket from being curled back too far.



# Customer Support

## Stay Up and Running with Service and Support from Our Unmatched Global Network

### **Commitment Makes the Difference**

Cat dealers offer a wide range of solutions, services and products that help you lower costs, enhance productivity and manage your operation more efficiently. From the time you select a piece of Cat equipment until the day you trade or sell it, the support you get from your Cat dealer makes the difference.

### **Dealer Capability**

Cat dealers provide the level of support you need, on a global scale. Dealer expert technicians have the knowledge, experience, training and tooling necessary to handle your repair and maintenance needs, when and where you need them.

### **Product Support**

When Cat products reach the field, they are supported by a worldwide network of parts distribution facilities, dealer service centers and technical training facilities to keep your equipment up and running. Cat customers rely on prompt, dependable parts availability through our global dealer network, ready to meet your needs 24/7.

### **Service Support**

Every piece of Cat equipment is designed and built to provide maximum productivity and operating economy throughout its working life. Cat dealers offer a wide range of service plans that will maximize uptime and return on your investment, including:

- Preventive Maintenance Programs
- Diagnostic Programs, such as Scheduled Oil Sampling and Technical Analysis
- Rebuild and Reman Option
- Customer Support Agreements

### **Application Awareness**

Operating and maintenance costs are influenced by many application and site-specific factors, such as: material density and fragmentation, payload, bench height, truck positioning, ground conditions, amount of traveling and maintenance. Your Cat dealer can provide you with an understanding of the effects application characteristics and operating techniques have on maintenance and operating costs.

### **Operation**

Your Cat dealer can arrange training programs to help operator's improve productivity, decrease downtime, reduce operating costs and enhance safety.

# Serviceability

Designed to Get You Back to Work Fast

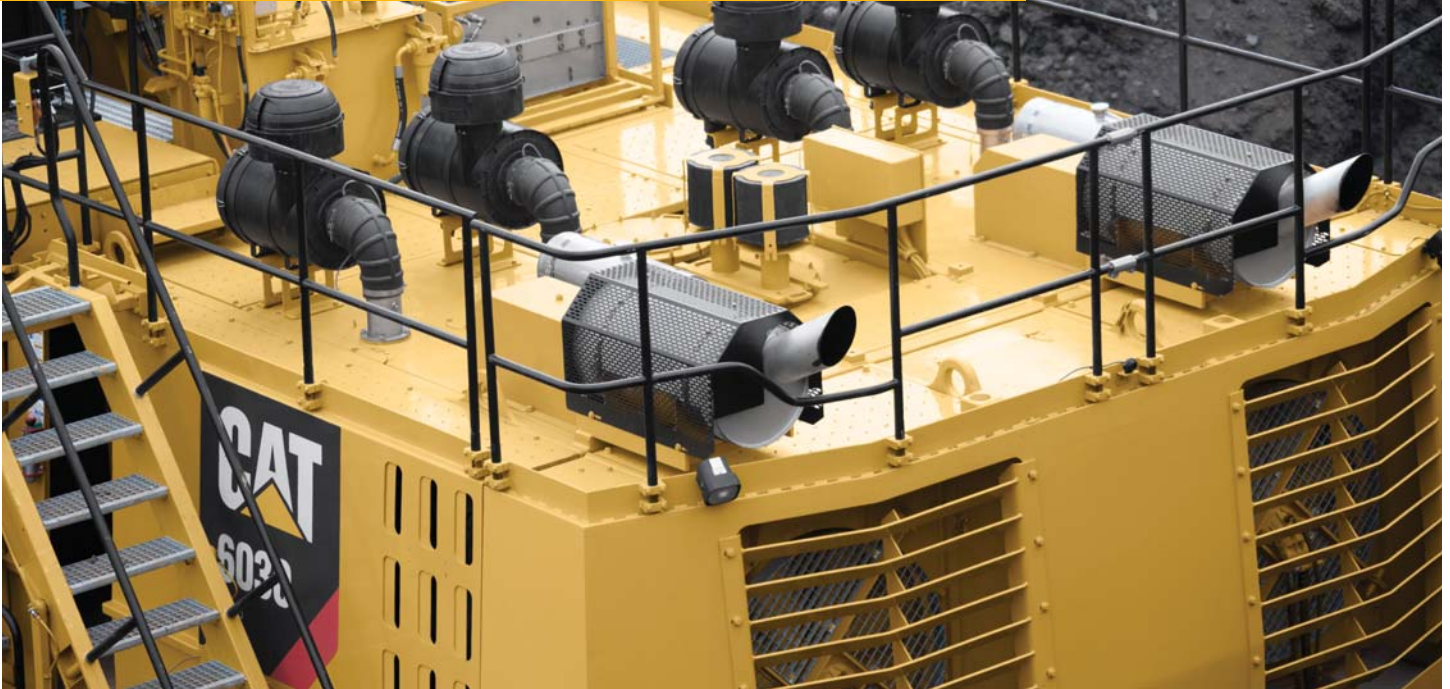

Lowering your operating costs and maximizing your hydraulic shovel's uptime and productivity is of supreme importance to us. To that end, we've made vital components more accessible and designed simpler systems to make maintenance activities quicker and easier.

## Open, Spacious Access to Components

- Facilitating easier maintenance, exceptional accessibility is provided to systems like the swing motor, swing gearbox and rotary distributor in the well organized superstructure.
- Easily accessed by walkways on both sides, the boom-mounted main valve block, a feature unique to Cat Hydraulic Shovels, provides a clean layout and reduces the number of hoses leading from the superstructure to the attachment.

## Simple Hydraulic System with Main Valve Block Positioned on Boom

- Ensuring neat organization for safe operation, easy inspection and fast service, the design of our hydraulic system significantly reduces the total number of frequently moving hoses from the superstructure to the attachment.
- Longer hose life via improved routing in accordance with MDG design standards.

## Easy Ground-level Fuel and Fluid Replenishment

- Quick fuel and fluid replenishment is made easy with a retractable service station underneath the engine module, accessible at ground-level.

## Improved Drive Train Troubleshooting

- Twin-engine design facilitates troubleshooting of drive trains, as one engine can be compared to the other.



# Sustainability

## Higher Standards for a Better Tomorrow

Meeting the needs of today without compromising the needs of tomorrow is the goal for all Cat machinery. The commitment to helping you operate safely and sustainably is affirmed in the production of the 6030/6030 FS hydraulic shovel.

### **Cat Hydraulic Shovel Sustainability**

- **Electric Power Option**

Reduce your carbon footprint with our lower emission electric drive option.

- **Energy Recovery**

Emit less heat and improve energy efficiency via the energy recovery capability of the closed-loop swing circuit.

- **Rebuilds**

Decrease your energy use and material consumption with a machine that's designed to be rebuilt.

# 6030/6030 FS Hydraulic Shovel Specifications

## General Data

Operating weight		
Face Shovel	294 tonnes	324 tons
Backhoe	296 tonnes	326 tons
Engine output SAE J1995		
2 × Cat C27 ACERT	1140 kW	1,530 hp
Standard bucket capacity		
Face Shovel (heaped 2:1)	16.5 m <sup>3</sup>	21.6 yd <sup>3</sup>
Backhoe (heaped 1:1)	17.0 m <sup>3</sup>	22.2 yd <sup>3</sup>

## Features

- TriPower shovel attachment
- Independent oil cooling system
- Spacious walk-through machine house
- 5-circuit hydraulic system
- On-board electronics system: Control and Monitoring Platform (CAMP)
- Board Control System (BCS III)
- Torque control in closed-loop swing circuit
- Automatic central lubrication system
- LED working lights

## Operating Weight

6030 FS		
Standard track pads	1000 mm	3 ft 3 in
Operating weight	294 300 kg	648,810 lb
Ground pressure	21.9 N/cm <sup>2</sup>	31.7 psi

6030		
Standard track pads	1000 mm	3 ft 3 in
Operating weight	296 500 kg	653,660 lb
Ground pressure	22.1 N/cm <sup>2</sup>	32.0 psi

- Other track pads available on request

## Diesel Engines

Make and model	2 × Cat C27 ACERT	
Total rated net power – ISO 3046/1	1140 kW	1,530 hp
	1,800 min <sup>-1</sup>	1,800 min <sup>-1</sup>
Total rated net power – SAE J1349	1140 kW	1,530 hp
	1,800 min <sup>-1</sup>	1,800 min <sup>-1</sup>
Total rated gross power – SAE J1995	1140 kW	1,530 hp
	1,800 min <sup>-1</sup>	1,800 min <sup>-1</sup>
Number of cylinders (each engine)	12	
Bore	137.7 mm	5.42 in
Stroke	152.4 mm	6.0 in
Displacement	27.0 L	1,648 in <sup>3</sup>
Aspiration	Turbocharged and charge air-cooled	
Maximum altitude without deration at 25° C (77° F) – above sea-level	500 m	1,640 ft
Alternators	2 × 150A	
Fuel tank capacity	5070 L	1,339 gal

- Meets U.S. EPA Tier 2 equivalent emission standards
- Hydraulically driven radiator fan with electronically controlled fan speed
- Micro processed engine management
- Heavy-duty air filters
- Two-stage fuel filter, including water separator
- Additional high-capacity water separator

## Electric Motor – 6030 AC/6030 AC FS

Type	Squirrel cage induction motor
Output	1000 kW
Voltage	6.3 kV ± 10% (other on request)
Rated current I <sub>N</sub>	109A (at 6.3 kV)
Frequency	50 Hz (60 Hz on request)
Revolutions	1,500 min <sup>-1</sup> (1,800 min <sup>-1</sup> at 60 Hz)
Starting current	450% of I <sub>N</sub> (253% of I <sub>N</sub> optional)



# 6030/6030 FS Hydraulic Shovel Specifications

## Electrical System (diesel drive)

System voltage	24V
Batteries in series/parallel installation	4 × 210 Ah – 12V each 420 Ah – 24V in total

- Battery isolation relays
- Emergency stop switches accessible from ground level and in engine module
- 12 LED high-brightness working flood lights
  - 8 for working area
  - 2 for rear end
- 2 LED high-brightness access flood lights
- 14 LED service lights

## Hydraulic System with Pump Managing System

Main pumps	4 × variable swash plate pumps	
Maximum oil flow		
Diesel version	4 × 552 L/min	4 × 146 gal/min
AC version	4 × 543 L/min	4 × 143 gal/min
Maximum pressure, attachment	310 bar	4,495 psi
Maximum pressure, travel	360 bar	5,220 psi
Swing pumps	2 × reversible swash plate double pumps	
Maximum oil flow		
Diesel version	2 × 394 L/min	2 × 104 gal/min
AC version	2 × 426 L/min	2 × 113 gal/min
Maximum pressure, swing pumps	350 bar	5,080 psi
Total volume of hydraulic oil – approximately	3500 L	925 gal
Hydraulic tank capacity – approximately	2500 L	660 gal

- Pump Managing System contains:
  - Electronic load limit control
  - Flow on demand from main pumps depending on joystick position
  - Automatic regulation of main pumps to zero flow without demand
  - Automatic RPM reduction of engine speed during working breaks
  - Reduced oil flow of main pumps at high hydraulic oil temperature or at high engine temperature
- Pressure cut-off for main pumps
- Cooling of pump transmission gear oil
- Filters:
  - Full-flow high-pressure filters (100 µm) for the main pumps, installed directly behind each pump
  - High pressure filters (100 µm) for the closed swing circuit
  - Full-flow filters (10 µm) for the complete return circuit
  - Full-flow filters (10 µm) for the cooling return circuit
  - Pressure filters (40 µm and 6 µm) for servo circuit
  - Transmission oil filters (40 µm)

## Hydraulic Oil Cooling

Oil flow of cooling pumps		
Diesel version	2 × 467 L/min	2 × 123 gal/min
AC version	2 × 459 L/min	2 × 121 gal/min
Diameter of fans	2 × 1220 mm 2 × 48 in	

- Cooling system is fully independent of all main circuits, i.e. controlled cooling capacity is available whenever engine is running
- Gear-type cooling pumps supplying high-volume, low-pressure oil to fans and aluminum coolers
- Variable axial piston pumps supplying low-volume, high-pressure oil to fans
- Fan speed is thermostatically controlled
- Extremely high cooling efficiency to ensure optimum oil temperature

## Swing System

Swing drives	2 compact planetary transmissions with axial piston motors
Parking brakes	Wet multiple-disc brake, spring-loaded/hydraulically released
Maximum swing speed	
Diesel version	4.6 rpm
AC version	5.0 rpm
Swing ring	Triple-race roller bearing with sealed internal gearing

- Closed-loop swing circuit with torque control
- Hydraulic braking of the swing motion by counteracting control
- All raceways of swing ring as well as grease bath for internal gearing supplied by automatic, central lubrication system

## Retractable Service Station

Retractable service station installed underneath the engine module and easily accessible from ground.

Equipped with:

- Quick couplings for:
  - Diesel fuel
  - Engine coolant – left/right
  - Pump transmission gear oil – left/right
  - Engine oil – left/right
  - Hydraulic oil tank
  - Grease container
- Cat jump-start socket
- Indicator lights for fuel tanks left/right full and grease container full

# 6030/6030 FS Hydraulic Shovel Specifications

## Operator's Cab

Operator's eye level – approximately	6.5 m	21 ft 4 in
Internal dimensions of cab		
Length	2200 mm	7 ft 3 in
Width	1600 mm	5 ft 3 in
Height	2150 mm	7 ft 1 in

- Under roof mounted heating ventilating and air conditioning system
- Pneumatically cushioned and multi-adjustable comfort seat with lumbar support, seat heating, safety belt, head- and armrests
- Switch in seat cushion to automatically neutralize the hydraulic controls when operator leaves the seat
- Joystick controls integrated in independently adjustable seat consoles
- Fold-away auxiliary seat with safety belt
- FOPS (rock guard; approved according to DIN ISO 3449) integrated into cab structure
- All-round safety glass, armored windshield and sliding side window
- Windshield with parallel intermittent wiper/washer
- Roller blinds at all windows
- External sun shields at side and rear windows
- Robust instrument panel including large colored BCS screen with transfective technology
- Board Control System (BCS) electronic monitoring and data logging system for vital signs and service data of engines, hydraulic system and lubrication system
- Machine access via retractable access stairway, stairway angle approximately 45°, hydraulically operated
- Sliding emergency ladder (kick-down type) with ladder cage

## Undercarriage

Travel speed (2 stages)		
1st stage – maximum	1.4 km/h	0.87 mph
2nd stage – maximum	2.7 km/h	1.68 mph
Maximum tractive force	1637 kN	367,880 lbf
Gradeability of travel drives – approximate	64%	
Track pads (each side)	47	
Bottom rollers (each side)	7	
Support rollers (each side)	2 plus a skid plate in between	
Travel drives (each side)	1 planetary transmission with 2 two-stage axial piston motors	
Parking brakes	Wet multiple disc brake, spring loaded/hydraulically released	

- Cast double-grouser combined pad-links with bushings connected by hardened full floating pins
- All running surfaces of sprockets, idlers, rollers and pad links, as well as teeth contact areas of sprocket and pad links, are hardened
- Fully hydraulic self-adjusting track tensioning system with membrane accumulator
- Automatic hydraulic retarder valve to prevent over-speed on downhill travel
- Acoustic travel alarm

## Automatic Lubrication System

Capacity of grease container	450 L	120 gal
------------------------------	-------	---------

- Dual-circuit system with hydraulically driven heavy-duty pump and electronic time relay control to adjust the pause/lube times
- Connected to the lubrication system are the swing roller bearing with internal gearing and all pivot points of attachment, bucket and cylinders
- Lubricated pinion for greasing of internal gearing of swing ring
- System failures displayed by Board Control System
- Grease filters (200 µm) between service station and container as well as directly behind grease pump

## Attachments

- Booms and sticks are torsion-resistant, welded box design of high-tensile steel with solid steel castings at pivot areas
- Welding procedures allow for internal counter-welding (double prep weld) wherever possible
- Booms and sticks are stress-relieved after welding
- Catwalks with rails at booms
- Pressure-free lowering of boom (FS and BH) and stick (FS) by means of a float valve
- Shovel attachment with unique TriPower kinematics ensuring the following main features:
  - Horizontal automatic constant-angle bucket guidance
  - Vertical automatic constant-angle bucket guidance
  - Automatic roll-back limiter to prevent material spillage
  - Kinematic assistance to hydraulic forces
  - Constant boom momentum throughout the whole lift arc
  - Crowd force assistance
- All buckets (FS and BH) are equipped with a wear package consisting of:
  - Special liner material covering main wear areas inside and outside of bucket
  - Lip shrouds between teeth
  - Wing shrouds on side walls
  - Heel shrouds at bottom edges
- Special wear packages for highly abrasive materials on request

# 6030/6030 FS Hydraulic Shovel Specifications

## Dimensions

All dimensions are approximate.

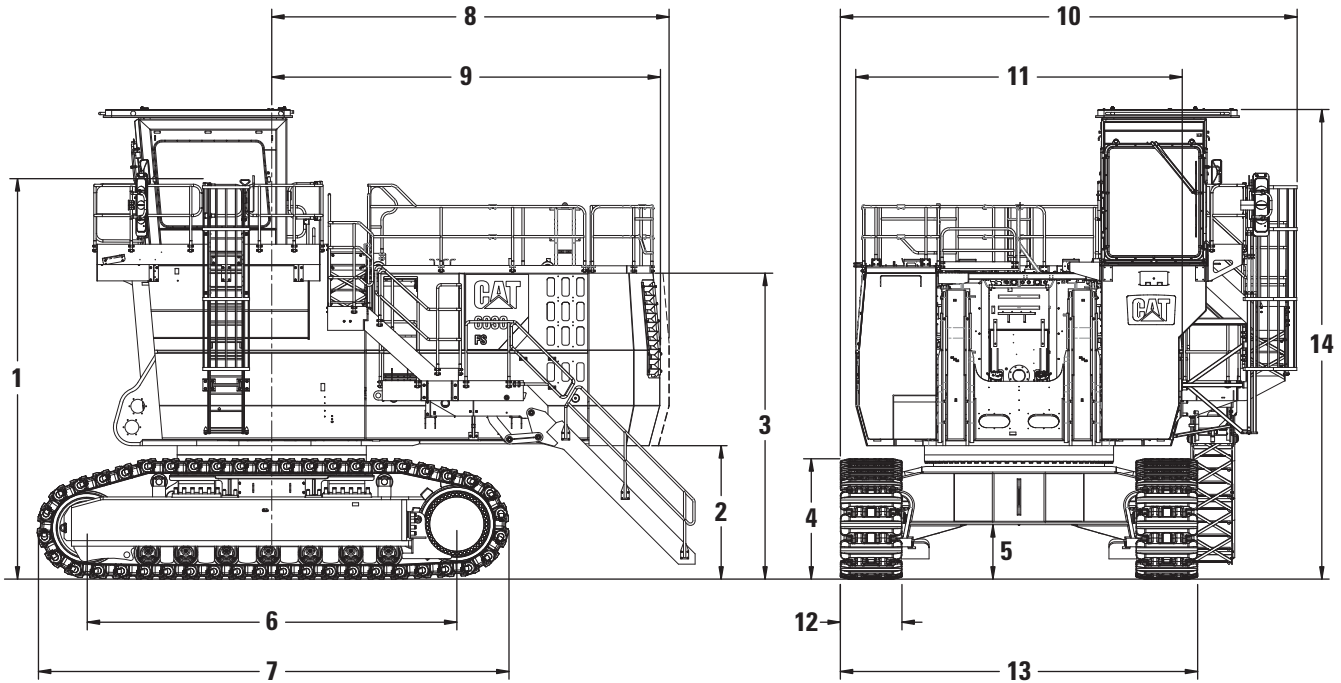

<b>1</b>	6500 mm	21 ft 4 in	<b>8</b>	6450 mm	21 ft 2 in
<b>2</b>	2170 mm	7 ft 1 in	<b>9</b>	6310 mm	20 ft 8 in
<b>3</b>	4970 mm	16 ft 4 in	<b>10</b>	7420 mm	24 ft 4 in
<b>4</b>	1940 mm	6 ft 4 in	<b>11</b>	5300 mm	17 ft 5 in
<b>5</b>	880 mm	2 ft 11 in	<b>12</b>	1000 mm	3 ft 3 in
<b>6</b>	6010 mm	19 ft 9 in	<b>13</b>	5800 mm	19 ft 0 in
<b>7</b>	7660 mm	25 ft 2 in	<b>14</b>	7620 mm	25 ft 0 in

Dimensions and weights of AC machine differ slightly. Separate drawings, dimensions and weights can be provided upon request.

# 6030/6030 FS Hydraulic Shovel Specifications

## Working Range – TriPower Face Shovel Attachment (FS)

All dimensions are approximate.

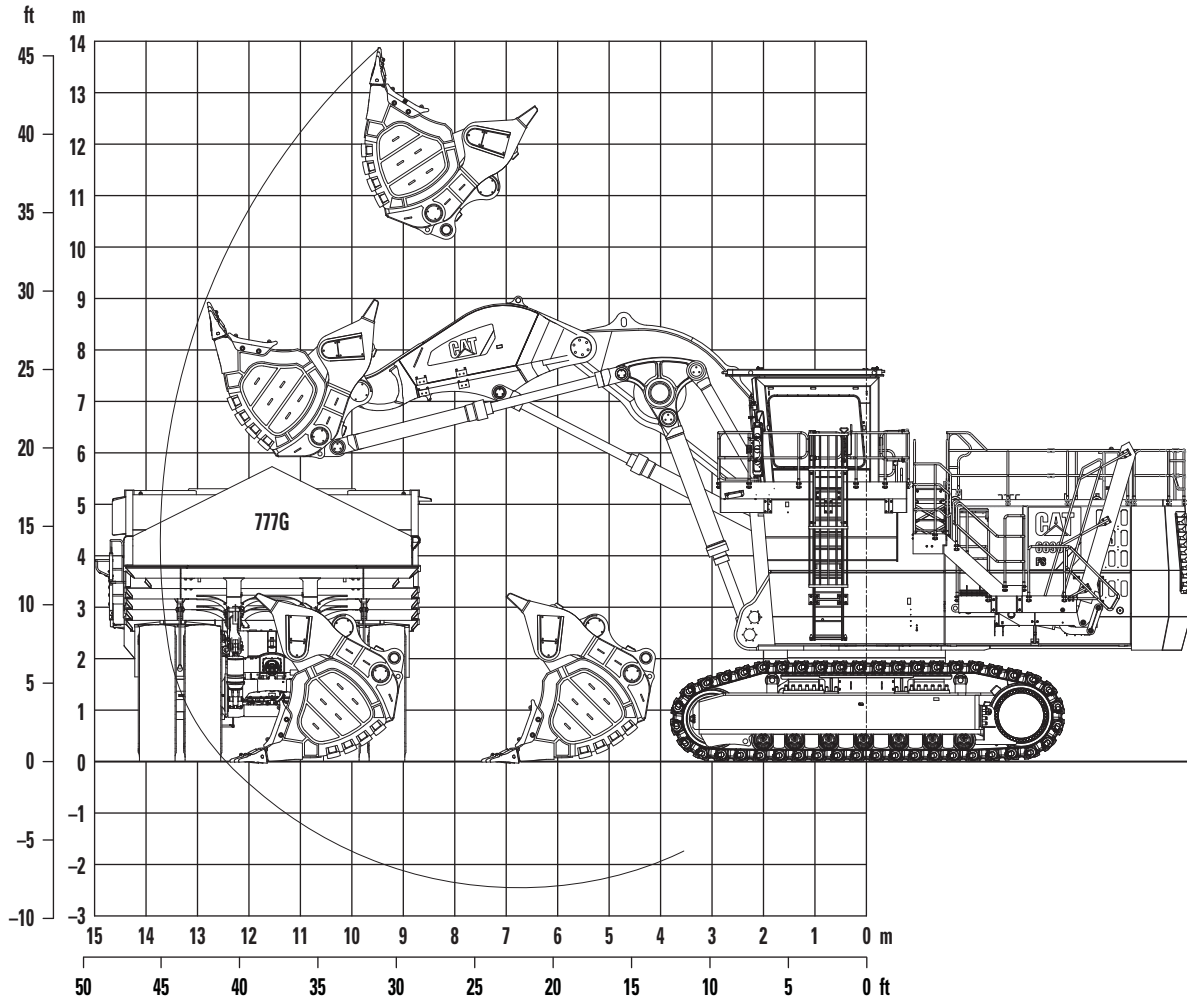

<b>Boom</b>	<b>6.2 m</b>	<b>20 ft 4 in</b>	<b>Working Range</b>	
<b>Stick</b>	<b>4.4 m</b>	<b>14 ft 5 in</b>	Maximum digging height	13.9 m 45 ft 7 in
<b>Digging Forces (ISO)</b>			Maximum digging reach	13.7 m 44 ft 11 in
Maximum crowd force	1298 kN	291,700 lbf	Maximum digging depth	2.5 m 8 ft 2 in
Maximum crowd force at ground level	1215 kN	273,050 lbf	Maximum dumping height	10.7 m 35 ft 1 in
Maximum breakout force	954 kN	241,390 lbf	Crowd distance on level	4.9 m 16 ft 1 in

### Face Shovels

Type	Iron Ore Shovel		Heavy Rock Shovel		Heavy Rock Shovel		Standard Rock Shovel	
Capacity heaped 2:1 (ISO 7546)	12.0 m <sup>3</sup>	15.7 yd <sup>3</sup>	13.5 m <sup>3</sup>	17.7 yd <sup>3</sup>	15.0 m <sup>3</sup>	19.6 yd <sup>3</sup>	16.5 m <sup>3</sup>	21.6 yd <sup>3</sup>
Total width	3930 mm	12 ft 11 in	3930 mm	12 ft 11 in	3930 mm	12 ft 11 in	3930 mm	12 ft 11 in
Inner width	3500 mm	11 ft 6 in	3500 mm	11 ft 6 in	3500 mm	11 ft 6 in	3500 mm	11 ft 6 in
Opening width	1790 mm	5 ft 10 in	1790 mm	5 ft 10 in	1790 mm	5 ft 10 in	1790 mm	5 ft 10 in
Number of teeth	6		6		6		6	
Weight including wear package and standard penetration tips	25 900 kg	57,100 lb	26 800 kg	59,080 lb	27 100 kg	57,740 lb	27 400 kg	60,410 lb
Maximum material density (loose)	2.6 t/m <sup>3</sup>	4,380 lb/yd <sup>3</sup>	2.2 t/m <sup>3</sup>	3,710 lb/yd <sup>3</sup>	2.0 t/m <sup>3</sup>	3,370 lb/yd <sup>3</sup>	1.8 t/m <sup>3</sup>	3,030 lb/yd <sup>3</sup>

# 6030/6030 FS Hydraulic Shovel Specifications

## Working Range – Backhoe Attachment (BH)

All dimensions are approximate.

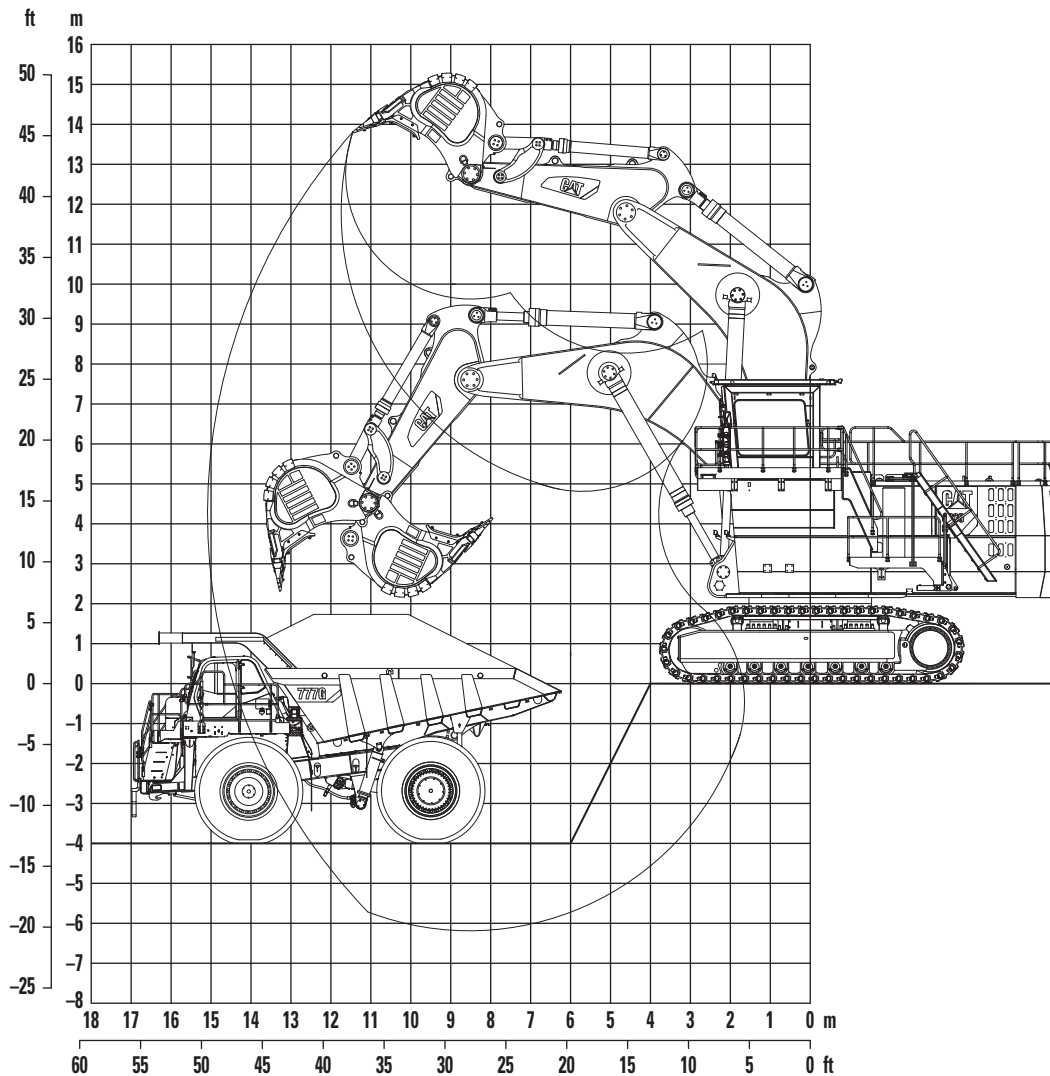

<b>Boom</b>	<b>8.5 m</b>	<b>27 ft 11 in</b>	<b>Working Range</b>	
<b>Stick</b>	<b>4.0 m</b>	<b>13 ft 1 in</b>	Maximum digging depth	6.2 m 20 ft 4 in
<b>Digging Forces (ISO)</b>			Maximum digging reach	15.1 m 49 ft 6 in
Maximum tearout force	944 kN	212,150 lbf	Maximum digging height	13.8 m 45 ft 3 in
Maximum breakout force	880 kN	197,760 lbf		

### Backhoes

Type	Iron Ore Bucket		Heavy Rock Bucket		Standard Rock Bucket		Light Rock Bucket	
Capacity heaped 1:1 (ISO 7451)	12.0 m <sup>3</sup>	15.7 yd <sup>3</sup>	15.0 m <sup>3</sup>	19.6 yd <sup>3</sup>	17.0 m <sup>3</sup>	22.2 yd <sup>3</sup>	18.0 m <sup>3</sup>	23.5 yd <sup>3</sup>
Total width	3520 mm	11 ft 7 in	3950 mm	13 ft 0 in	4240 mm	13 ft 2 in	4360 mm	14 ft 4 in
Inner width	3000 mm	9 ft 10 in	3430 mm	11 ft 3 in	3730 mm	12 ft 3 in	3930 mm	12 ft 11 in
Number of teeth	5		5		6		6	
Weight including wear package and standard penetration tips	15 500 kg	34,170 lb	17 100 kg	37,700 lb	18 300 kg	40,340 lb	19 200 kg	42,330 lb
Maximum material density (loose)	2.6 t/m <sup>3</sup>	4,380 lb/yd <sup>3</sup>	2.0 t/m <sup>3</sup>	3,370 lb/yd <sup>3</sup>	1.8 t/m <sup>3</sup>	3,030 lb/yd <sup>3</sup>	1.65 t/m <sup>3</sup>	2,780 lb/yd <sup>3</sup>

# 6030/6030 FS Optional Equipment

## Optional Equipment

Optional equipment may vary. Consult your Cat dealer for details.

### GENERAL

- Export crating
- Custom paint

### SUPERSTRUCTURE

- C27 ACERT engines meet U.S. EPA Tier 4 Interim equivalent emission standards
- Oil change interval extension for engine oil up to 1,000 hours
- Hydraulic service crane on superstructure with auxiliary engine
- Round container for a standard 200 L (53 gal) grease barrel (instead of 450 L (119 gal) grease container)
- Cold-weather package

### CAB

- Cab heating
- Dual (redundancy) HVAC system
- Camera monitoring system
- Windshield guard (FOGS)

### UNDERCARRIAGE

- Track pad width 800 mm (2 ft 7 in) or 1200 mm (3 ft 11 in)
- Cover plate under carbody (belly plate)

Additional optional equipment available on request.



For more complete information on Cat products, dealer services, and industry solutions, visit us on the web at [www.cat.com](http://www.cat.com)

AEHQ6967-02 (08-2016)  
Replaces AEHQ6967-01

© 2016 Caterpillar  
All rights reserved

Materials and specifications are subject to change without notice. Featured machines in photos may include additional equipment. See your Cat dealer for available options.

CAT, CATERPILLAR, SAFETY.CAT.COM, their respective logos, "Caterpillar Yellow" and the "Power Edge" trade dress, as well as corporate and product identity used herein, are trademarks of Caterpillar and may not be used without permission.

