

Shown with  
Accessory Equipment

### SPECIFICATIONS

#### V-12, 4-Stroke-Cycle-Diesel

Emissions	IMO II/EPA Tier 2 compliant
Displacement	222 L (13,546 cu. in.)
Low Idle Speed	350 rpm
Rated Speed	1000 rpm
Bore	280 mm (11.0 in.)
Stroke	300 mm (11.8 in.)
Compression Ratio	13:1
Aspiration	Turbocharged-Aftercooled Governor
Cooling System	Keel or Heat Exchanger
Weight, Dry	25,980 kg (57,276 lbs)
Refill Capacities	
Cooling System	1400-1575 L (370-416 gal)
Lube Oil System	910 L (240 gal)
Oil Change Interval*	750 hours
Rotation (from flywheel end)	CCW or CW
Serial Number Prefix	TSJ

\*A new S•O•S<sup>SM</sup> analysis must be done to determine actual oil change intervals.

### STANDARD ENGINE EQUIPMENT

#### Air Intake and Exhaust System

Charge air cooler, air inlet shutoff, high flow turbocharger, dry manifold with soft or hard shielding

#### Basic Engine Arrangement

Vee engine with one-piece grey iron cylinder block, individual cylinder heads with four intake/exhaust valves, right- or left-hand service side available

#### Control System

Dual ADEM™ A3 electronic engine control unit (ECU) with electronic unit injector fuel system, rigid wiring harness (10 amp, 24 volt power required to drive ECU)

#### Cooling System

Single or combined system, engine mounted freshwater and seawater pumps, engine coolant water drains

#### Fuel System

Engine operates on MDO; fuel injection system consists of engine-driven fuel transfer pump and an electronic unit injector for each cylinder, engine-mounted duplex fuel filters, and flexible connections

#### Lube Oil System

Top-mounted crankcase breather, three centrifugal oil filters with single shutoff, gear-driven pump, duplex oil filter, crankcase explosion relief, oil filler and dipstick

#### Monitoring, Alarm, and Safety Control System

Alarms and shutdowns provided as required by marine society for unmanned machinery spaces. Marine Monitoring System II [listed as Programmable Logic Control (PLC) in the Price List] or Engine Control Panel are available; systems include temperature, pressure, and speed sensors; optional: oil mist detector or particle detector available

#### ECU Functions

Key-switch, desired engine speed, programmable low idle, SAE J1939 data link, Cat® data link, Messenger (displays engine data, diagnostics, etc.), diagnostics, general alarm, programmable parameters (system, application, and tattletales), Cat ET service tool interface, remote shutdown, shutdown notify, load feedback, overspeed shutdown, overspeed verify, engine power correction, droop, dual dynamics

#### General

Four lifting eyes mounted to cylinder heads, Cat yellow paint, parts books and maintenance manuals, shrink wrap

#### Optional Supplied Equipment

Torsional coupling, fresh water heat exchanger, fuel cooler, expansion tank, emergency pumps and connections, jacket water heater, flexible connections, and anti-vibration isolators

### MARINE ENGINE PERFORMANCE

# C280-12

## DIESEL ENGINE TECHNICAL DATA



RATED SPEED (RPM): 1000  
 RATED POWER<sup>1</sup> (bkW): 3700  
 BMEP @ 100% LOAD (kPa): 2003  
 COMPRESSION RATIO: 13:1  
 AFTERCOOLER WATER (°C): 32  
 JACKET WATER OUTLET (°C): 90  
 IGNITION SYSTEM: EUI  
 FIRING PRESSURE, MAXIMUM (kPa): 16200

ENGINE RATING: **Marine CSR**  
 CERTIFICATION<sup>2</sup>: IMO II/EPA MARINE TIER II  
 TURBOCHARGER PART #: 189-4427  
 COMBUSTION: DI  
 FUEL TYPE: Distillate  
 EXHAUST MANIFOLD: DRY  
 MEAN PISTON SPEED (m/s): 10

### Engine Performance

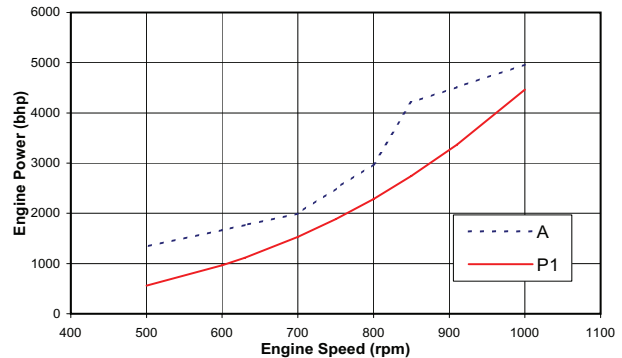
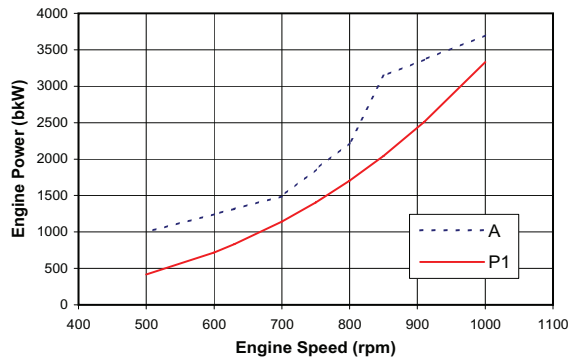

ZONE LIMIT DATA									
Engine Speed rpm	Power bkW	Fuel Cons <sup>3</sup> g/ kW-hr	Fuel Rate L/hr	Boost Press kPa Gauge	Air Flow <sup>4</sup> cu m/ min	Exh Temp to Turbo C	Exh Stack Temp C	Exh Flow cu m/ min	Exh Flow cfm
1000	3700	204	899.7	224	340.9	523	374	732.7	
910	3366	206	826.6	214	307.2	536	392	678.9	
850	3144	201	753.4	184	259.9	548	445	621.8	
800	2220	208	550.4	106	171.3	533	443	410.1	
750	1856	210	464.6	74	136.7	522	433	323.4	
700	1490	210	373.0	55	111.4	504	447	268.6	
630	1318	217	340.9	47	96.2	507	457	235.7	
600	1246	216	320.8	45	90.3	510	464	223.4	
500	1000	222	264.6	37	92.8	496	463	227.5	

ZONE LIMIT DATA									
Engine Speed rpm	Power bhp	Fuel Cons <sup>3</sup> lb/ hp-hr	Fuel Rate gal/hr	Boost Press in Hg-Gauge	Air Flow <sup>4</sup> cu ft/ min	Exh Temp to Turbo F	Exh Stack Temp F	Exh Flow cu m/ min	Exh Flow cfm
1000	4962	0.336	237.6	66	12040	973	705	25876	
910	4514	0.339	218.3	63	10848	997	738	23977	
850	4217	0.331	198.9	55	9179	1018	833	21957	
800	2977	0.342	145.3	31	6050	991	829	14483	
750	2489	0.346	122.7	22	4828	972	811	11421	
700	1998	0.346	98.5	16	3934	939	837	9485	
630	1767	0.357	90.0	14	3397	945	855	8324	
600	1671	0.356	84.7	13	3189	950	867	7888	
500	1341	0.366	69.9	11	3278	925	865	8034	

PROPELLER DEMAND DATA									
Engine Speed rpm	Power bkW	Fuel Cons <sup>3</sup> g/ kW-hr	Fuel Rate L/hr	Boost Press kPa Gauge	Air Flow <sup>4</sup> cu m/ min	Exh Temp to Turbo C	Exh Stack Temp C	Exh Flow cu m/ min	Exh Flow cfm
1000	3330	209	829.6	210	335.9	510	368	713.8	
910	2509	210	628.2	145	249.8	508	393	551.8	
850	2045	212	516.8	98	192.4	505	421	443.8	
800	1705	208	422.7	70	160.3	494	428	373.3	
750	1405	212	355.0	51	131.6	472	415	301.1	
700	1142	214	291.4	38	114.8	451	408	259.3	
630	833	218	216.4	25	84.4	412	375	181.5	
600	719	224	192.1	18	77.6	390	360	162.9	
500	416	225	111.6	12	67.5	318	293	125.5	

PROPELLER DEMAND DATA									
Engine Speed rpm	Power bhp	Fuel Cons <sup>3</sup> lb/ hp-hr	Fuel Rate gal/hr	Boost Press in Hg-Gauge	Air Flow <sup>4</sup> cu ft/ min	Exh Temp to Turbo F	Exh Stack Temp F	Exh Flow cu m/ min	Exh Flow cfm
1000	4466	0.344	219.0	62	11861	950	694	25207	
910	3365	0.346	165.9	43	8821	946	739	19488	
850	2742	0.349	136.5	29	6795	941	790	15673	
800	2286	0.342	111.6	21	5662	921	802	13185	
750	1884	0.349	93.7	15	4649	882	779	10632	
700	1532	0.352	76.9	11	4053	844	766	9158	
630	1117	0.359	57.1	7	2980	774	707	6409	
600	965	0.369	50.7	5	2742	734	680	5754	
500	558	0.370	29.5	4	2384	604	559	4432	

### Heat Rejection @ 100% Load and 25° C Air

Lube Oil Cooler	kW ( Btu/min )	377 ( 21451 )
Jacket Water	kW ( Btu/min )	758 ( 43130 )
AfterCooler	kW ( Btu/min )	1188 ( 67597 )
Total Heat Rejection to Raw Water	kW ( Btu/min )	2323 ( 132179 )
Exhaust Gas <sup>2</sup>	kW ( Btu/min )	2768 ( 157499 )
Radiation	kW ( Btu/min )	179 ( 10185 )

### Notes

- 1 Ratings are based on ISO 3046/1 and SAE J1995 Jan 90 standard reference conditions of 100 kPa, 25° C, and 30% relative humidity at the stated aftercooler water temperature.
- 2 Exhaust Heat rejection is based on fuel LHV and is not normally recoverable in total
- 3 At 100% load with JW and oil pumps, without seawater pump, +/- 3%. Performance and fuel consumption are based on 35 API, 16°C fuel having a lower heating value of 42,780 kJ/kg used at 29°C with a density of 838.9 g/liter.
- 4 Air flows are shown for 25°C air inlet to the turbocharger and 32°C cooling water to the charge air cooler.
- 5 This engine's exhaust emissions are in compliance with the INTERNATIONAL MARINE ORGANIZATION'S (IMO) standard as described in REGULATION 13 of ANNEX VI of MARPOL 73/78 and ISO 8178 for measuring HC, CO, PM, and NOx.

### ENGINE DIMENSIONS

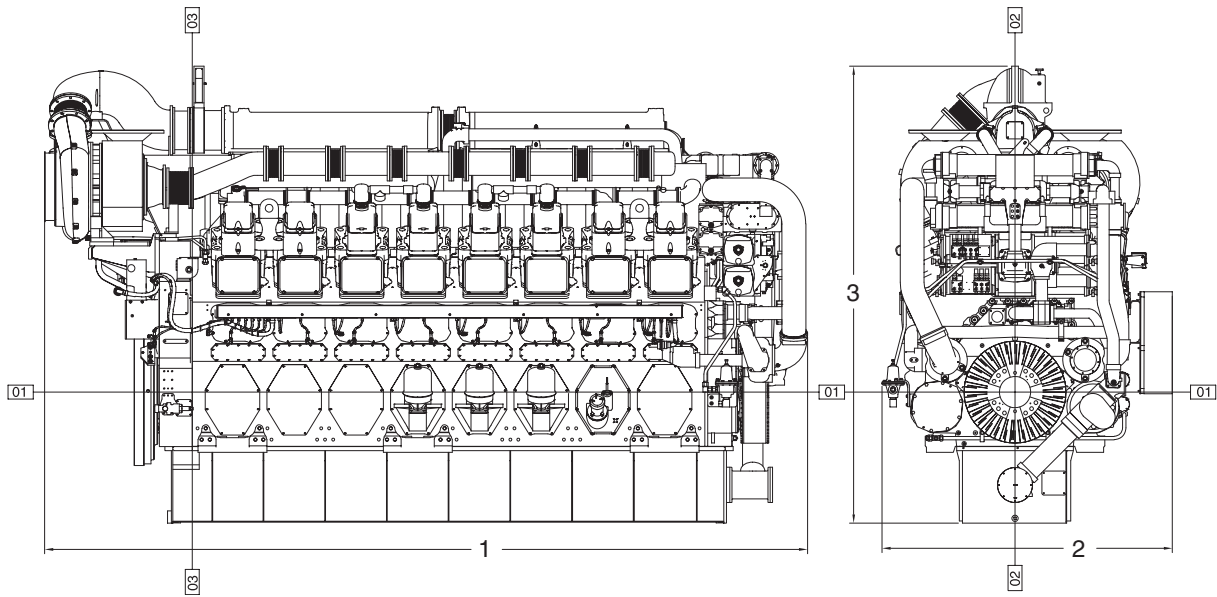

Engine Dimensions		
(1) Overall Length	4612 mm	181.6 in.
(2) Overall Width	2022 mm	79.6 in.
(3) Overall Height	3404 mm	134.0 in.

Note: Do not use for installation design. See general dimension drawings for detail.

Engine Weights		
<b>Engine Dry Weight</b>	25,980 kg	57,276 lb
<b>Shipped Loose Items</b>		
Torsional Coupling	420 kg	926 lb
Plate-Type Heat Exchanger	450 kg	990 lb
Instrument/Alarm Panel	200 kg	440 lb
<b>Fluids</b>		
Lube Oil	828 kg	1,825 lb
Jacket Water	800 kg	1,764 lb
Heat Exchanger (FW, SW, LO)	80 kg	176 lb

## RATING DEFINITIONS AND CONDITIONS

---

**Continuous Service Rating** — 100% of the engine operating hours at 100% of rated power.

**Ratings** are based on SAE J1995/ISO3046 standard conditions of 100 kPa (29.61 in. Hg), 25°C (77°F), and 30% relative humidity at the stated charge air cooler water temperature. Ratings also meet classification society maximum temperature requirements of 45°C (113°F) air temperature to the turbocharger and 32°C (90°F) seawater temperature without derate.

Additional ratings may be available for specific customer requirements. Consult your Cat representative for additional information.

**Fuel rates** are based on 35° API, 16°C (60°F) fuel used at 29°C (85°F) with a density of 838.9 g/liter (7.001 lbs/U.S. gal). Lower Heat Value (LHV) of 42 780 kJ/kg (18,390 Btu/lb). Tolerance is +5%. Includes all engine mounted pumps. BSFC without pumps is 3% less.

**Marine Certification** — Ratings are marine classification society approved by ABS, BV, CCS, DnV, GL, KR, LRS, NKK, RINA, and RS. These societies have also granted C280 factory line production approval which eliminates requirement for society surveyor witness test.

Performance data is calculated in accordance with tolerances and conditions stated in this specification sheet and is only intended for purposes of comparison with other manufacturers' engines. Actual engine performance may vary according to the particular application of the engine and operating conditions beyond Caterpillar's control.

Power produced at the flywheel will be within standard tolerances up to 49°C (120°F) combustion air temperature measured at the air cleaner inlet, and fuel temperature up to 52°C (125°F) measured at the fuel filter base. Power rated in accordance with NMMA procedure as crankshaft power. Reduce crankshaft power by 3% for propeller shaft power.

CAT, CATERPILLAR, their respective logos, ADEM, S•O•S, "Caterpillar Yellow" and the "Power Edge" trade dress, as well as corporate and product identity used herein, are trademarks of Caterpillar and may not be used without permission.