

May not represent actual engine

SPECIFICATIONS

V-16, 4-Stroke-Cycle-Diesel

Emissions	IMO II/EPA Tier 2 Compliant
Bore	280 mm (11.0 in.)
Stroke	300 mm (11.8 in.)
Displacement	296 L (18,062 cu. in.)
Rotation (from flywheel end)	Counterclockwise
Compression Ratio	13:1
Aspiration	Turbocharged-Aftercooled
Governor	Electronic
Low Idle Speed	350 rpm
Rated Speed	1000 rpm
Oil Change Interval*	600 hr
Serial Number Prefix	NKB
Cooling System	Keel or Heat Exchanger
Refill Capacities	
Cooling System	1660-1835 L (439-485 gal)
Lube Oil System	1057 L (279 gal)

*A new S•O•SSM analysis must be done to determine actual oil change intervals.

STANDARD ENGINE EQUIPMENT

Air Inlet System

Aftercooler — fresh water, corrosion resistant coated (air side); air inlet shutoff; breather — crankcase, top-mounted; turbocharger — engine oil lubricated

Control System

Single ADEM™ A3 electronic control unit (ECU) with electronic unit injector fuel system, rigid wiring harness (10 amp, 24 volt power required to drive ECUs)

Cooling System

Engine coolant water drains

Exhaust System

Dry, gas tight, exhaust manifold

Fuel System

Distillate fuel (requires viscosity ranging from 1.4 cSt to 20 cSt at 38° C), fuel transfer pump (mounted on left-hand side), duplex fuel filters, electronically controlled unit injectors

Lube Oil System

Centrifugal oil filters with single shutoff, service side engine mounted on cylinder block inspection covers includes installed oil lines and single shutoff valve, filters centrifuge bypass oil from the main lubricating oil pump, can be serviced with the engine running, oil filler and dipstick valve, oil pressure regulating valves, crankcase explosion relief valves

General

Cat® yellow paint; gear-driven pumps: fuel, oil, jacket water, aftercooler/oil cooler water; service literature

Factory-designed systems built at Caterpillar ISO 9001:2000 certified facilities.

MARINE ENGINE PERFORMANCE

C280-16		DIESEL ENGINE TECHNICAL DATA		CATERPILLAR®			
Genset	50 Hz	RATING:	Marine Aux - Prime				
ENGINE SPEED (rpm):	1000	CERTIFICATION:	IMO II/EPA MARINE TIER II				
COMPRESSION RATIO:	13:1	TURBOCHARGER PART #:	284-8277				
AFTERCOOLER WATER (°C):	32	FUEL TYPE:	Distillate				
JACKET WATER INLET (°C):	90	RATED ALTITUDE @ 25°C (m):	150				
IGNITION SYSTEM:	EUI	ASSUMED GENERATOR EFFICIENCY (%):	96				
EXHAUST MANIFOLD:	DRY	ASSUMED GENERATOR POWER FACTOR:	0.8				
FIRING PRESSURE, MAXIMUM (kPa)	17300	MEAN PISTON SPEED (m/s):	10				
RATING		NOTES	LOAD	110%	100%	75%	50%
ENGINE POWER		(2)	bkW	5962	5420	4065	2710
GENERATOR POWER		(2)	ekW	5720	5200	3900	2600
BMEP			kPa	2421	2201	1651	1101
ENGINE EFFICIENCY	(ISO 3046/1)	(1)	%	44.7%	44.1%	41.6%	39.4%
ENGINE EFFICIENCY	(NOMINAL)	(1)	%	43.4%	42.8%	40.3%	38.2%
ENGINE DATA							
FUEL CONSUMPTION	(ISO 3046/1)	(1)	g/bkW-hr	189.0	191.6	203.5	214.8
FUEL CONSUMPTION	(NOMINAL)	(1)	g/bkW-hr	192.7	195.3	207.5	219.0
FUEL CONSUMPTION	(90% CONFIDENCE)	(1)	g/bkW-hr	194.8	197.5	210.0	221.7
AIR FLOW (@ 25°C, 101.3 kPaa)			Nm ³ /min	620.5	566.2	470.2	306.3
AIR MASS FLOW			kg/hr	41530	37895	31472	20497
INLET MANIFOLD PRESSURE			kPa (abs)	405.0	365.3	303.3	198.2
INLET MANIFOLD TEMPERATURE			°C	44.6	44.2	43.3	42.2
EXHAUST STACK TEMPERATURE			°C	356.5	362.5	382.0	444.6
EXHAUST GAS FLOW (@ stack temp, 101.3 kPa)			m ³ /min	1332.1	1209.0	984.6	641.4
EXHAUST GAS MASS FLOW			kg/hr	42680	38954	32316	21091
EMISSIONS "NOT TO EXCEED DATA"							
Nox as NO ₂ + THC (molecular weight of 13.018)			g/bkW-hr	11.03	11.66	10.47	9.57
Nox as NO ₂			g/bkW-hr	9.56	10.55	9.46	8.26
CO			g/bkW-hr	0.85	0.79	0.68	1.26
THC (molecular weight of 13.018)			g/bkW-hr	1.47	1.11	1.01	1.31
Particulates			g/bkW-hr	0.31	0.28	0.25	0.39
EMISSIONS "NOMINAL DATA"							
NO _x (as NO) + THC (molecular weight of 13.018)			g/bkW-hr	9.44	10.03	9.00	8.19
NO _x (as NO)			g/bkW-hr	8.31	9.18	8.22	7.18
CO			g/bkW-hr	0.65	0.61	0.52	0.97
THC (molecular weight of 13.018)			g/bkW-hr	1.13	0.86	0.78	1.01
Particulates			g/bkW-hr	0.22	0.20	0.18	0.28
ENERGY BALANCE DATA							
FUEL INPUT ENERGY (LHV)	(NOMINAL)	(1)	KW	13736	12659	10079	7096
HEAT REJ. TO JACKET WATER	(NOMINAL)	(3)	KW	1164	1079	881	687
HEAT REJ. TO ATMOSPHERE	(NOMINAL)	(4)	KW	275	253	202	142
HEAT REJ. TO OIL COOLER	(NOMINAL)	(5)	KW	598	569	503	437
HEAT REJ. TO EXH. (LHV to 25°C)	(NOMINAL)	(3)	KW	4020	3833	3394	2683
HEAT REJ. TO EXH. (LHV to 177°C)	(NOMINAL)	(3)	KW	3405	3140	2516	1524
HEAT REJ. TO AFTERCOOLER	(NOMINAL)	(6) (7)	KW	1681	1472	1011	419
CONDITIONS AND DEFINITIONS							
ENGINE RATING OBTAINED AND PRESENTED IN ACCORDANCE WITH ISO 3046/1 AND SAE J1995 JAN90 STANDARD REFERENCE CONDITIONS OF 25°C, 100 KPA, 30% RELATIVE HUMIDITY AND 150M ALTITUDE AT THE STATED AFTERCOOLER WATER TEMPERATURE.							
CONSULT ALTITUDE CURVES FOR APPLICATIONS ABOVE MAXIMUM RATED ALTITUDE AND/OR TEMPERATURE.							
PERFORMANCE AND FUEL CONSUMPTION ARE BASED ON 35 API, 16°C FUEL HAVING A LOWER HEATING VALUE OF 42.780 KJ/KG USED AT 29°C WITH A DENSITY OF 838.9 G/LITER.							
NOTES							
1) FUEL CONSUMPTION TOLERANCE. ISO 3046/1 IS 0, + 5% OF FULL LOAD DATA. NOMINAL IS ± 3 % OF FULL LOAD DATA.							
2) ENGINE POWER TOLERANCE IS ± 3 % OF FULL LOAD DATA.							
3) HEAT REJECTION TO JACKET AND EXHAUST TOLERANCE IS ± 10% OF FULL LOAD DATA. (heat rate based on treated water)							
4) HEAT REJECTION TO ATMOSPHERE TOLERANCE IS ±50% OF FULL LOAD DATA. (heat rate based on treated water)							
5) HEAT REJECTION TO LUBE OIL TOLERANCE IS ± 20% OF FULL LOAD DATA. (heat rate based on treated water)							
6) HEAT REJECTION TO AFTERCOOLER TOLERANCE IS ± 5% OF FULL LOAD DATA. (heat rate based on treated water)							
7) TOTAL AFTERCOOLER HEAT = AFTERCOOLER HEAT x ACHRF (heat rate based on treated water)							
8) FUEL CONSUMPTION DATA IS WITHOUT SEA WATER PUMP.							
4/4/2010				DM8417 - 02			

MARINE ENGINE PERFORMANCE

C280-16

DIESEL ENGINE TECHNICAL DATA



ALTITUDE DERATION FACTORS

AIR TO TURBO (°C)	50	0.94	0.91	0.88	0.86	0.83	0.81	0.78	0.76	0.74	0.71	0.69	0.67	0.65
	45	0.95	0.93	0.90	0.87	0.85	0.82	0.80	0.77	0.75	0.73	0.70	0.68	0.66
	40	0.97	0.94	0.91	0.89	0.86	0.83	0.81	0.78	0.76	0.74	0.71	0.69	0.67
	35	0.98	0.96	0.93	0.90	0.87	0.85	0.82	0.80	0.77	0.75	0.73	0.70	0.68
	30	1.00	0.97	0.94	0.92	0.89	0.86	0.84	0.81	0.79	0.76	0.74	0.71	0.69
	25	1.00	0.99	0.96	0.93	0.90	0.88	0.85	0.82	0.80	0.77	0.75	0.73	0.70
	20	1.00	1.00	0.98	0.95	0.92	0.89	0.86	0.84	0.81	0.79	0.76	0.74	0.72
	15	1.00	1.00	0.99	0.96	0.93	0.91	0.88	0.85	0.83	0.80	0.78	0.75	0.73
	10	1.00	1.00	1.00	0.98	0.95	0.92	0.89	0.87	0.84	0.82	0.79	0.77	0.74
			0	250	500	750	1000	1250	1500	1750	2000	2250	2500	2750

ALTITUDE (METERS ABOVE SEA LEVEL)

AFTERCOOLER HEAT REJECTION FACTORS

AIR TO TURBO (°C)	50	1.23	1.27	1.30	1.34	1.38	1.42	1.45	1.49	1.53	1.56	1.60	1.64	1.67
	45	1.18	1.22	1.25	1.29	1.32	1.36	1.39	1.43	1.46	1.50	1.53	1.57	1.61
	40	1.13	1.17	1.20	1.23	1.27	1.30	1.34	1.37	1.40	1.44	1.47	1.50	1.54
	35	1.08	1.12	1.15	1.18	1.21	1.24	1.28	1.31	1.34	1.37	1.41	1.44	1.47
	30	1.03	1.06	1.10	1.13	1.16	1.19	1.22	1.25	1.28	1.31	1.34	1.37	1.40
	25	1.00	1.01	1.04	1.07	1.10	1.13	1.16	1.19	1.22	1.25	1.28	1.31	1.34
	20	1.00	1.00	1.00	1.02	1.05	1.07	1.10	1.13	1.16	1.19	1.21	1.24	1.27
	15	1.00	1.00	1.00	1.00	1.00	1.02	1.04	1.07	1.10	1.12	1.15	1.18	1.20
	10	1.00	1.00	1.00	1.00	1.00	1.00	1.00	1.01	1.04	1.06	1.09	1.11	1.14
			0	250	500	750	1000	1250	1500	1750	2000	2250	2500	2750

ALTITUDE (METERS ABOVE SEA LEVEL)

FREE FIELD MECHANICAL NOISE

		SOUND PRESSURE LEVEL dB(A)													
Nox as NO2 DISTANCE FROM THE ENGINE (M)	15M	95	84.7	90.7	90.2	90.8	89.8	87.8	86.5	84.1					
	7M	101	90.2	96.2	95.7	96.3	95.3	93.3	92	89.6					
	1M	112	101.2	107.2	106.7	107.3	106.3	104.3	103	100.6					
		Overall	63	125	250	500	1000	2000	4000	8000					
		Octave Band (Hz)													

FREE FIELD EXHAUST NOISE

		SOUND PRESSURE dB(A)													
DISTANCE FROM THE ENGINE (M)	15M	99	110.6	107.6	98.0	94.1	89.2	90.2	88.2	82.4					
	7M	106	117.4	114.9	106.2	100.9	96.9	96.9	95.0	90.2					
	1.5M	119	130.9	128.0	118.3	114.4	109.6	110.5	108.6	102.8					
		Overall	63	125	250	500	1000	2000	4000	8000					
		Octave Band (Hz)													

TOTAL DERATION FACTORS:

This table shows the deration required for various air inlet temperatures and altitudes. Use this information to help determine actual engine power for your site. The total deration factor includes deration due to altitude and ambient temperature, and air inlet manifold temperature deration.

AFTERCOOLER HEAT REJECTION FACTORS:

Aftercooler heat rejection is given for standard conditions of 25°C and 150 m altitude. To maintain a constant air inlet manifold temperature, as the air to turbo temperature goes up, so must the heat rejection. As altitude increases, the turbocharger must work harder to overcome the lower atmospheric pressure.

This increases the amount of heat that must be removed from the inlet air by the aftercooler. Use the aftercooler heat rejection factor to adjust for ambient and altitude conditions. Multiply this factor by the standard aftercooler heat rejection.

GENERATOR EFFICIENCY:

Generator power determined with an assumed generator efficiency of 96% [generator power = engine power x 0.96]. If the actual generator efficiency is less than 96% 8) FUEL CONSUMPTION DATA IS WITHOUT SEA WATER PUMP.

The factor is a percentage = 96% - actual generator efficiency

SOUND DATA:

Data determined by methods similar to ISO Standard DIS-8528-10. Accuracy Grade 3.
4/4/2010

1.0

DIMENSIONS

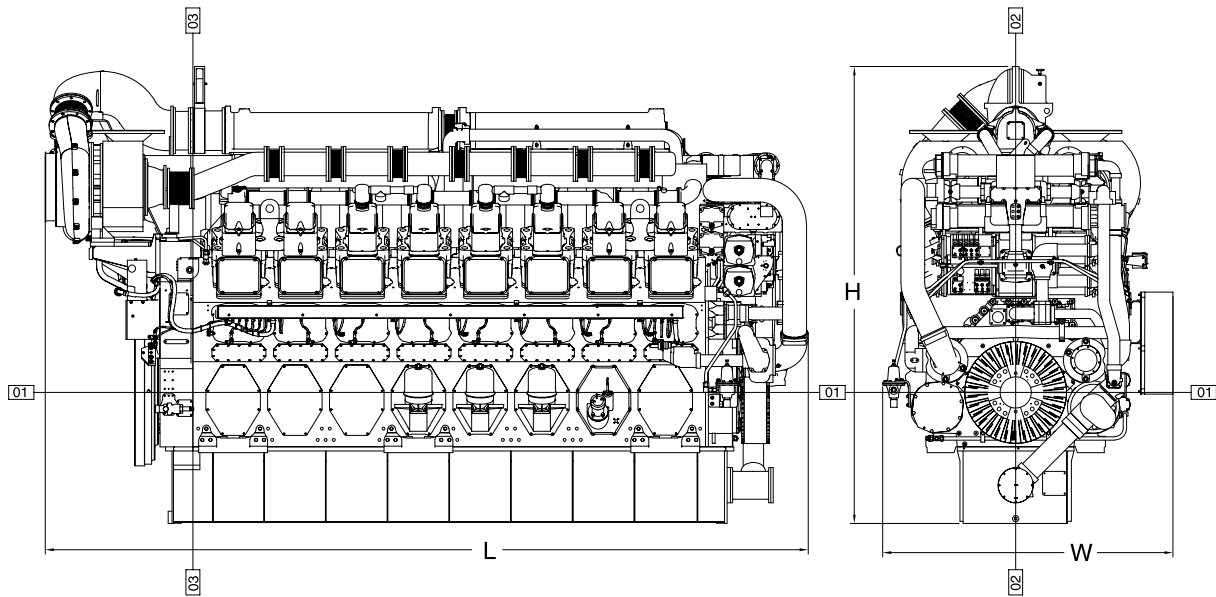

Engine Dimensions		
Length of Engine	5007 mm	197.0 in
Length with Generator	9314 mm	366.7 in
Width of Engine	1990 mm	78.3 in
Height	4167 mm	164.1 in
Engine Weight – dry (approx.)	28,500 kg	62,832 lb
Generator Weight – (approx.)	18,145 kg	40,000 lb

RATING DEFINITIONS AND CONDITIONS

Prime Power — 6,000 hrs./yr., for applications with load factors less than or equal to 60%. Rated load (100%) usage is limited to 1 hour in 12. 10% overload available.

Ratings are based on SAE J1995/ISO3046 standard conditions of 100 kPa (29.61 in. Hg), 25°C (77°F), and 30% relative humidity at the stated charge air cooler water temperature. Ratings also meet classification society maximum temperature requirements of 45°C (113°F) air temperature to the turbocharger and 32°C (90°F) seawater temperature without derate.

Additional ratings may be available for specific customer requirements. Consult your Cat representative for additional information.

Fuel rates are based on 35° API, 16°C (60°F) fuel used at 29°C (85°F) with a density of 838.9 g/liter (7.001 lbs/U.S. gal). Lower Heat Value (LHV) of 42 780 kJ/kg (18,390 Btu/lb). Tolerance is +5%. Includes all engine mounted pumps. BSFC without pumps is 3% less.

Marine Certification — Ratings are marine classification society approved by ABS, BV, CCS, DnV, GL, LRS, and RINA. These societies have also granted C280 factory line production approval which eliminates requirement for society surveyor witness test.

Performance data is calculated in accordance with tolerances and conditions stated in this specification sheet and is only intended for purposes of comparison with other manufacturers' engines. Actual engine performance may vary according to the particular application of the engine and operating conditions beyond Caterpillar's control.

Power produced at the flywheel will be within standard tolerances up to 49°C (120°F) combustion air temperature measured at the air cleaner inlet, and fuel temperature up to 52°C (125°F) measured at the fuel filter base. Power rated in accordance with NMMA procedure as crankshaft power. Reduce crankshaft power by 3% for propeller shaft power.

CAT, CATERPILLAR, their respective logos, ADEM, S•O•S, "Caterpillar Yellow" and the "Power Edge" trade dress, as well as corporate and product identity used herein, are trademarks of Caterpillar and may not be used without permission.