

C32 ACERT™

MARINE PROPULSION ENGINE

1622 mhp

(1600 bhp)

1193 kW



Image shown
may not reflect
actual engine

SPECIFICATIONS

Vee-12, 4-Stroke-Cycle-Diesel

- EPA Tier 3 Commercial/Recreational
- IMO II compliant
- 32.16 L displacement
- 2300 rpm rated engine speed
- 145 mm (5.71 in) bore x 162 mm (6.38 in) stroke
- Turbocharged and aftercooled aspiration
- Electronically governed
- Heat exchanger cooled
- Refill capacity
 - Cooling system: 79 L (20.9 gal)
 - Lube oil system: 85.2 L (22.5 gal)
- 24V electronic protection system
- SAE No. 0 flywheel and flywheel housing, 136 flywheel teeth
- Counterclockwise rotation from flywheel end
- 250-hour oil change interval
- Caterpillar Diesel Engine Oil 10W30 or 15W40



STANDARD ENGINE EQUIPMENT

- Air cleaner/fumes disposal system
- Electronic governor
- A4 Electronic Control Unit
- Electronic diagnostics and fault logging
- Engine and transmission monitoring
- Sea water aftercooler
- Titanium plate heat exchanger with expansion tank
- Gear-driven jacket water and sea water pumps
- Watercooled exhaust manifold and turbocharger
- MEUI fuel system
- Fuel priming and transfer pump
- Shallow sump oil pan
- Oil filter, dipstick, and oil filler (RH or LH service)
- Crankcase breather
- Adjustable front support

DIMENSIONS

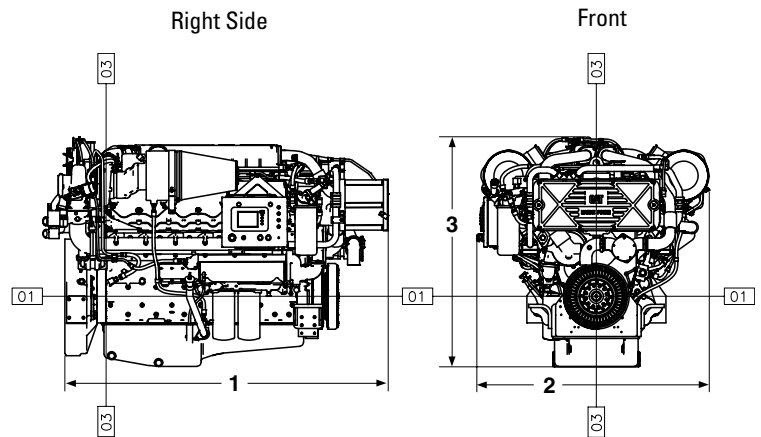

ENGINE DIMENSIONS & WEIGHT

(1) Length overall	2106.3 mm	82.9 in
(2) Width	1469.1 mm	57.8 in
(3) Height	1445.3 mm	56.9 in
Weight, Net Dry (approx)	3075 kg	6780 lb

Note: Do not use these dimensions for installation design. See general dimension drawings for detail.

MARINE ENGINE PERFORMANCE

Max Power 1622 mhp – D Rating (DM9449-00)				
rpm	bhp	g/hr	bkW	g/bkW-hr
2300	1599.8	86.6	1193	230.7
1900	1569.0	76.6	1170	207.9
1500	1330.3	62.3	992	199.5
1100	619.6	32.6	462	224.2
700	224.0	11.5	167	218.3

Prop Demand 1622 mhp – D Rating (DM9449-00)				
rpm	bhp	g/hr	bkW	g/bkW-hr
2300	1599.8	86.6	1193	230.7
1900	901.8	46.2	672.5	218.3
1500	443.7	23.0	330.9	220.2
1100	175.0	9.3	130.5	225.6
700	45.1	2.8	33.6	265.9

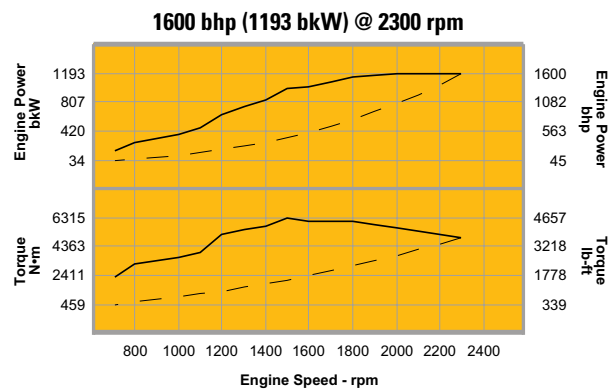

Maximum Power ————— Prop Demand - - - - -

RATING DEFINITIONS AND CONDITIONS

D Rating (Intermittent Duty)

Typical applications: For vessels operating at rated load and rated speed up to 16% of the time (up to 50% load factor). Typical applications could include but are not limited to vessels such as offshore

patrol boats, customs boats, police boats, some fishing boats, fireboats, or harbor tugs. Typical operation ranges from 1000 to 3000 hours per year.