

# C9.3 ACERT™

## MARINE GENERATOR SET PACKAGE

224 ekW      280 kVA      1800 rpm  
274 ekW      343 kVA      1800 rpm



Image shown may not reflect actual engine

### SPECIFICATIONS

#### I-6, 4-Stroke-Cycle-Diesel

- U.S. EPA Tier 3/IMO II certified/CCNR Stage II
- 9.3 liter (567.5 cu in) displacement
- 60 Hz 1800 rpm rated engine speed
- 115 mm (4.5 in) bore x 149 mm (5.8 in) stroke
- Turbocharged-aftercooled aspiration (ATAAC)
- Electronically governed
- Radiator cooled
- Refill capacity
  - Cooling system: 72 L (19 gal)
  - Lube oil system: 24.5 L (6.5 gal)
- Counterclockwise rotation from flywheel end
- 500-hour oil change interval



### STANDARD GENERATOR SET EQUIPMENT

- Common rail fuel system
- Plate-type oil cooler
- 3-phase generator with permanent magnet excitation system
- Belt-driven jacket-water pump
- Watercooled exhaust manifold and turbocharger
- Soft engine mount configuration below baseframe
- Available ratings to cover power demand of both 50 Hz and 60 Hz
- Sectional core radiator
- Radiator access panels
- Non-corrosive galvanized radiator
- Generator space heater
- Voltage regulator
- Current transformers
- Worldwide Extended Service Coverage (ESC) available

### DIMENSIONS

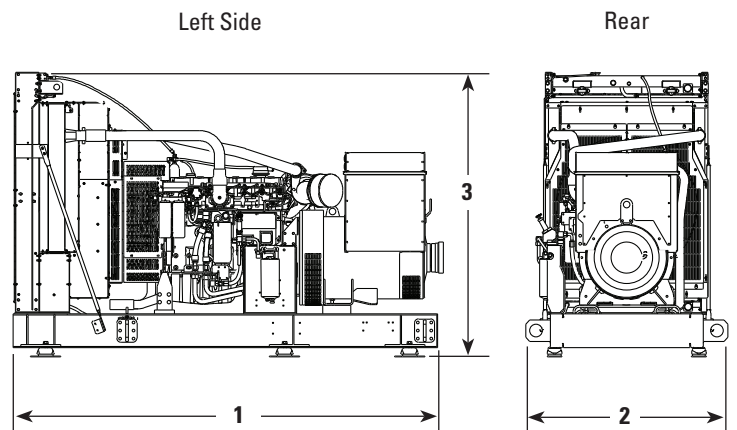

#### ENGINE DIMENSIONS & WEIGHT

<b>(1) Length</b>	3298 mm	129.8 in
<b>(2) Width</b>	1405 mm	55.3 in
<b>(3) Height</b>	2138 mm	84.2 in
<b>Weight, Net Dry (approx)</b>	3402 kg	7500 lb

Note: Do not use these dimensions for installation design. See general dimension drawings for detail.

## MARINE ENGINE PERFORMANCE

60 Hz

% Load	EM0785-00					EM0786-00				
	ekW	bhp	g/hr	bkW	g/bkW-hr	ekW	bhp	g/hr	bkW	g/bkW-hr
100	224	358	18.2	267	216.4	274	429	21.5	320	213.0
75	168	269	14.1	201	223.4	206	322	16.5	240	218.5
50	112	182	9.5	136	222.1	137	217	11.5	162	224.9
25	56	95	5.6	71	253.0	69	112	6.4	84	241.3
10	22	39	3.1	29	340.0	27	46	3.5	35	320.3

## OPTIONAL ATTACHMENTS

- Air System**  
 Air cleaner with integrated fumes disposal
- Control System**  
 Extension harnesses, MCS controller (MGCP III B, MGCP II), EMCP 4.2 control panel
- Generators & Generator Attachments**  
 RH or LH service, RTD module, potential transformer, power analyzer module, extension box, generator oversizing, IP44
- Fuel System**  
 Double wall fuel lines, manual or electric priming pump, simplex or duplex primary fuel filter, simplex or duplex secondary and tertiary fuel filter
- Lube System**  
 Simplex or duplex oil filter, manual sump pump and oil drain
- Starting System**  
 24V electric starting motor, air starting motor, jacket water heater, charging alternator
- Protection System**  
 SOLAS fuel and oil shielding; safety shutdowns for low oil pressure, high water temperature, and overspeed
- Marine Classification Society (MCS) Approval –**  
 ABS, BV, DNV, LR, GL, PRS, RINA, CCS, RS

## GENERATOR SPECIFICATIONS

Power Factor . . . . . 0.8  
 Frame . . . . . 44.2/46.2 LC6134B/D  
 Insulation . . . . . Class H  
 Temperature Rise . . . . . Class F  
 Winding Pitch Code . . . . . 2/3  
 Terminals . . . . . 12-lead 2 wires per lead  
 Drip Proof . . . . . IP 23

Air Flow (60 Hz) . . . . . 1.1 m<sup>3</sup>/s (2330 cfm)  
 Excitation System . . . . . Permanent Magnet  
 Voltage Regulation (steady state) . . . . . ±0.5%  
 Total Harmonic Content LL/LN . . . . . <4%  
 Wave Form: NEMA=TIF . . . . . <50  
 Wave Form: I.E.C.=THF . . . . . <2%

CAT, CATERPILLAR, their respective logos, ACERT, "Caterpillar Yellow", the "Power Edge" trade dress as well as corporate and product identity used herein, are trademarks of Caterpillar and may not be used without permission.