



Cat[®] MCU2

MAIN CONTROL UNIT

APPLICATIONS:

- Visualization of all longwall data underground at gate end
- Change and control parameter from gate end
- Analysis of longwall system operation and situation
- Provide relevant process and HEALTH data to surface mine control room

FEATURES:

- Comprehensive software suite (HEALTH for Longwall) serving application software for Roof Support, AFC, Shearer and Plow
- Multi-language support (English, German, Russian, Polish, Czech, Spanish, Chinese)
- Robust IPC architecture for reliable operation in hazardous areas
- IS external keyboard with mouse function
- Robust design for sudden Methane face wide power off

Specifications

Electrical Power Supply

- Power supply of the explosion-proof part, 110-240V AC
- Power supply of the intrinsically safe part, 12V DC, maximum 2A
- Non-intrinsically safe USB interface

Components

Processor	Intel Core i7, 2.1 GHz	
RAM Memory	4 GB	
Data Memory	2 × 120 GB SSD	
Hard Drive – 1 TB	6.4 cm	2.5 in
Display	48.3 cm	19 in
Resolution	1280:1024	
Operating System	Windows 7	
Input Equipment	Keyboard with integrated mouse	

Intrinsically Safe Interfaces

- COM 1 BIDI SKK24
- COM 2 BIDI SKK24
- COM 3 BIDI SKK24
- COM 4 BIDI SKK24
- Ethernet via Fiber-Optic Cable – 9 μm

Certifications and Identification

Certification	ATEX (within system: MA and GOST)	
Type of Protection	I M2 EEx ib I	
Temperature Range	-20° C to +60° C	-4° F to +140° F

Weight

Approximate Weight	200 kg	441 lb
--------------------	--------	--------

MCU2 Main Control Unit

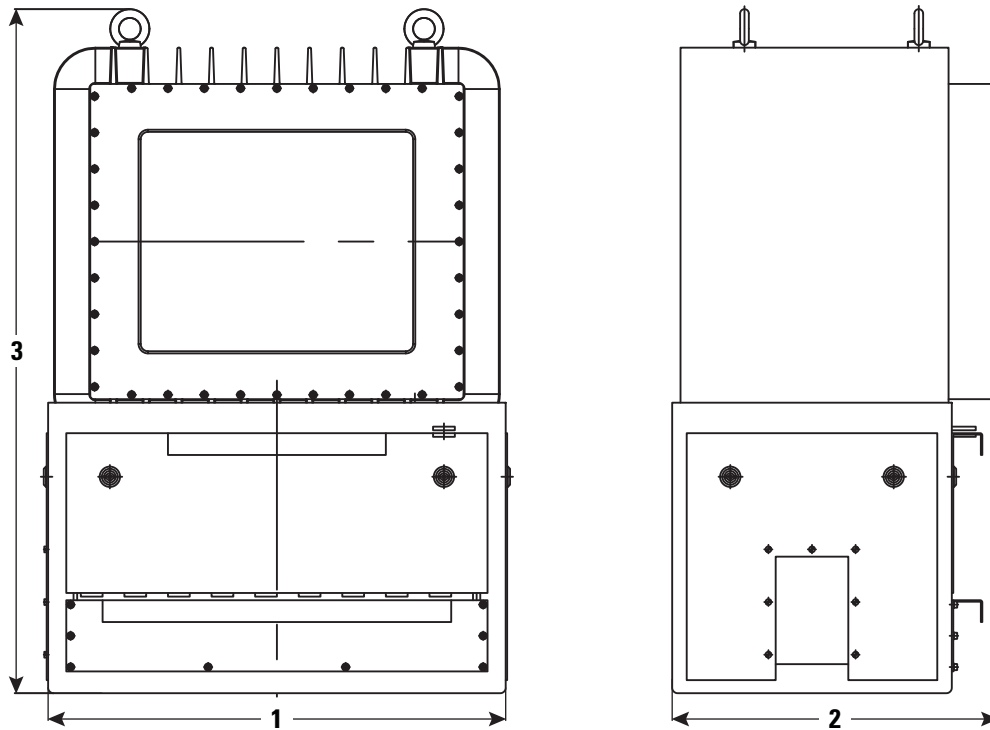

Dimensions (All dimensions are approximate.)

1	Width	630 mm	24.80 in
2	Height	450 mm	17.72 in
3	Length		
	Small Base	945 mm	37.20 in
	Large Base	1145 mm	45.08 in

For more complete information on Cat® products, dealer services, and industry solutions, visit us on the web at www.cat.com

© 2014 Caterpillar
All Rights Reserved
Printed in U.S.A.

Materials and specifications are subject to change without notice. Featured machines in photos may include additional equipment. See your Cat dealer for available options.

CAT, CATERPILLAR, SAFETY.CAT.COM, their respective logos, "Caterpillar Yellow" and the "Power Edge" trade dress, as well as corporate and product identity used herein, are trademarks of Caterpillar and may not be used without permission.

AEHQ7146-01 (03-14)
Replaces AEHQ7146

