



Cat[®] SH650

ROOF SUPPORT CARRIER

Specifications

Weights

Roof Support Carrier Empty Weights		
Less Battery	31.7 kg	70,000 lb
With 64-125-33, 200 amp Hour Battery	46 kg	101,500 lb

Speed

Tram Speed (Calculated based on 4% rolling resistance)		
Level and Empty on 0% Grade	5.1 km/h	3.2 mph
Level and Loaded on 0% Grade	3.8 km/h	2.4 mph

Lift and Carry Capacity

Without Ballast	45.4 tonne at 1.57 m	50 ton at 62 in
-----------------	-------------------------	--------------------

- Capacities based on 54 × 26 solid tire

Drive Train

Tram Motor	Two mine traction, direct current, dual field, laminated frame gear motors rated at 37.3 kW (50 hp) each for one hour (total of 74.6 kW [100 hp] per machine) at 1,500 rpm and 110V DC; foot mounted. Each 37.3 kW (50 hp) tram motor is coupled with a 5.77:1 ratio gearbox.
Drive Lines	8.5 C Series shafts with 76.2 mm (3 in) slip joints
Axles	Front/rear rigid mounted outboard planetary axles with wet disc spring applied, hydraulically released brakes.
Motor Overspeed Protection	Motor system is designed to prevent tram motor from overspeeding.

Brakes

Service and Emergency/Park	Spring applied hydraulic release SAHR 4-wheel wet disc Left pedal activated Controlled by reverse modulating valve
----------------------------	---

Hydraulics

Pump Motor	Mine duty, laminated frame, direct current motor rated at 11.93 kW (16 hp) for one hour; 110V DC; MSHA totally enclosed explosion proof; non-ventilated cooling.
Pump	The pump is a splined shaft fit to the pump motor.
Filtration	Standard – Three pressure filters, 10 micron filter on the main hydraulic circuit, 10 micron filter on the accumulator circuit, 10 micron on the pilot valve circuit. One tank mounted 25 micron return filter, and 10 micron fluid port filters on key control circuits.
Reservoir	A 184.2 L (50 gal) capacity, integral reservoir.
Reservoir Fill System	Venturi Jet refill system located on opposite side from operator on the middle frame that allows refilling of reservoir through the return line oil filter.
Valve Bank	Seven section, pilot operated, parallel type with internal relief and a dash mounted, glycerin filled pressure gauge.
Hydraulic PTO	Two (2) quick coupler connections, 175.8 bar (2,550 psi) maximum recommended operating pressure.
Tilt Lift Cylinder	Two (2) 241 mm (9½ in) bore, double acting cylinders with load locking valves.
Bell-Crank Lift Cylinder	Two (2) 203 mm (8 in) bore, double acting cylinders with load locking valves.
Steering Cylinder	Two (2) 127 mm (5 in) bore, double acting cylinders with dual relief setting at 159 bar (2,300 psi).
Battery Changer Cylinder	Two (2) 152 mm (6 in) bore, double acting cylinders with load locking valves.

SH650 Roof Support Carrier

Standard Load Lift

A combination bell crank arm and bell crank lifting cylinder, for vertical lifting and tilting cylinders for tilt lifting of a universal load lift frame that is provided as standard equipment. Heavy duty, pin on, forged alloy steel forks 152 mm × 356 mm × 2134 mm (6 in × 14 in × 84 in), are standard for 45.4 tonne (50 ton) lift capability.

Winch	A fully hydraulic operated, 31 751 kg (70,000 lb) winch, with two speed pay in/out. Heavy duty fabricated steel drum.
Winch Cable Assembly (Options)	The standard winch cable is 22.2 mm (7/8 in) diameter, 6 × 36, IWRC, EIPS, class bright cable equipped with a swaged-on thimble, connecting link and swivel hook. Coated 22.2 mm (7/8 in) diameter, 6 × 36, IWRC, TK/FFV cable equipped with a swaged-on thimble, connecting link and swivel hook and a swaged stud quick attachment. A 22.2 mm (7/8 in) diameter, twelve strand braided synthetic rope with swivel hook.
Tri-Section Frame	The tri-section frame design featuring multiple plate, modular construction for maximum strength and structural integrity and the design produces a maximum of stability while maneuvering with a heavy load. All high stressed areas are manufactured with T1 steel.
Center Section	Center section is designed with hardened 114.3 mm (4.5 in) diameter pivot pins and spherical bearings to provide maximum load transfer and long component life. Entire center section area manufactured with T1 steel.
Oscillation Section	An 813 mm (32 in) diameter bearing with 44.5 mm (1 3/4 in) diameter rolling elements provides 20 degrees of oscillation.
Battery Change System	Hydraulically operated, bell crank, forklift battery charger to pick up battery from grade. The battery/battery tray assembly can be further raised to increase the rear approach clearance up to 508 mm (20 in).

Operator's Compartment

1. Side Egress Access
2. Left Hand Steering with Control Stick with the following functions:
 - Pump motor start/stop
 - Park brake release/set
 - Directional headlights
 - Tram direction
 - Stop
3. Panic Strip Switch that de-energizes the Electrical system and applies the automatic brake
4. Dash Mounted Glycerin Filled Hydraulic Gauges for accumulator, system pressure and emergency brake
5. Warning Horn
6. Right Hand Tilt-Lift Control Lever
7. LH Hydraulic Winch (In-Out) Control Lever
8. LH Hydraulic PTO Control Lever
9. LH Battery Changer Control Lever
10. Circuit Breaker Reset
11. Emergency/Park Brake Release
12. Right Foot Accelerator Pedal

13. Left Foot Brake Pedal Manuals:
 - Two Parts Manuals
 - Two Operation and Preventive Maintenance Manuals
 - Two Electrical Troubleshooting Guides
 - Two Battery Maintenance Manuals
 - Two Battery Maintenance Charts
 - One LinkOne CD which includes all above manuals in electronic format

Hydraulic Installation (Standard)

JIC fittings with 345 bar (5,000 psi) hosing; MSHA 2G flame resistant approved.

Electrical Controller (Options)

- Cat 2000-2400 amp (Two [2] 1200 amp IGBT panels, one per tram motor), 110V DC, IGBT, variable-stepless speed control. Electrical controller has no directional contactors, commutation coil or capacitor bank. Controlled by a microprocessor logic card. System is equipped with a dashboard display unit, in an explosion proof enclosure, for troubleshooting and system monitoring.
- RTD monitoring of each tram motor and pump motor in addition to the Cat 2000-2400 amp (Two [2] 1200 amp IGBT panels, one per tram motor), 110V DC, IGBT, variable-stepless speed control. Electrical controller has no directional contactors, commutation coil or capacitor bank. Controlled by a microprocessor logic card. System is equipped with a dashboard display unit, in an explosion proof enclosure, for troubleshooting and system monitoring. Available with 11.93 kW (16 hp) pump motor.

Circuit Breaker Options

- Magnetic, UVR Trip – controller enclosure equipped with UVR trip circuit breaker rated mine duty 800 amp frame, 600 volt.
- Standard Cab mounted hydraulic breaker reset with single push breaker trip function. System equipped with a hand pump and reservoir for resetting the tripped breaker.
- Optional Cab mounted breaker reset using a single high capacity, swivel end style push/pull cable.

Cab Options

- Manual Adjustable Cab Assembly – MSHA certified cab, formed support plate, access handles, completely enclosed grid and dual corner opening doors.
- Hydraulically Adjustable Cab Assembly – MSHA certified cab, formed support plate, access handles, completely enclosed grid and dual corner opening doors.

Tire/Wheel Options

- 54×26 SETCO Solid Tires
- 54×26 SETCO Solid Tires with Heavy Side Wall Plate Protection
- 48×25 SETCO Solid Tires

Lift Attachments

- Fork Assembly, 2134 mm (84 ft) Overall Length – set of 2134 mm (84 ft) overall length up-set forged forks designed to lift and carry 45.4 tonne (50 ton) at 1575 mm (62 in) from the load lift plate mounted to the machine.
- Quick Attach Lift Plate, 2134 mm (84 in) (Fork Assembly Required) – designed to lift and carry 45.4 tonne (50 ton) at 1575 mm (62 in) from the face of the load lift frame. The plate mounts directly to the 2134 mm (84 in) forks through two parallel pockets and is held in place with two drop pins chained to the lift plate.

Lighting System Options

MCI, Halogen, 12V DC, 50 watt – two 12 volt quartz halogen front headlights with protective guard, and two rear headlights with protective guard that move up and down with the battery lift system.
OCENCO, Halogen, 12V DC, 50 watt – two 12 volt quartz halogen.

Fire Suppression

Automatic/Manual with NPT Fittings, Eight Point, two on the front frame and six on the rear. 9.1 kg (20 lb) hand held unit class 10A60BC

Machine Accessories (Optional)

1. Cable Guide Assembly.
2. Reflector Installation – additional reflectors mounted in strategic locations on the machine.
3. Cat 2000 Hand Held Calibrator – hand held LED calibrator, for use in adjusting and troubleshooting procedures on the Cat 2000 electrical controller.
4. Pressure Switch Kit, Intrinsically Safe – electric/hydraulic system to shutdown the tram motors in the event of low hydraulic system pressure.
5. Shroeder Testmate with JIC fittings.
6. Power Disconnect Switch (required in PA).
7. Tow Hook Installation – two tow hooks mounted on the front of machine rated at 10.8 tonne (12 ton) each.
8. Tram and Pump motors with RTD monitoring.
9. Mine Duty, laminated frame, direct current motor rated at 16.4 kW (22 hp) for one hour; 110V DC; MSHA totally enclosed explosion proof; non-ventilated cooling; and foot mounted.
10. Optional Fork Plates or customer specified designs.
11. Battery Tray (One Required for Each Battery Assembly) – heavy duty welded steel battery trays for use with 2000 amp hour battery assemblies.
12. Park Brake/Tram Inhibit installation kit providing brake system pressure monitoring to limit the potential to tram through parking brakes.
13. In line Flow meter monitoring of the tandem hydraulic pump outputs. Provides the addition of two analog gauges in the hydraulic bay.
14. Tilt Cylinder protection kit consisting of two, hinged, heavy duty steel plates protecting the Tilt Cylinder Rods.
15. Shield Deflector/cage protector consisting of a frame mounted supported structure, 25.4 mm (1 in) higher than the Canopy at maximum height.
16. Ultra heavy duty fork mounted bucket with ejector with quick attach pins.

Machine Battery

Battery Tray – dual tray battery assembly
Optional 64SS125-33; 2000 amp hour battery
Battery with Plastisol
Coated Tray
Battery Receptacle Kit
Battery Filling System

Battery Charger Options

Single Output for One Battery
Dual Output for Two Batteries

SH650 Roof Support Carrier

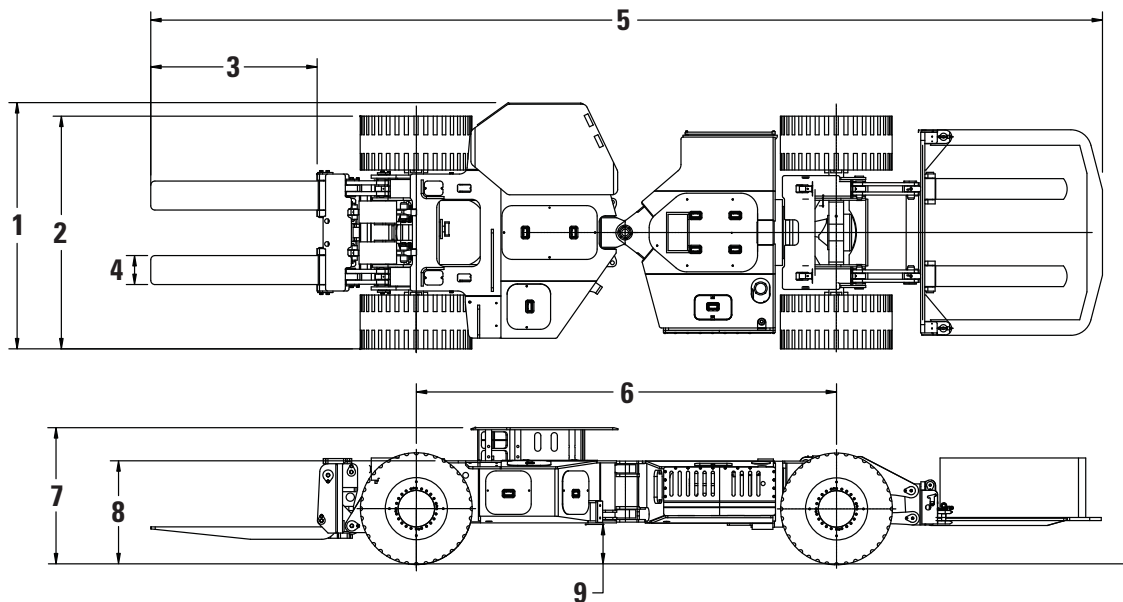

Dimensions (All dimensions are approximate.)

1 Overall Width		
With Attachments and 1219 mm (48 in) Tires	2819 mm	9 ft 3 in
With Attachments and 1371 mm (54 in) Tires	3021 mm	9 ft 11 in
2 Width	2855 mm	9 ft 4 in
3 Length of Fork	2042 mm	6 ft 8 in
4 Width of Fork	356 mm	1 ft 2 in
5 Length		
Less Load Lifting and Battery Lift Forks	7468 mm	24 ft 6 in
With 2134 mm (84 in) Lifting Fork	11 679 mm	38 ft 4 in
With Lift Plate Attachment	12 039 mm	39 ft 6 in
6 Wheelbase	5156 mm	16 ft 11 in
7 Cab Height (Lower cab heights available on request)	1778 mm	5 ft 10 in
With 1219 mm (48 in) Tires	Standard Cabs adjust from 1448 mm to 1702 mm	Standard Cabs adjust from 57 in to 67 in
With 1371 mm (54 in) Tires	Standard Cabs adjust from 1524 mm to 1778 mm	Standard Cabs adjust from 60 in to 70 in
8 Chassis Height (Nominal)		
With 1219 mm (48 in) Tires	1168 mm	46 in
With 1371 mm (54 in) Tires	1263 mm	49 in
9 Ground Clearance (Nominal) –		
Please reference sales drawing for Ground Clearance profile		
With 1219 mm (48 in) Tires	406 mm	16 in
With 1371 mm (54 in) Tires	471 mm	19 in
Inside Turn Radius	4140 mm	13 ft 7 in
Outside Turn Radius	7214 mm	23 ft 8 in
Steering Articulation – Total	100°	100°
Frame Oscillation – Total	40°	40°

Detailed GA drawings available for specific dimensions and component locations.

Shown with 1371 mm (54 in) tires.

For more complete information on Cat products, dealer services, and industry solutions, visit us on the web at www.cat.com

AEHQ6840 (05-13)

© 2013 Caterpillar Inc.
All Rights Reserved
Printed in U.S.A.

Materials and specifications are subject to change without notice. Featured machines in photos may include additional equipment. See your Cat dealer for available options.

CAT, CATERPILLAR, SAFETY.CAT.COM, their respective logos, "Caterpillar Yellow" and the "Power Edge" trade dress, as well as corporate and product identity used herein, are trademarks of Caterpillar and may not be used without permission.

