



Cat[®] Landscape Tillers

Skid Steer Loaders
Multi Terrain Loaders
Compact Track Loaders
Compact Wheel Loaders

Cat[®] Landscape Tillers are designed for breaking up and pulverizing soil, mixing compost or other materials into existing soil, and stabilizing and leveling existing terrain in landscape finish applications. They are ideal for residential, commercial, agricultural, building construction, lawn care and golf course maintenance applications.

Features:

Single motor direct drive system

- Single motor direct drive system is matched to the machine's auxiliary hydraulic system for maximum performance and versatility.

Tungsten carbide double-edge bolt-on tines

- Tungsten carbide double-edge bolt-on tines are hardened for maximum strength, durability and wear life in the toughest soil conditions. The bolt-on design provides quick change versatility and extended work tool life.

Unique spiral tine arrangement

- A unique spiral tine arrangement provides 10% greater cutting performance over tillers with standard placements.

Two full-width torque tubes

- Two full-width torque tubes provide rigid structural enforcement of tiller housing. Front torque tube design minimizes hood damage caused from larger rocks.

Arm level indicator

- Arm level indicator provides operator a visual set-up and operating reference with top tiller attachment arms designed parallel to skid shoe.

Adjustable skid shoes

- Adjustable skid shoes with three position tiller depth adjustment allows for tilling depth to be quickly adjusted without skid shoe removal.

Compact work tool envelope

- A compact work tool envelope allows for tilling next to sidewalks and structures.

Cat XT[™]-3 ES hose, couplings and O-ring face seals

- Cat XT-3 ES hose, couplings and O-ring face seals provide superior, leak-free performance and reliability. All hoses are wrapped with nylon woven cordura sleeving for added operator protection. Hydraulic quick disconnects enable fast tool changes.

Quick coupler

- Rugged, opposing edge design holds the work tool securely and allows the operator to quickly change from one high performance Cat Work Tool to another.

Compatibility

Model Machines

LT13B 226B3, 247B3, 236D, 242D, 246D, 257D, 259D, 262D, 272D, 272D XHP, 277D, 279D, 287D, 289D, 299D, 299D XHP, 906H2, 907H2, 908H2

LT18B 247B3, 236D, 246D, 257D, 259D, 262D, 272D, 272D XHP, 277D, 279D, 287D, 289D, 299D, 299D XHP, 906H2, 907H2, 908H2



Cat Landscape Tillers

Specifications

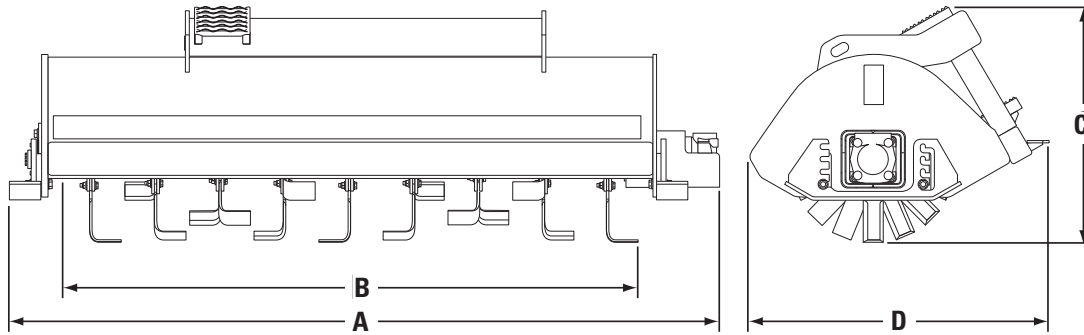

			LT13B		LT18B	
A Overall width	mm	(in)	1788	(70.5)	2271	(89.5)
B Overall working width	mm	(in)	1321	(52)	1847	(73)
C Overall height	mm	(in)	755	(30)	755	(30)
D Overall length	mm	(in)	956	(38)	956	(38)
Working depth range	mm	(in)	25-152	(1-6)	25-152	(1-6)
Unit weight	kg	(lb)	340	(750)	420	(926)
Required hydraulic flow range	L/min	(gpm)	42-86	(11-23)	60-114	(16-30)
Optimal hydraulic pressure range	bar	(psi)	145-235	(2,100-3,400)	207-310	(3,000-4,500)
Drum speed @ max flow			127 rpm @ 80 L/min (21 gpm)		127 rpm @ 80 L/min (21 gpm)	
Motor displacement	cm ³ /rev	(in ³ /rev)	629.1	(38.4)	629.1	(38.4)
Number of hard-faced tines			24		36	

Theoretical values calculated at 100% efficiency.

For more complete information on Cat products, dealer services, and industry solutions, visit us on the web at www.cat.com

© 2013 Caterpillar Inc.
All Rights Reserved
Printed in U.S.A.

Materials and specifications are subject to change without notice. Featured machines in photos may include additional equipment. See your Cat dealer for available options.

CAT, CATERPILLAR, SAFETY.CAT.COM, their respective logos, "Caterpillar Yellow" and the "Power Edge" trade dress, as well as corporate and product identity used herein, are trademarks of Caterpillar and may not be used without permission.

AEHQ5831-02 (10-13)
Replaces AEHQ5831-01

