

Cat[®]

B Series Cold Planers

SKID STEER LOADERS
MULTI TERRAIN LOADERS
COMPACT TRACK LOADERS
COMPACT WHEEL LOADERS

Cat[®] Cold Planers are designed for small paving jobs in residential and commercial applications, and are primarily used to economically restore asphalt and concrete surfaces. They are ideal for milling imperfections prior to resurfacing, removing deteriorated pavement, removing traffic lane stripes and jobs where the use of dedicated planers is limited.

Features:

Self-leveling design

- Self-leveling design automatically levels itself when placed on the ground for consistent depth control without operator adjustments and excellent spoil retention.

Two wear resistant skid plates

- Two wear resistant skid plates remain parallel to the ground for optimum stability.

Hydraulic side-shift

- Hydraulic side-shift permits close planing to curbs, walls and other obstructions.

Independent left/right depth control

- Independent left/right depth control allows maximum drum depths to be adjusted independently on each skid. The gauges are easily viewable from the cab. Independent depth control is mechanical on standard flow planers and hydraulic on high flow planers.

Max Pro Pressure Gauge

- Max Pro Pressure Gauge provides operator feedback to adjust speed for maximum productivity in changing material loads. Gauge displays planer performance in real-time conditions and is visible from the cab. Standard on XHP models.

Float, spring tilt and hydraulic tilt

- Float enables planers to follow the contour of the surface. Float is activated by a knob and is only available on high flow and XHP planers. Spring tilt and hydraulic tilt enable planers to oscillate for angled cuts. Tilt is hydraulically controlled on high flow models and spring controlled on standard flow planers.

Direct drive system

- Direct drive system on the standard flow models features a variable speed, uni-directional, gerotor style hydraulic motor. Direct drive system on high flow and XHP models features a hydraulic radial piston motor to ensure maximum cutting rate and drum torque for optimal production performance and efficiency.

Optional concrete bits, extreme life bits and water sprinkler kits

- Optional concrete bits, extreme life bits and water sprinkler kits are available for all models.

Cat XT[™] and medium pressure hose, couplings and O-ring face seals

- Cat XT and medium pressure hose, couplings and O-ring face seals provide superior, leak-free performance and reliability. All hoses are wrapped with nylon woven cordura sleeving for added operator protection. Hydraulic quick disconnects enable fast tool changes.

Quick coupler

- Rugged, opposing edge design holds the work tool securely and allows the operator to quickly change from one high performance Cat Work Tool to another.

Compatibility

Model	Machines
PC104B	226B3, 247B3, 236D, 242D, 246D, 257D, 259D, 262D, 272D, 272D XHP, 277D, 279D, 287D, 289D, 299D, 299D XHP, 906H2, 907H2, 908H2
PC205B*	226B3, 236D, 242D, 246D, 257D, 259D, 262D, 272D, 272D XHP, 277D, 279D, 287D, 289D, 299D, 299D XHP, 906H2, 907H2, 908H2
PC305B#	226B3, 242D, 246D, 257D, 259D, 262D, 272D, 272D XHP, 277D, 279D, 287D, 289D, 299D, 299D XHP, 906H2, 907H2, 908H2
PC306B#	226B3, 242D, 246D, 257D, 259D, 262D, 272D, 272D XHP, 277D, 279D, 287D, 289D, 299D, 299D XHP, 906H2, 907H2, 908H2
PC310B#	246D, 257D, 259D, 262D, 272D, 272D XHP, 277D, 279D, 287D, 289D, 299D, 299D XHP, 906H2, 907H2, 908H2
PC408B	272D XHP, 299D XHP
PC412B	272D XHP, 299D XHP

* Requires high flow option on machine. Operates in standard flow on high flow XPS or XHP option machines.

Requires high flow XPS option on machine. Operates in high flow XPS on XHP machines.



Cat B Series Cold Planers

Specifications

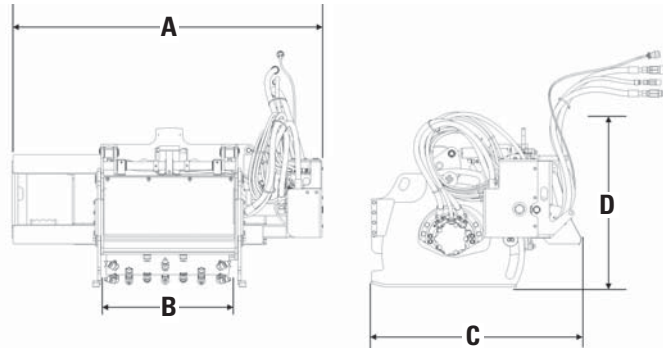

			PC104B	PC205B	PC305B	PC306B	PC310B	PC408B	PC412B
A Overall width	mm (in)		1730 (68)	1730 (68)	1858 (73)	1858 (73)	1858 (73)	1858 (73)	1858 (73)
B Maximum drum width	mm (in)		350 (14)	450 (18)	450 (18)	600 (24)	1000 (39)	750 (30)	1200 (47)
C Length	mm (in)		1120 (44)	1184 (47)	1240 (49)	1240 (49)	1140 (45)	1270 (50)	1140 (45)
D Overall height	mm (in)		950 (37)	1080 (43)	1100 (43)	1100 (43)	965 (38)	1100 (43)	965 (38)
Weight	kg (lb)		670 (1,474)	730 (1,606)	860 (1,896)	935 (2,061)	1050 (2,310)	1050 (2,315)	1170 (2,580)
Optimum hydraulic flow	L/min (gpm)		60-80 (16-21)	80-115 (21-31)	100-125 (26-33)	100-125 (26-33)	125 (33)	150 (40)	150 (40)
Optimum hydraulic pressure	bar (psi)		230 (3,330)	230 (3,330)	230-280 (3,330-4,000)	230-280 (3,330-4,000)	280 (4,000)	280 (4,000)	280 (4,000)
Drum torque/max. pressure	N·m (lb-ft)		1350 (996)	2047 (1,510)	3470 (2,558)	3470 (2,558)	3350 (2,470)	3724 (2,746)	4108 (3,030)
Drum speed @ max. flow	rpm		150-200	142-205	160	160	166	143	161
Conical bits			42/350 mm (13.8 in) drum	48/450 mm (18 in) drum	48/450 mm (18 in) drum	60/600 mm (24 in) drum	78/1000 mm (40 in) drum	60/750 mm (30 in) drum	90/1200 mm (47 in) drum
Standard bit type			All purpose	All purpose	All purpose	All purpose	All purpose	All purpose	All purpose
Maximum depth of cut	mm (in)		150 (6)	150 (6)	170 (6.7)	170 (7)	130 (5)	170 (7)	130 (5)
Optional drum widths/depts	mm (in)		400/150 (16/6)	80/200 (3/8) 152/200 (6/8) 203/200 (8/8) 305/200 (12/8) 350/200 (14/8) 400/200 (16/8) 450/150 (18/6)	80/200 (3/8) 152/200 (6/8) 203/200 (8/8) 305/200 (12/8) 350/200 (14/8)	80/200 (3/8) 152/200 (6/8) 203/200 (8/8) 305/200 (12/8) 350/200 (14/8) 400/200 (16/8) 450/150 (18/6) 600/180 (24/7)	— —	80/200 (3/8) 152/200 (6/8) 203/200 (8/8) 305/200 (12/8) 350/200 (14/8) 400/200 (16/8) 450/200 (18/8) 610/178 (24/7)	— —
Tilt angle range			±8.5°	±8.5°	±8°	±8°	±6.5°	±6.5°	±6.5°
Side-shift travel	mm (in)		650 (26)	650 (26)	750 (30)	750 (30)	650 (26)	650 (26)	550 (22)

For more complete information on Cat products, dealer services, and industry solutions, visit us on the web at www.cat.com

© 2014 Caterpillar
All Rights Reserved
Printed in U.S.A.

AEHQ6789-02 (06-14)
Replaces AEHQ6789-01

Materials and specifications are subject to change without notice. Featured machines in photos may include additional equipment. See your Cat dealer for available options.

CAT, CATERPILLAR, SAFETY.CAT.COM, their respective logos, "Caterpillar Yellow" and the "Power Edge" trade dress, as well as corporate and product identity used herein, are trademarks of Caterpillar and may not be used without permission.

