

# S305, S320B, S325B, S340B, S365C, S385C

## Mobile Scrap and Demolition Shears for Hydraulic Excavators



### Features

#### Enhanced Performance

Cat shears are designed to cut and reduce the size of metal items commonly found in scrap yards and demolition sites. The unique straight lower jaw design effectively enhances the cutting force by facilitating the spreading out of steel along the length of the jaw, creating a more efficient cut. The tip penetrates material and maximizes productivity when piercing is required.

#### Bolt-on Piercing Tip

C-series shears incorporate a bolt-on piercing tip — a key feature for enhancing up-time. Dual sided, fully reversible and identical piercing blades (S365C and S385C).

#### Improved Durability

The new shape of the housing provides improved protection for shear components and better positions the jaw relative to the stick. The cutting edge design greatly improves the protection of the cylinder, which eliminates the use of a cylinder guard by extending the housing to cover the cylinder rod. A newly designed hub is better protected against damage.

#### Optimized Serviceability

Large access panels on the top, bottom and sides of the shear housing make it easier to service inside components. The unique hub adjustment quickly compensates blade wear.

#### Enhances Safety

Safety during maintenance work is enhanced with an improved jaw and rotation service locks. A standard flagged pin is used to secure the cylinder rod to the moving jaw.



## Easy to Maintain

### Bolt-on Tip

The Cat Bolt-On Piercing Tip greatly enhances the maintainability of Cat Shears. The bolt-on tip can be replaced in a very short time using common hand tools.

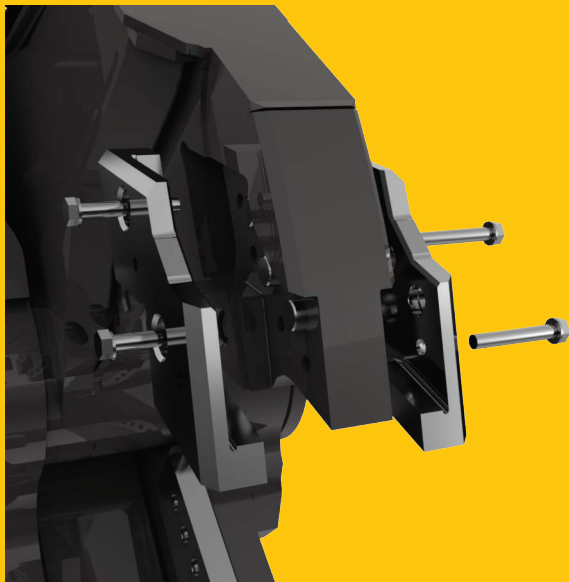

# Bolt-on Piercing Tip: S365C and S385C

C series shears incorporate a bolt-on piercing tip, a key feature for enhancing up-time for shears. Changeable with common hand tools, the tip has several key features:

## Dual sided

The Cat tip assembly protects the moving jaw on both sides. There is sufficient length to protect the parent material as the moving jaw enters into the fixed jaw.

## Fully reversible

The bolt-on tip is comprised of two identical, symmetrical piercing blades; each of which has two functional edges. If the tip wears or breaks, the piercing blades can be quickly reversed, putting the shear quickly back in production.

## Identical Piercing Blades

As mentioned above, the Cat bolt-on piercing tip uses a single part for both sides of the jaw, and identical mounting hardware. Managing spare parts is more economical, maintenance process is simpler resulting in lowering owning and operating costs.



## Durable, Reversible Blades

Blades are very durable with long wear – 150 to 250 hours per blade edge (depending on application). Blades are fully reversible and can be flipped and rotated to utilize four cutting edges on each section.

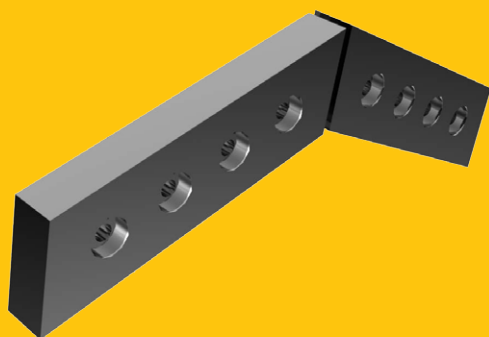

## Quick Blade Change

Blades in both jaws are held in place with threaded bolt holes and slotted shims making change-out quick and easy. Bushings prevent bolts from loosening and breaking. Shims maintain the gap between the blades for effective cutting.

# Features of Cat Shears

## 1 Bolt-On Piercing Tip –

This innovative design brings Cat shears the flexibility of a bolt-on tip with features like total reverse-ability and dual-sided protection.

## 2 Straight Lower Jaw, Apex Upper Jaw –

Design improves material cutting capability.

## 3 Wear Plates –

The front of the fixed jaw is protected by weld-on wear plates, protecting the parent metal when the shear is working in scrap piles.

## 4 Jaw Lock & Rotation lock –

Safety during maintenance work and transport is enhanced with an improved jaw and rotation service locks.

## 5 Protective Housing –

The shape of the housing protects the cylinder rod through the entire cutting cycle without the need for additional guarding.

## 6 Adjustable Hub –

An unique feature of Cat Shears is the adjustable hub. It allows easy and fast jaw realignment as required, and is field serviceable.

## 7 Slewing Ring Rotation –

Cat shears feature a 360 degree, bi-directional rotation system. The shear can be quickly positioned for optimum cutting, improving productivity in both scrap and demolition applications. The heavy-duty rotator is built to withstand the forces generated by the excavator and shear.

## 8 Speed Valve –

The hydraulic cylinder is regenerated via a speed valve improves cycle time performance.

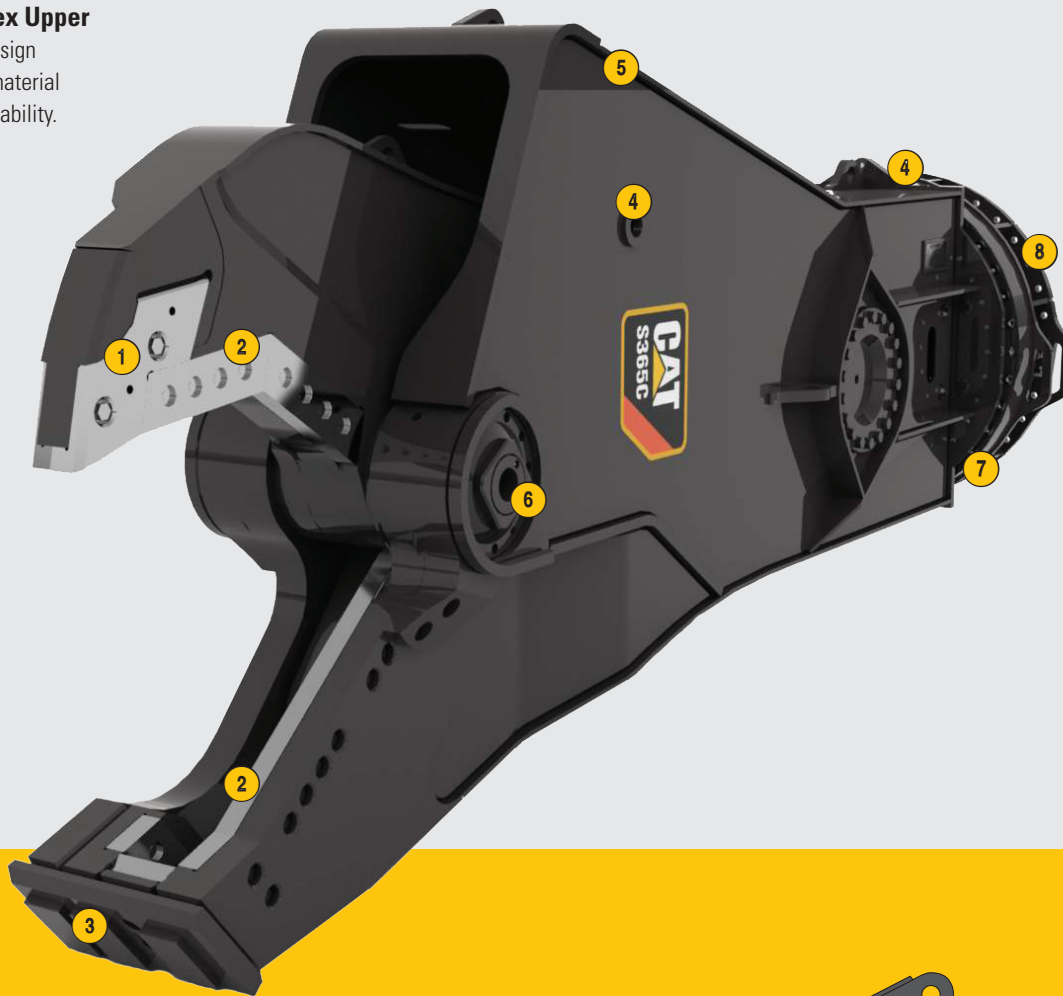

## 9 Panels for Easy Access –

Large access panels provide a way to reach the shear internals from the front, back or either side.

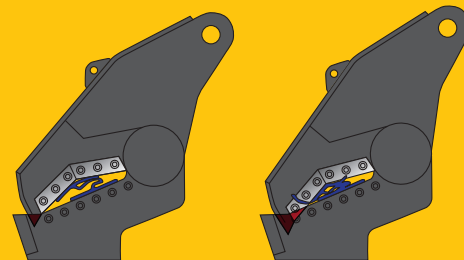

**Straight lower jaw enhances performance –** Maximizes shear force, creates a more efficient cut.

# B series Shears: S320B, S325B and S340B

Cat S320B, S325B and S340B Shears share almost all the same benefits as the C series. There are a couple of key differences.

B series shears utilize a weld-on piercing tip. This tip is made of hardened steel and features excellent wear characteristics. It can be repeatedly hardfaced for long life and effective piercing at a low operating cost.

Drop side of the jaw is protected by a bolt-on replaceable wear plate. This protects the jaw as it passes through the lower jaw. It is constructed from the same durable material as the blades.



## Key differences to the C series

- 1 Bolt-on, Replaceable Wear Plate
- 2 Weld-on Piercing Tip

# S305: for Skid Steer Loaders and Mini-Excavators



The S305 Mobile Scrap and Demolition Shear, mounted on a mini-excavator or skid steer loader is a very productive tool in processing of lighter steel or non-ferrous material such as cable, rebar, small beams and small diameter pipe.

The S305 is designed for use on skid steer loaders and mini-excavators creating a cutting system that keeps machine stability and productivity in mind. The S305 is matched to the machine's horsepower and auxiliary hydraulic circuit for maximum system performance and reliability.

The S305 is designed and matched for maximum performance on skid steer loaders sized 236B2 and larger, all multi-terrain loaders, boom-mount on the 303.5, 304, 305; stick-mount on 307 and 308 hydraulic excavators.

## Key features

- 1 Heavy duty 360° rotation system**  
Designed to withstand forces mini-Excavators and Skid Steer Loaders are capable of applying to the rotator area.
- 2 Fully reversable knives**  
Four cutting edges each
- 3 Rotation jaw lock**
- 4 Hub nut pin is field replaceable**



# Specifications and Dimensions

		S305	S320B	S325B	S340B	S365C	S385C
Weight*, boom-mount	kg	608	2570	3390	4695	6870	8320
Weight*, stick-mount	kg	580	2165	2996	4386	6700	7975
<b>A</b> Length	mm	1709	2792	3177	3638	3840	4260
<b>B</b> Height	mm	660	1340	1525	1720	1900	2120
<b>C</b> Width	mm	390	792	792	975	1180	1400
<b>D</b> Jaw opening	mm	240	409	528	563	845	879
<b>E</b> Jaw depth	mm	290	459	571	703	840	903
Jaw width (fixed)	mm	230	304	342	396	466	466
Jaw width (moving)	mm	60	90	100	120	150	150
<b>Shear forces</b>							
Tip	kN	385	892	1274	1558	2008	2481
Primary blade center	kN	653	1583	2221	2751	3754	4696
At throat	kN	1812	3706	5562	6818	10342	12509
<b>Hydraulic for cutting</b>							
Max. operating pressure	bar	250	350	350	350	350	350
Recommended flow	l/min	100	150	200	300	530	690
Opening time jaw	sec	3.5	4	5	5	5	5
Closing time jaw	sec	2.5	2	3	3	3	3
<b>Hydraulic for rotating</b>							
Max. operating pressure	bar	100	140	140	140	140	140
Recommended flow	l/min	20	40	40	40	80	80
<b>Cutting guide**</b>							
I beams		IPN 200	IPE 360	IPE 400	IPE 450	IPE 600	IPE 600
Columns		HE 120 A	HP 200x53	HE 240 B	HE 300 B	HE-A 450	HE 450 B
Round	mm	50	90	100	115	120	125
Square	mm	40	65	90	90	100	120
Pipe		DN 200	DN 300	DN 350	DN 400	DN 458	DN 508
Piercing	mm	10	16	19	22	27	33

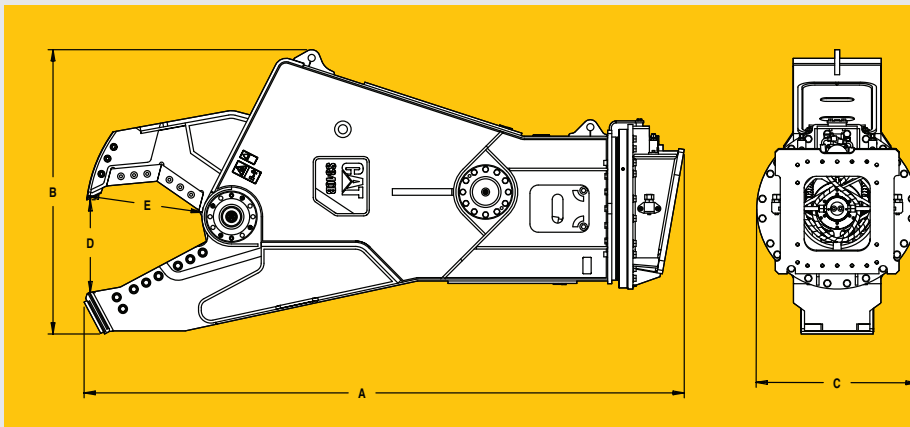

\* Weight includes mounting bracket.

\*\* The profiles above provide an approximation of shear cutting capabilities. Cutting capacities shown are based on material made of mild steel, HEX operating pressure of 350 bar, and shear knives in good condition. Lower operating pressures, dull blade edges, and harder steel will reduce cutting capacities.

## Hydraulic Requirements

Two way hydraulic high pressure lines for opening/closing and two way hydraulic medium pressure lines for rotation controlled by joystick in the cab or pedal according to customer's choice.

## Matching Guide – Hydraulic Excavators

Sheers	HEX - stick mount	HEX - boom mount	Ultra High Demolition
S305	307D		
S320B	M315D, 308D CR, M316D, M318D, 319DL, 320DL, M322D, 323DL, 324DL, 329DL	M313D, M315D, M316D, M318D, 312DL	325D, 330D, 345C, 365C, 385C DEM50, DEM70
S325B	324DL, 329DL, 336DL	M313D, M315D, 315DL, M316D, M318D, 319DL, 320DL, M322D, 323DL, M318DMH, M322DMH	325D, DEM50
S340B	345D	M318DMH, M322D, M322DMH, 324DL, M325DMH, M325DLMH, 329DL	
S365C		330DL, 336DL, 345DL, 365C, 374DL	
S385C		365C, 374D, 385C	

Matches indicated above are based on counterweight and grouser width on standard machines. Using different counterweight and grouser options may affect machine stability. Matches indicated above are calculated with standard boom (1-piece or Reach), pin on connection and, cases where this is applicable, with all four stabilizers down. Any variation from this could result in a less than stable match. For Cat shears matched to machine and other machine variations not listed above, please contact your local Cat dealer.

### Boom-mount



Cat Shears can be boom-mounted for use in scrap yards and other applications where a large shear is required to reduce metal and reach is not as important.

### Stick-mount



Cat Shears are commonly stick-mounted for use in demolition applications where reach is critical.

The shear can be pinned directly to the stick, or utilized with either a pin grabber quick coupler or dedicated coupler. The addition of a coupler allows quick tool change and is ideal for situations in which multiple tool options are desired.

For more complete information on Cat products, dealer services, and industry solutions, visit us on the web at [www.cat.com](http://www.cat.com)

HEHX4384-0 (08/2010) hr

© 2010 Caterpillar -- All Rights Reserved

Materials and specifications are subject to change without notice. Featured machines in photos may include additional equipment. See your Caterpillar dealer for available options.

CAT, CATERPILLAR, their respective logos, "Caterpillar Yellow" and the POWER EDGE™ trade dress, as well as corporate and product identity used herein, are trademarks of Caterpillar and may not be used without permission.

**CATERPILLAR®**  
TODAY'S WORK. TOMORROW'S WORLD.™