

Shown with
Accessory Equipment

SPECIFICATIONS

In-Line 8, 4-Stroke-Cycle-Diesel

Emissions	IMO II/EPA Tier 2 compliant
Displacement	148 L (9,031 cu. in.)
Low Idle Speed	350 rpm
Rated Speed	900 rpm
Bore	280 mm (11.0 in.)
Stroke	300 mm (11.8 in.)
Compression Ratio	13:1
Aspiration	Turbocharged-Aftercooled Governor
Cooling System	Keel or Heat Exchanger
Weight, Dry	19,000 kg (41,800 lbs)
Refill Capacities	
Cooling System	1030-1205 L (272-318 gal)
Lube Oil System	760 L (201 gal)
Oil Change Interval*	925 hours
Rotation (from flywheel end)	CCW or CW
Serial Number Prefix	PKA

*A new S•O•SSM analysis must be done to determine actual oil change intervals.

STANDARD ENGINE EQUIPMENT

Air Intake and Exhaust System

Charge air cooler, air inlet shutoff, high flow turbocharger, dry manifold with soft or hard shielding

Basic Engine Arrangement

In-line engine with one-piece grey iron cylinder block, individual cylinder heads with four intake/exhaust valves, right- or left-hand service side available

Control System

Dual ADEM™ A3 electronic engine control unit (ECU) with electronic unit injector fuel system, rigid wiring harness (10 amp, 24 volt power required to drive ECU)

Cooling System

Single or combined system, engine mounted freshwater and seawater pumps, engine coolant water drains

Fuel System

Engine operates on MDO; fuel injection system consists of engine-driven fuel transfer pump and an electronic unit injector for each cylinder, engine-mounted duplex fuel filters, and flexible connections

Lube Oil System

Top-mounted crankcase breather, two centrifugal oil filters with single shutoff, gear-driven pump, duplex oil filter, crankcase explosion relief, oil filler and dipstick

Monitoring, Alarm, and Safety Control System

Alarms and shutdowns provided as required by marine society for unmanned machinery spaces. Marine Monitoring System II [list as Programmable Logic Control (PLC) in the Price List] or Engine Control Panel are available; systems include temperature, pressure, and speed sensors; optional: oil mist detector or particle detector available

ECU Functions

Key-switch, desired engine speed, programmable low idle, SAE J1939 data link, Cat® data link, Messenger (displays engine data, diagnostics, etc.), diagnostics, general alarm, programmable parameters (system, application, and tattletales), Cat ET service tool interface, remote shutdown, shutdown notify, load feedback, overspeed shutdown, overspeed verify, engine power correction, droop, dual dynamics

General

Four lifting eyes mounted to cylinder heads, Cat yellow paint, parts books and maintenance manuals, shrink wrap

Optional Supplied Equipment

Torsional coupling, fresh water heat exchanger, fuel cooler, expansion tank, emergency pumps and connections, jacket water heater, flexible connections, and anti-vibration isolators

MARINE ENGINE PERFORMANCE

C280-8

DIESEL ENGINE TECHNICAL DATA



RATED SPEED (RPM): 900
 RATED POWER¹ (bkW): 2300
 BMEP @ 100% LOAD (kPa): 2076
 COMPRESSION RATIO: 13:1
 AFTERCOOLER WATER (°C): 32
 JACKET WATER OUTLET (°C): 90
 IGNITION SYSTEM: EUI
 FIRING PRESSURE, MAXIMUM (kPa): 16200

ENGINE RATING: **Marine CSR**
 CERTIFICATION⁵: IMO II/EPA MARINE TIER II
 TURBOCHARGER PART #: 284-8280
 COMBUSTION: DI
 FUEL TYPE: Distillate
 EXHAUST MANIFOLD: DRY
 MEAN PISTON SPEED (m/s): 9

Engine Performance

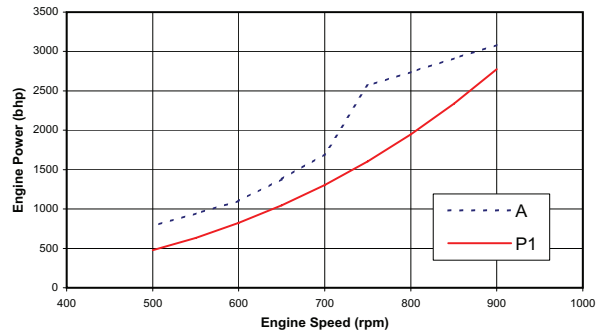
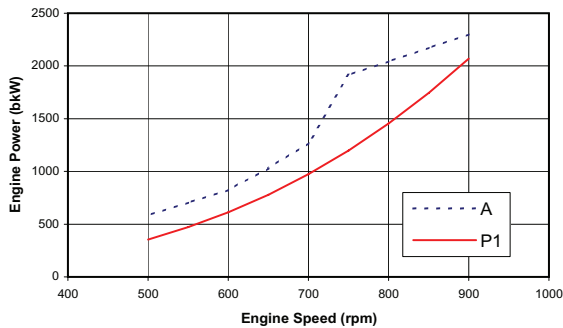

ZONE LIMIT DATA								
Engine Speed rpm	Power bkW	Fuel Cons ³ g/kW-hr	Fuel Rate L/hr	Boost Press kPa Gauge	Air Flow ⁴ cu m/Min	Exh Temp to Turbo C	Exh Stack Temp C	Exh Flow cu m/min
900	2300	207	568.2	265	251.7	543	364	530.4
850	2172	209	540.3	260	240.9	543	367	510.3
800	2044	209	508.5	250	226.1	543	372	482.1
750	1917	196	446.9	209	192.3	528	373	411.1
700	1266	203	306.7	124	132.9	517	399	295.5
650	1029	202	248.1	77	97.8	530	431	228.3
600	822	209	204.5	50	76.3	540	450	183.5
550	705	215	180.6	35	68.4	540	455	165.3
500	587	218	152.7	24	51.6	538	458	125.8

ZONE LIMIT DATA								
Engine Speed rpm	Power bhp	Fuel Cons ³ lb/hp-hr	Fuel Rate gal/hr	Boost Press in Hg-Gauge	Air Flow ⁴ cfm	Exh Temp to Turbo F	Exh Stack Temp F	Exh Flow cfm
900	3084	0.341	150.0	78	8889	1009	687	18732
850	2913	0.344	142.7	77	8508	1009	693	18020
800	2742	0.344	134.3	74	7983	1010	701	17026
750	2570	0.322	118.0	62	6790	982	703	14517
700	1698	0.335	81.0	37	4693	962	750	10435
650	1380	0.333	65.5	23	3453	985	807	8062
600	1103	0.343	54.0	15	2696	1005	843	6480
550	945	0.354	47.7	10	2414	1004	851	5838
500	787	0.359	40.3	7	1823	1000	856	4443

PROPELLER DEMAND DATA								
Engine Speed rpm	Power bkW	Fuel Cons ³ g/kW-hr	Fuel Rate L/hr	Boost Press kPa Gauge	Air Flow ⁴ cu m/Min	Exh Temp to Turbo C	Exh Stack Temp C	Exh Flow cu m/min
900	2070	214	527.3	253	242.4	529	358	505.3
850	1744	210	437.2	213	210.3	500	348	430.8
800	1454	206	356.7	167	172.7	485	352	356.2
750	1198	204	291.6	119	135.2	483	373	288.7
700	974	206	239.6	81	104.8	493	398	232.7
650	780	211	196.0	51	80.9	500	416	184.7
600	613	214	156.8	31	63.9	484	411	145.1
550	472	216	121.6	14	53.2	404	383	115.4
500	355	216	91.3	9	42.1	388	344	85.7

PROPELLER DEMAND DATA								
Engine Speed rpm	Power bhp	Fuel Cons ³ lb/hp-hr	Fuel Rate gal/hr	Boost Press in Hg-Gauge	Air Flow ⁴ cfm	Exh Temp to Turbo F	Exh Stack Temp F	Exh Flow cfm
900	2776	0.352	139.2	75	8559	984	676	17846
850	2338	0.346	115.4	63	7428	932	658	15214
800	1950	0.339	94.2	49	6100	904	666	12580
750	1606	0.336	77.0	35	4776	902	704	10196
700	1306	0.340	63.3	24	3700	920	749	8219
650	1046	0.347	51.7	15	2857	931	781	6524
600	822	0.353	41.4	9	2258	903	773	5123
550	634	0.356	32.1	4	1878	759	721	4075
500	476	0.355	24.1	3	1485	730	651	3026

Heat Rejection @ 100% Load and 25° C Air

Lube Oil Cooler	kW (Btu/min)	242 (13770)
Jacket Water	kW (Btu/min)	484 (27540)
AfterCooler	kW (Btu/min)	468 (26629)
Total Heat Rejection to Raw Water	kW (Btu/min)	1194 (67939)
Exhaust Gas ²	kW (Btu/min)	1804 (102648)
Radiation	kW (Btu/min)	114 (6487)

Notes

- 1 Ratings are based on ISO 3046/1 and SAEJ1995 Jan 90 standard reference conditions of 100 kPa, 25° C, and 30% relative humidity at the stated aftercooler water temperature.
- 2 Exhaust Heat rejection is based on fuel LHV and is not normally recoverable in total
- 3 At 100% load with JW and Oil pumps, without seawater pump, +/- 3%. Performance and fuel consumption are based on 35 API, 16°C fuel having a lower heating value of 42,780 kJ/kg used at 29°C with a density of 838.9 g/liter.
- 4 Air flows are shown for 25°C air inlet to the turbocharger and 32°C cooling water to the charge air cooler.
- 5 This engine's exhaust emissions are in compliance with the INTERNATIONAL MARINE ORGANIZATION'S (IMO) standard as described in REGULATION 13 of ANNEX VI of MARPOL 73/78 and ISO 8178 for measuring HC, CO, PM, and NOx.

DM8397-01

3/4/10

ENGINE DIMENSIONS

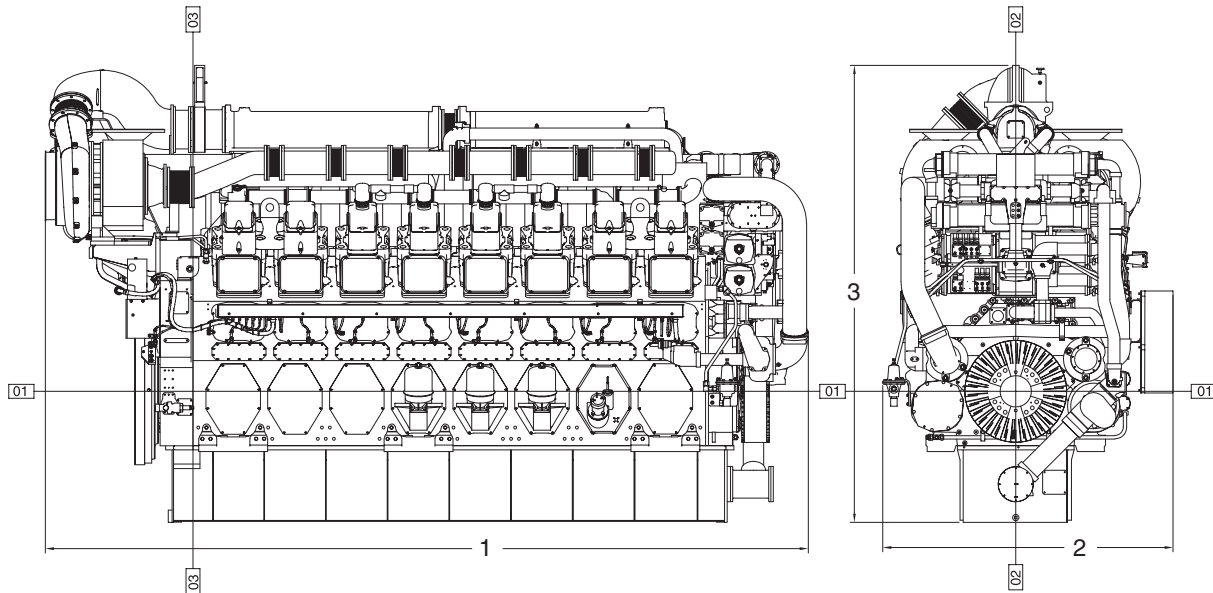

Engine Dimensions		
(1) Overall Length	4958 mm	195.2 in.
(2) Overall Width	1804 mm	71.0 in.
(3) Overall Height	2648 mm	104.2 in.

Note: Do not use for installation design. See general dimension drawings for detail.

Engine Weights		
Engine Dry Weight	19,000 kg	41,800 lb
Shipped Loose Items		
Torsional Coupling	319 kg	702 lb
Plate-Type Heat Exchanger	420 kg	924 lb
Instrument/Alarm Panel	200 kg	440 lb
Fluids		
Lube Oil	691 kg	1,520 lb
Jacket Water	530 kg	1,166 lb
Heat Exchanger (FW, SW, LO)	70 kg	154 lb

RATING DEFINITIONS AND CONDITIONS

Continuous Service Rating — 100% of the engine operating hours at 100% of rated power.

Ratings are based on SAE J1995/ISO3046 standard conditions of 100 kPa (29.61 in. Hg), 25°C (77°F), and 30% relative humidity at the stated charge air cooler water temperature. Ratings also meet classification society maximum temperature requirements of 45°C (113°F) air temperature to the turbocharger and 32°C (90°F) seawater temperature without derate.

Additional ratings may be available for specific customer requirements. Consult your Cat representative for additional information.

Fuel rates are based on 35° API, 16°C (60°F) fuel used at 29°C (85°F) with a density of 838.9 g/liter (7.001 lbs/U.S. gal). Lower Heat Value (LHV) of 42 780 kJ/kg (18,390 Btu/lb). Tolerance is +5%. Includes all engine mounted pumps. BSFC without pumps is 3% less.

Marine Certification — Ratings are marine classification society approved by ABS, BV, CCS, DnV, GL, KR, LRS, NKK, RINA, and RS. These societies have also granted C280 factory line production approval which eliminates requirement for society surveyor witness test.

Performance data is calculated in accordance with tolerances and conditions stated in this specification sheet and is only intended for purposes of comparison with other manufacturers' engines. Actual engine performance may vary according to the particular application of the engine and operating conditions beyond Caterpillar's control.

Power produced at the flywheel will be within standard tolerances up to 49°C (120°F) combustion air temperature measured at the air cleaner inlet, and fuel temperature up to 52°C (125°F) measured at the fuel filter base. Power rated in accordance with NMMA procedure as crankshaft power. Reduce crankshaft power by 3% for propeller shaft power.

CAT, CATERPILLAR, their respective logos, ADEM, S•O•S, "Caterpillar Yellow" and the "Power Edge" trade dress, as well as corporate and product identity used herein, are trademarks of Caterpillar and may not be used without permission.