



# Cat<sup>®</sup> CS56B

## SMOOTH DRUM VIBRATORY SOIL COMPACTOR

### FEATURES:

The Cat<sup>®</sup> CS56B features a smooth drum and is ideally suited for granular soil applications or cohesive soil applications with the use of an optional padfoot shell kit:

- **Comfortable and ergonomic operator station** features pivoting seat with integrated multifunction LCD display and control console, outstanding visibility to the front and rear of machine, low sound levels and vibration for greater operator comfort and productivity.
- **World-class propel system** built around the exclusive Cat dual pump propel system, two pumps provide separate dedicated flow to drum drive motor and rear axle motor for exceptional gradeability and traction in forward and reverse. New electronic propel control provides more precise machine control.
- **Virtually maintenance free** due to maintenance-free hitch bearings and extended maintenance intervals for vibratory system and hydraulic system, providing more uptime and lower maintenance costs.
- **Enhanced compaction performance** due to more weight at the drum and greater amplitude. Automated speed control and vibratory system functions make it easy to ensure consistent, high quality compaction.
- **Optional Cat Compaction Control** helps the operator determine when compaction has been completed to specification for greater productivity and uniform compaction quality. CMV or exclusive Machine Drive Power (MDP) measurement technology available.

## Specifications

### Engine - Power Train

Engine Model	Cat C6.6 with ACERT™	
Global Emissions	US EPA Tier 3/EU Stage IIIA	
Gross Power ISO 14396	116.5 kW	156 hp
Displacement	6.6 L	402.8 in <sup>3</sup>
Stroke	127 mm	5 in
Bore	105 mm	4.1 in
Max. Travel Speed (Forward or Reverse)	11.4 km/h	7 mph
Theoretical Gradeability, no vibration*	57%	

### Weights

Operating Weight w/ open platform	10 970 kg	24,185 lb
Operating Weight w/ steel sun canopy	11 065 kg	24,394 lb
Operating Weight w/ ROPS/FOPS canopy	11 235 kg	24,769 lb
Operating Weight w/ ROPS/FOPS cab	11 555 kg	25,474 lb
Weight at Drum w/ open platform	6135 kg	13,525 lb
Weight at Drum w/ steel sun canopy	6165 kg	13,592 lb
Weight at Drum w/ ROPS/FOPS canopy	6220 kg	13,713 lb
Weight at Drum w/ ROPS/FOPS cab	6355 kg	14,010 lb

#### Additional Weight with:

Oval Padfoot Shell Kit	+ 1730 kg	+ 3,814 lb
Square Padfoot Shell Kit	+ 1880 kg	+ 4,145 lb
Leveling Blade	+ 620 kg	+ 1,373 lb

### Vibratory System Specifications

Frequency		
Standard	30.5 Hz	1830 vpm
During Eco-mode Operation	27.7 Hz	1664 vpm
Optional Variable Frequency	23.3-30.5 Hz	1400-1830 vpm
Nominal Amplitude @ 30.5 Hz (1830 vpm)		
High	2.1 mm	0.083 in
Low	0.98 mm	0.039 in
Centrifugal Force @ 30.5 Hz (1830 vpm)		
Maximum	301 kN	67,600 lb
Minimum	141 kN	31,670 lb
Static Linear Load		
w/ open platform	28.7 kg/cm	161 lbs/in
w/ steel sun canopy	28.9 kg/cm	161.8 lbs/in
w/ ROPS/FOPS canopy	29.1 kg/cm	163.3 lbs/in
w/ ROPS/FOPS cab	29.8 kg/cm	166.8 lbs/in

### Service Refill Capacities

Fuel Tank, total capacity	242 L	64 gal
Cooling System	27.9 L	7.4 gal
Engine Oil w/ Filter	17.4 L	4.6 gal
Eccentric Weight Housings	26 L	6.9 gal
Axle and Final Drives	18 L	4.8 gal
Hydraulic Tank (service refill)	50 L	13.2 gal

\* Actual gradeability may vary based on site conditions and machine configuration. Refer to the Operation and Maintenance Manual for more information.



# CS56B Vibratory Soil Compactor

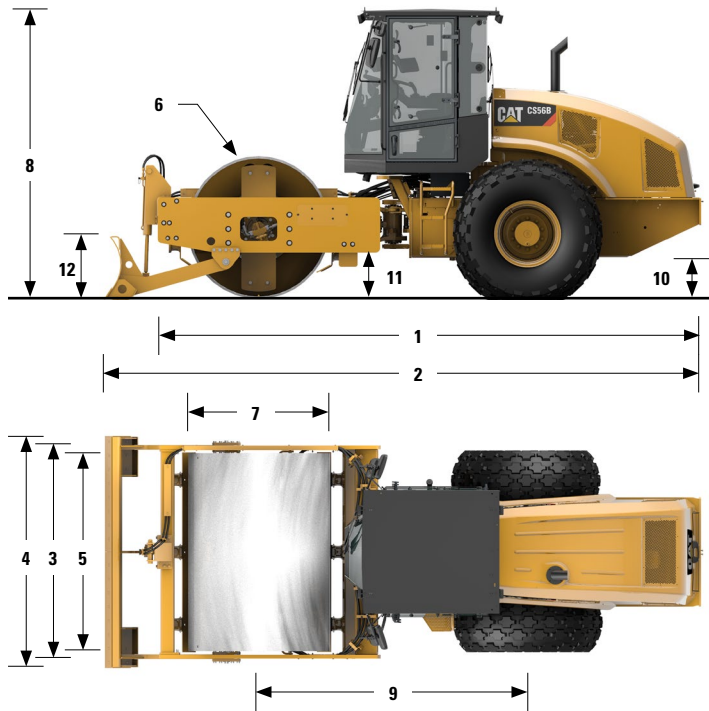

## Dimensions

1 Overall Length	5.86 m	19.2 ft
2 Overall Length w/ optional Leveling Blade	6.4 m	20.9 ft
3 Overall Width	2.30 m	7.53 ft
4 Overall Width w/ optional Leveling Blade	2.50 m	8.25 ft
5 Drum Width	2134 mm	84 in
6 Drum Shell Thickness	30 mm	1.18 in
7 Drum Diameter	1534 mm	60.4 in
8 Overall Height	3.11 m	10.2 ft
9 Wheelbase	2.9 m	9.5 ft
10 Ground Clearance	442 mm	17.4 in
11 Curb Clearance	494 mm	19.3 in
12 Optional Leveling Blade Height	688 mm	27.1 in
Inside Turning Radius	3.68 m	12.07 ft
Hitch Articulation Angle	34°	
Hitch Oscillation Angle	15°	

## STANDARD EQUIPMENT *Varies by market- contact your dealer for specifics.*

### ELECTRICAL

- 24 volt Electrical System
- 100 ampere Alternator
- 750 Cold-cranking Amps Battery Capacity

### OPERATOR ENVIRONMENT

- Open Platform with Handrails/Guardrails, Floor Mat
- Vinyl Adjustable Pivoting Seat with Integrated Console and LCD Display
- Multifunction LCD Display with gauges and audible warning for: *Hydraulic oil temperature, Engine oil pressure, Engine coolant temperature, Alternator charge, Fuel level, Service hour meter, Engine RPM, Ground speed, Vibe frequency, Fuel rate, Air filter constriction, Engine load and Optional Cat Compaction Control*
- Adjustable Tilting Steering Column with Integrated Cup Holders
- Seat Belt
- 12-volt Power Outlet
- Interior Rear View Mirror
- Horn, Backup Alarm

### POWER TRAIN

- Cat C6.6 Diesel Engine
- Air Cleaner, Dual Element
- Three-speed Throttle Switch, Eco-mode and Automatic Speed Control
- Dual Propel Pumps; One for Drum Drive, One for Rear Axle
- Fuel Filter, Water Separator, Priming Pump, Water Indicator
- Tilting Radiator/Hydraulic Oil Cooler
- Dual Braking System
- Two-speed Hydrostatic Transmission

### VIBRATORY SYSTEM

- Smooth Drum
- Dual Amplitude, Single Frequency
- Dual Pod-Style Eccentric Weight Housings
- Auto-vibe Function
- Front Adjustable Steel Scrapers

### OTHER

- Sight Gauges for Hydraulic Oil Level and Radiator Coolant Level
- S-O-S<sup>SM</sup> Sampling Valves: Engine Oil, Hydraulic Oil and Coolant

### OPTIONAL EQUIPMENT

- Steel Sun Canopy
- ROPS/FOPS Canopy
- ROPS/FOPS Cab with Climate Control
- Padfoot Shell Kit (oval or square pads available)
- Leveling Blade
- Variable Vibration Frequency
- Beacon, Rotating
- Polyurethane Drum Scrapers
- Steel Rear-side Drum Scraper
- Sun Visor
- Cat Compaction Control, Machine Drive Power or CMV
- SBAS GNSS Mapping for Cat Compaction Control (RTK available)
- Upgraded Halogen Light Package
- Cab Internal Rear View Mirrors
- Cab Internal Roll-down Sun Screen
- Product Link<sup>TM</sup>
- Additional Rear View Mirrors
- Containerized Shipping
- Fuel Fill Access Door
- Transmission Guard

For more complete information on Cat products, dealer services, and industry solutions, visit us on the web at [www.cat.com](http://www.cat.com)

QEHQ1653-05 (01-16)  
LRC

© 2016 Caterpillar  
All Rights Reserved  
Printed in U.S.A.

Materials and specifications are subject to change without notice. Featured machines in photos may include additional equipment. See your Cat dealer for available options.

CAT, CATERPILLAR, BUILT FOR IT, their respective logos, "Caterpillar Yellow" and the "Power Edge" trade dress, as well as corporate and product identity used herein, are trademarks of Caterpillar and may not be used without permission.

