

R1600H

Underground Mining Loader



Engine

Engine Model	Cat® C11 ACERT™	
Gross Power – VR Engine – SAE J1995	208 kW	279 hp
Gross Power – Tier 3 Engine – SAE J1995	208 kW	279 hp

Operating Specifications

Nominal Payload Capacity	10 200 kg	22,487 lb
Gross Machine Mass	44 204 kg	97,453 lb
Bucket Capacities		
Bucket Capacities	4.2-5.9 m ³	5.5-7.7 yd ³

R1600H Features

One Supplier

Caterpillar designed and manufactured major power and drive train components for reliability and performance.

Reliable and Durable Engine

The Cat C11 engine offers the perfect balance between power, robust design and economy.

Power Shift Transmission

Reliable and rugged design to deliver power and efficiency for peak power train performance.

Hydraulics

Perfect balance between low effort controls and powerful hydraulics for smooth and fast cycle time.

Durable Structures

The heavy duty frame is designed and built to absorb twisting, impact and high loading forces.

Comfortable Cab

Ergonomically designed for all-day comfort, control and productivity.

Enhanced Serviceability

Designed with improved service points and grouped service locations to simplify maintenance and repair.

Built in Safety

Safety is not an after thought, but an integral part of all machine and system design.

Contents

Power Train – Engine	4
Power Train – Transmission	5
Hydraulics	6
Structures.....	7
Operator Comfort	8
Loader Bucket Systems	9
Serviceability	10
Customer Support.....	11
Safety	12
Specifications.....	13
Standard Equipment.....	16
Optional Equipment.....	17





The R1600H underground loader is designed to meet the challenges of the most demanding underground mining applications. Compact design with agile performance, rugged construction and simplified maintenance ensures excellent productivity, long life and low operating costs.

Engineered for performance, designed for comfort, built to last.

Power Train – Engine

The Cat C11 engine with ACERT Technology.
Innovative technologies optimize performance.

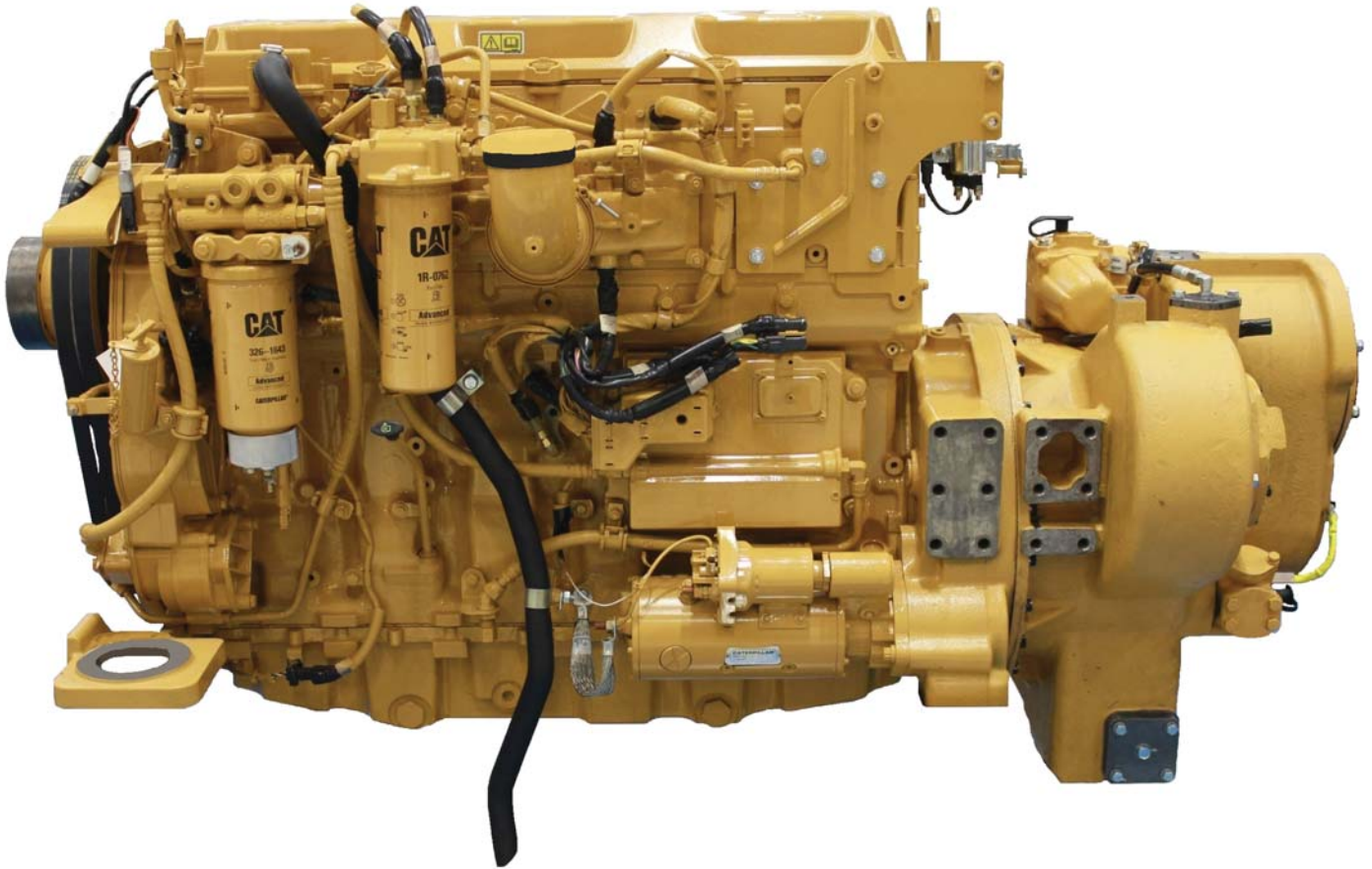

The Cat C11 engine provides unequalled lugging force while digging, tramming and traversing steep grades. Torque rise effectively matches transmission shift points for maximum efficiency and fast cycle times. Mechanically Actuated, Electronic Unit Injection (MEUI™) high-pressure, direct injection fuel system electronically monitors operator demands and sensor inputs to optimize engine performance. Air-to-air aftercooling provides improved fuel economy by packing cooler, denser air into cylinders for more complete combustion of fuel and lower emissions. Oil cooled pistons increase heat dissipation and promote longer piston life. The crankshaft is forged and induction hardened for long-term durability.

The Cat C11 engine features the optional Ventilation Reduction Package. The VR Package incorporates selective engine hardware and software to minimize diesel particulate matter in the engine exhaust. Engines equipped with the VR Package feature a significant ventilation rate reduction, maintains fuel consumption, and maintained or improved product performance. VR Package availability is subject to regional regulatory compliance. Optional U.S. EPA Tier 3 and EU Stage III equivalent engine is also available.

A Cat Diesel Particulate Filter can be used with the VR engine package. This filter compliments the VR engine by further reducing particulate matter in the exhaust. Requires the use of 15 PPM ultra low sulfur diesel and CJ-4 low ash engine oil.

Power Train – Transmission

More power to the ground
for greater productivity.

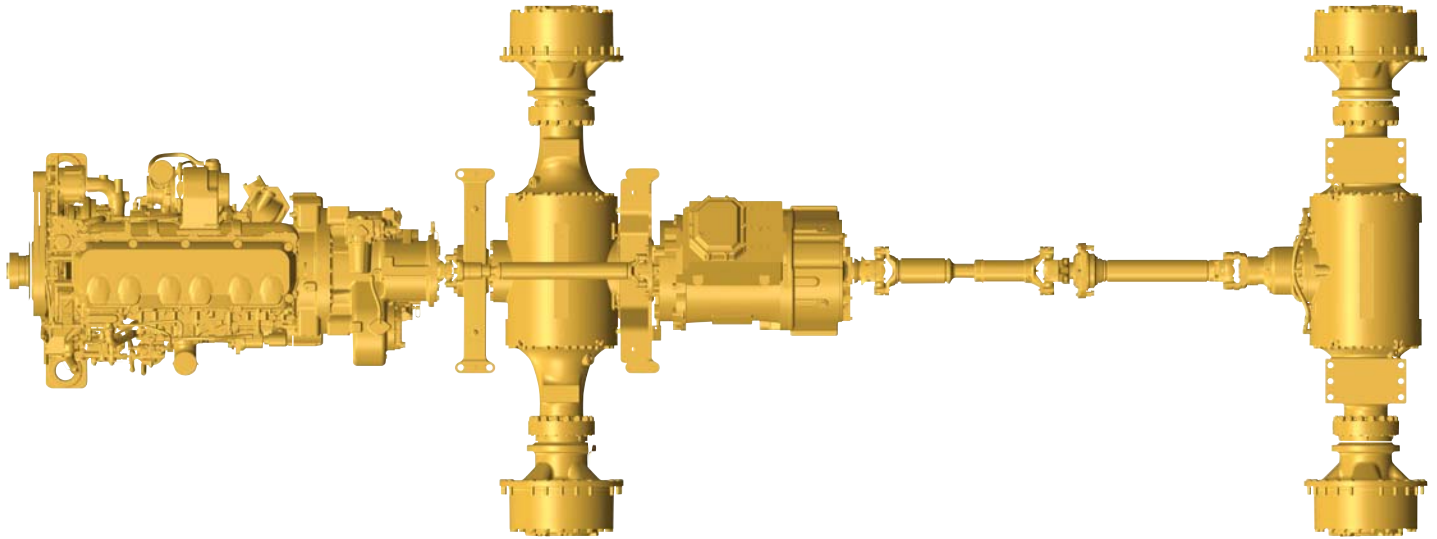

Power Shift Transmission

The Cat four-speed planetary power shift transmission is matched with the Cat C11 diesel engine to deliver constant power over a wide range of operating speeds and grades.

Robust Design

Designed for rugged underground mining conditions, the proven planetary power shift transmission is built for long life between overhauls.

Torque Converter Lockup Clutch

Combines maximum rimpull while in torque converter drive with the efficiency and performance of direct drive when the lockup clutch is engaged. The lockup clutch delivers more power to the wheels for superior power train efficiency.

Electronic Auto Shift Transmission

The electronic auto shift transmission increases operator efficiencies and optimizes machine performance. The operator can choose between manual or auto shift modes.

Transmission Neutralizer

The operator can engage the service brakes and neutralize the transmission, maintaining high engine rpm for full hydraulic flow, enhancing digging and loading functions.

Final Drives

Cat final drives work as a system with the planetary power shift transmission to deliver maximum power to the ground. Built to withstand the forces of high torque and impact loads.

Oscillating Rear Axle

Oscillating rear axle ensures four-wheel ground contact for maximum traction and stability at all times.

Brakes

Fully enclosed oil immersed disc brakes incorporate independent service and parking brake pistons. Hydraulic actuated independent circuits provide improved performance and reliability.

Hydraulics

Cat hydraulics deliver the power and control to keep material moving.



Hydraulic System

Powerful Cat hydraulics deliver exceptional digging and lifting forces for fast cycle times. High hydraulic flow rates provide fast hydraulic cylinder response and powerful lift forces. Large-bore lift and tilt cylinder delivers exceptional strength, performance and durability.

Pilot Controls

Low effort, pilot operated joystick implement control with simultaneous lift and tilt functions optimizes operating efficiency.

Cat Hydraulic Hose

Field proven Cat high pressure XT hydraulic hoses are exceptionally strong and flexible for maximum system reliability and long life in the most demanding conditions. Reusable couplings with O-ring face seals provide superior, leak free performance.

Optional Ride Control

The optional ride control system uses a nitrogen filled oil accumulator in the hydraulic lift circuit to act as a shock absorber for the bucket and lift arms. The lift arm and bucket response to movement is dampened over rough ground, reducing fore and aft pitch, improving cycle times and load retention. A smoother, more comfortable ride gives operators the confidence to travel at speeds above 5 km/h (3 mph) during load and carry operations.

Structures

Rugged Cat structures – the backbone of the R1600H's durability.

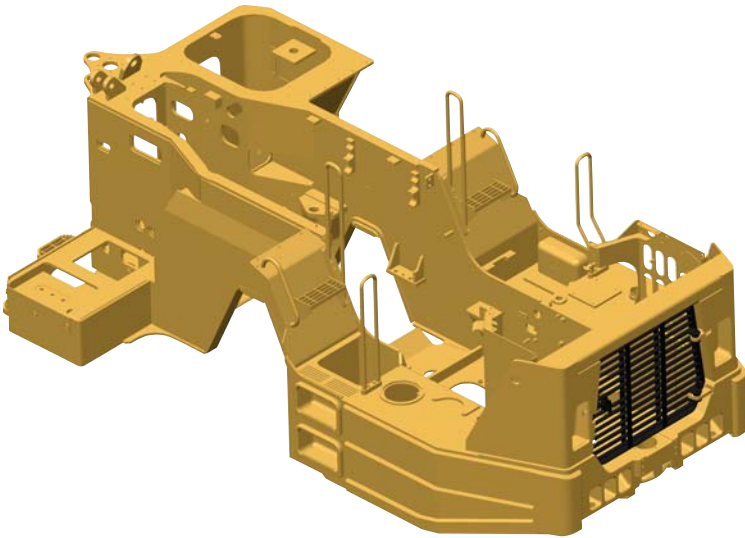

Frame Design

The frame is engineered to withstand extreme forces generated during loading and tramming cycles. Precision manufacturing process ensures all structures are consistently built to high quality. Deep penetration and consistent welds throughout the frame ensures structures are solidly fused to provide sturdy platform for the linkage and the axles. The design and manufacturing quality of Cat LHD frames have been proven by our customers, many of whom reuse frames during machine rebuilds to get 2nd and 3rd lives out of their LHD's.

Hitch

Spread hitch design widens the distance between upper and lower hitch plates to distribute forces and increase bearing life. Thicker hitch plates reduce deflection. The wide opening provides easy service access. Upper and lower hitch pins pivot on roller bearings to distribute horizontal and vertical loads over a greater surface area. Shim adjusted preload reduces maintenance time. An on-board steering frame lock pin is fitted to prevent articulation during maintenance and service.

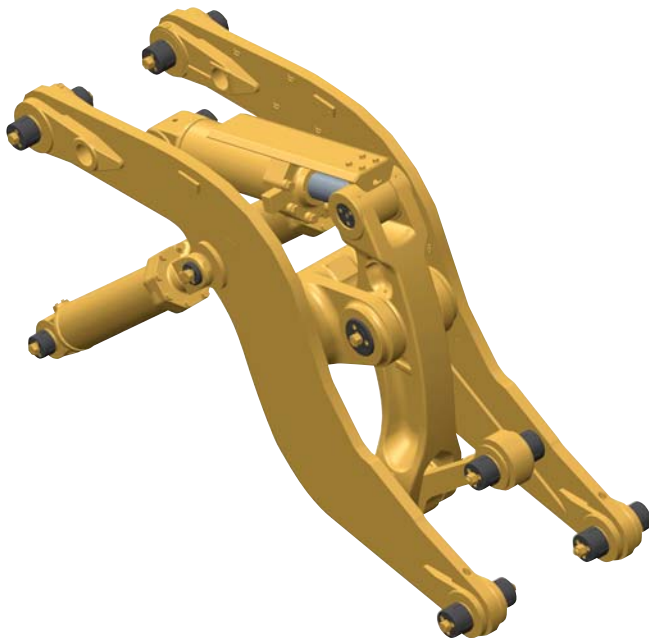

Sealed Pins

Sealed colleted pins are fitted to all bucket and lift arm hinge points for longer pin and bushing life. This reduces maintenance costs and extends service intervals. The sealed joints retain lubrication and prevent contaminant entry.

Z-bar Loader Linkage

Proven Z-bar loader linkage geometry generates powerful breakout force and an increased rack back angle for better bucket loading and material retention. Heavy duty steel lift arms with cast steel cross tube ensures extreme loads encountered during loading and tramming are efficiently dissipated for long service life.

Operator Comfort

Ergonomically designed for all-day comfort, control and productivity.

The operator station is ergonomically designed for total machine control in a comfortable, productive and safe environment. All controls, levers, switches and gauges are positioned to maximize productivity and minimize operator fatigue.

Protective Structure

Integral to the cab and frame, the resiliently mounted Roll Over Protective Structure (ROPS) and the Falling Objects Protective Structure (FOPS), isolates the operator from vibration for a more comfortable ride.

Optional Enclosed Cab

Optional sound-suppressed ROPS cab provides a quiet, secure working environment. Large window openings offer excellent visibility in all directions. Air conditioning provides filtered, pressurized, temperature-controlled air for a more comfortable working environment.

STIC™ Steering and Transmission Integrated Control

STIC provides effortless control of the machine by a single controller. Simple side-to-side motion articulates the machine. Directional shifting (forward/neutral/reverse) is controlled using a three position rocker switch. The thumb operated buttons control gear selection.

Color Multi Purpose Display (CMPD)

A multi screen display unit showing various levels of machine system conditions, pressures and temperatures. Warning information displayed advising operator of problem and response required. Operator or technician can view real time information without having to use service tooling devices. Multi language options available to enable data to be read in various languages.

Pilot Controls

Low-effort pilot operated joystick controls integrate steering, transmission and implement functions for smoother, faster cycles with less operator fatigue.





Loader Bucket Systems

Rugged performance and reliability in tough underground mining applications.



Buckets

Cat LHD buckets deliver unmatched productivity and structural reliability to help lower your cost-per-ton. Buckets are available in a range of sizes to suit most material types and densities.



Optional Wear Packages

Weld-on wear plates in high wear areas are standard. Additional wear packages, including sacrificial wear strips and Cat heel shrouds protect the edges from damage and reduce the need for costly bucket rebuilds.

Bucket Selection

Cat underground loader buckets are available in two styles to meet a range of loading, hauling and dumping conditions.

- Dump buckets
- Ejector buckets

Optional Cutting Edges

Cat half arrow and cast half arrow cutting edges extend bucket life in high wear applications. Additional GET option is the Cat weld-on GET. Available weld-on GET offers more wear material to maximize system wear life and bucket protection. Downtime is also reduced by an even wear rate between corners and edge segments, allowing both to be replaced at the same time.

Serviceability

More time for production.

Service Access

Easy access to daily service points simplifies servicing and reduces time spent on regular maintenance procedures.

Ground-Level Access

Allows convenient servicing to all tanks, filters, lubrication points and compartment drains.

Electric fuel priming. Engine oil and fuel filters installed on cold side of engine.

Air Filters

Radial seal air filters are easy to change, reducing time required for air filter maintenance.

Sight Gauges

Fluid level checks are made easier with sight gauges.

Diagnostics

CMPD multi screen display along with Caterpillar Electronic Technician (Cat ET) service tool enables quick electronic diagnosis of machine performance and key diagnostic data for effective maintenance and repairs.

Sealed Electrical Connectors

Electrical connectors are sealed to lock out dust and moisture. Harnesses are covered for protection. Wires are color and number coded for easy diagnosis and repair.

Scheduled Oil Sampling

S-O-SSM helps avoid minor repairs becoming major ones. Sample point adaptors fitted standard to machine.



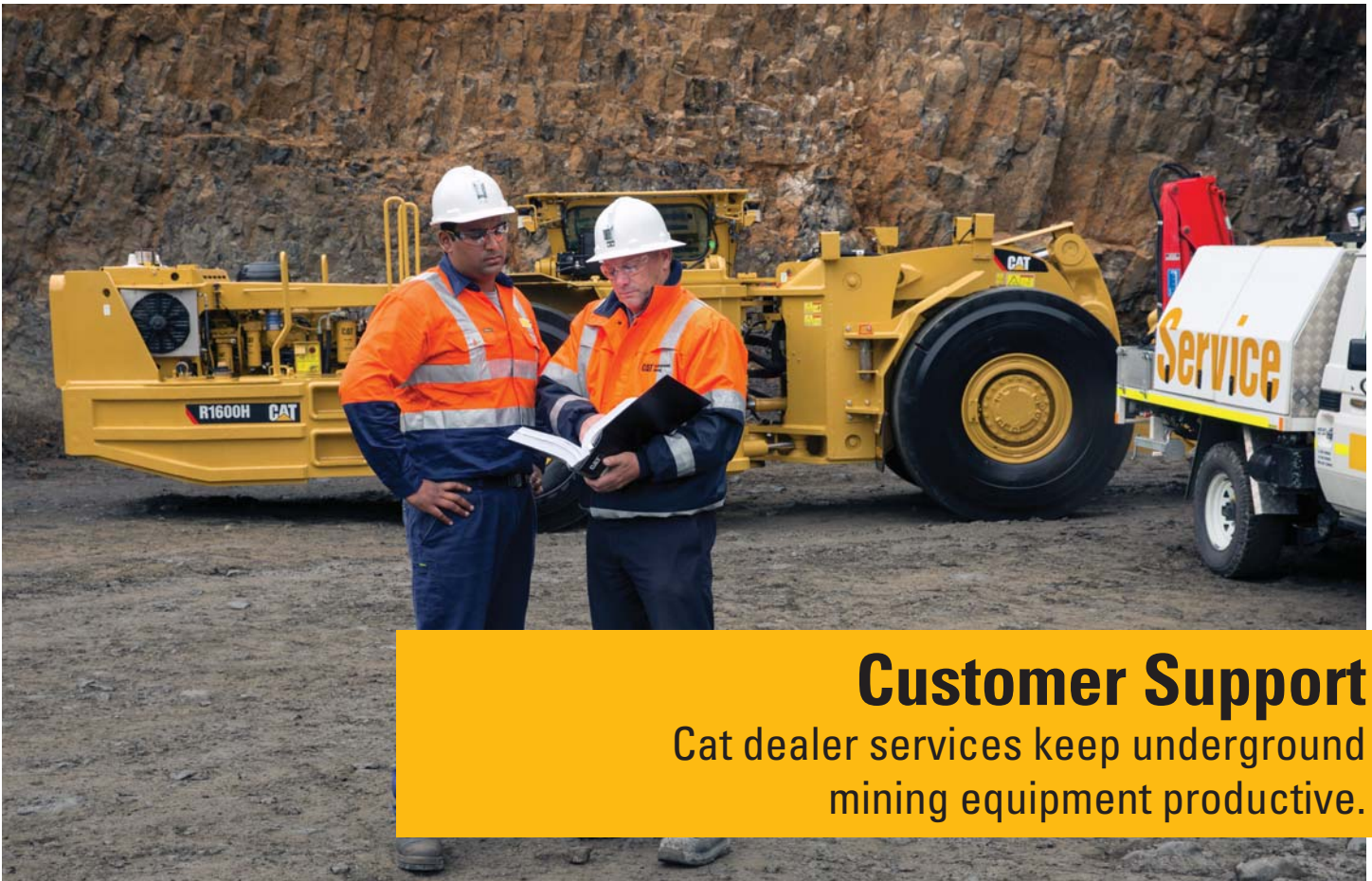

Customer Support

Cat dealer services keep underground mining equipment productive.

Dealer Capability

Cat dealers will provide the level of support you need, on a global scale. Dealer expert technicians have the knowledge, experience, training and tooling to handle your repair and maintenance needs, when and where you need them.

Product Support

When Cat products reach the field, they are supported 24/7 by a worldwide network of reliable and prompt parts distribution facilities, dealer service centers, and technical training facilities to keep your equipment up and running.

Service Support

Cat equipment is designed and built to provide maximum productivity and operating economy throughout its working life. Cat dealers will be with you every step of the way with its unsurpassed worldwide parts support, trained technicians and customer support agreements.

Technology Products

Cat dealers offer a range of advanced technology products designed to improve efficiency, productivity and lower costs. VIMS™ Gen 3 and Command for Underground options available from factory.

Replacement

Repair or rebuild? Your Cat dealer can help you evaluate the costs so you can make the right choice.

Safety

Cat mining machines and systems are designed with safety as their first priority.

Product Safety

Caterpillar has been and continues to be proactive in developing mining machines that meet or exceed safety standards. Safety is an integral part of all machine and systems designs.

Engine Shut Off Switch

3 engine shut off switches located at ground level

- Rear left hand side
- Rear right hand side
- Under operator seat

Integral ROPS Cab

Integral to the cab and frame, the ROPS is resiliently mounted to the frame to isolate the operator from vibration for a more comfortable ride.

Brake Systems

Four corner oil-cooled braking system provides excellent control. The service brake system is actuated by modulated hydraulic pressure, while the parking brake function is spring applied and hydraulic released. This system assures braking in the event of loss of hydraulic failure.

Standard Safety Features

Anti-skid upper deck surfaces, lower cab light, ground level compartment sight glasses, increased visibility, 3-point access to cab and machine, push out safety glass, suspension seat, inertia reel retractable seat belt, bucket control group safety pins, hot and cold side of engine, articulation lock, hinged belly guards.

Operator Present System

This standard system protects the machine and operator from uncontrolled machine movements.

safety.cat.com

For more information on safety, please visit <http://safety.cat.com>.

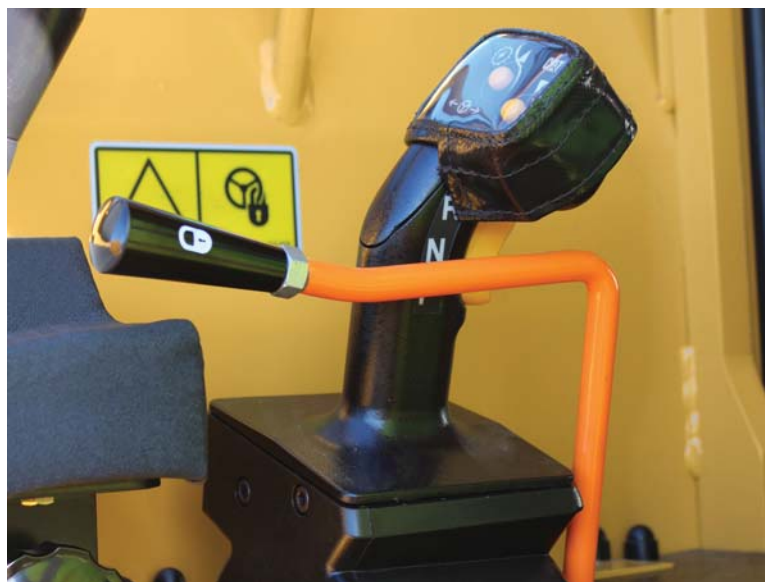

R1600H Underground Mining Loader Specifications

Engine

Engine Model	Cat C11 ACERT	
Gross Power – VR Engine – SAE J1995	208 kW	279 hp
Gross Power – Tier 3 Engine – SAE J1995	208 kW	279 hp
Bore	130 mm	5.1 in
Stroke	140 mm	5.5 in
Displacement	11.1 L	680.4 in ³

- Power ratings apply at a rated speed of 1,800 rpm when tested under the reference conditions for the specified standard.
- Ratings based on SAE J1995 standard air conditions of 25° C (77° F) and 100 kPa (29.61 Hg) barometer. Power based on fuel having API gravity of 35 at 16° C (60° F) and an LHV of 42 780 kJ/kg (18,390 BTU/lb) when engine used at 30° C (86° F).
- No engine derating required up to 3048 m (10,000 ft) for Tier 3 Engine and 1828 m (6,000 ft) for VR Engine.
- Optional Ventilation Reduction Package available.
- Optional Tier 3 engine package is equivalent to U.S. EPA Tier 3 and EU Stage III emission standards.

Operating Specifications

Gross Machine Mass	44 204 kg	97,453 lb
Static Tipping Load Straight Ahead Lift Arms Horizontal	25 905 kg	57,110 lb
Static Tipping Load Full Turn Lift Arms Horizontal	21 803 kg	46,067 lb
Breakout Force (ISO) Tilt	17 928 kg	39,524 lb
Breakout Force (ISO) Lift	19 202 kg	42,333 lb

Weights

Empty	30 150 kg	66,469 lb
Front Axle	12 884 kg	28,404 lb
Rear Axle	17 266 kg	38,065 lb
Loaded	40 350 kg	88,956 lb
Front Axle	28 128 kg	62,011 lb
Rear Axle	12 222 kg	26,944 lb

Transmission

Forward 1	5 km/h	3.1 mph
Forward 2	8.7 km/h	5.4 mph
Forward 3	15.2 km/h	9.5 mph
Forward 4	22.1 km/h	13.7 mph
Reverse 1	5.7 km/h	3.5 mph
Reverse 2	9.9 km/h	6.2 mph
Reverse 3	17.2 km/h	10.7 mph
Reverse 4	23.8 km/h	14.8 mph

Hydraulic Cycle Time

Raise	7.6 Seconds
Dump	1.6 Seconds
Lower, Empty, Float Down	2 Seconds
Total Cycle Time	11.2 Seconds

Bucket Capacities

Dump Bucket – 1	4.2 m ³	5.5 yd ³
Dump Bucket – 2 (standard bucket)	4.8 m ³	6.3 yd ³
Dump Bucket – 3	5.6 m ³	7.3 yd ³
Dump Bucket – 4	5.9 m ³	7.7 yd ³
Ejector Bucket	4.8 m ³	6.3 yd ³

Turning Dimensions

Outside Clearance Radius*	6638 mm	261.3 in
Inner Clearance Radius*	3291 mm	129.6 in
Axle Oscillation	10°	
Articulation Angle	42.5°	

* Clearance dimensions are for reference only.

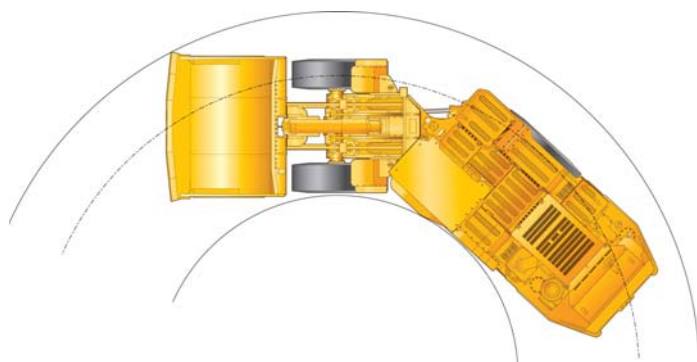

Tires

Tire Size	18.00 × 25
-----------	------------

Service Refill Capacities

Engine Crankcase with Filter	34 L	8.98 gal
Transmission	47 L	12.4 gal
Hydraulic Tank	125 L	33 gal
Cooling System	53 L	14 gal
Front Differential and Final Drives	70 L	18.5 gal
Rear Differential and Final Drives	70 L	18.5 gal
Front Differential and Final Drives (with Axle Oil Cooler)	80 L	21.1 gal
Rear Differential and Final Drives (with Axle Oil Cooler)	80 L	21.1 gal
Fuel Tank	415 L	109.7 gal
Secondary Fuel Tank (if equipped)	334 L	88.3 gal

Standards

Brakes	ISO 3450-2011, CAN-CSA 424.30-M90
Cab/FOPS	ISO 3449-2005 Level II
Cab/ROPS	ISO 3471-2008
Steering	ISO 5010-2007

R1600H Underground Mining Loader Specifications

Dimensions

All dimensions are approximate.

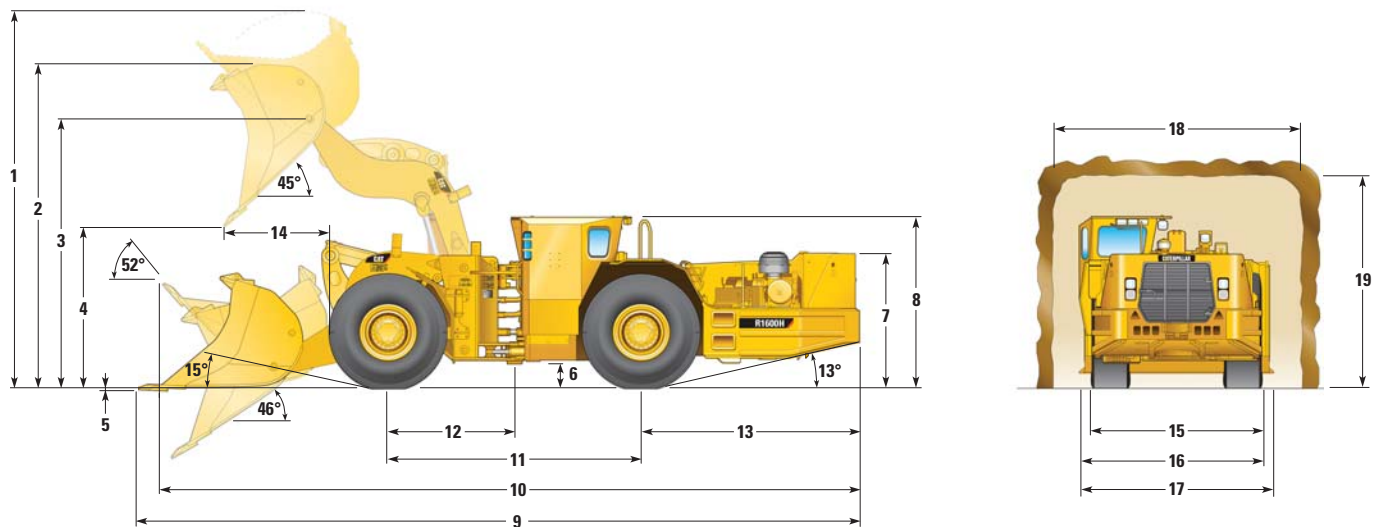

	227-4702		203-1792		227-4704		227-4703		260-5198	
	Dump Bucket		Dump Bucket		Dump Bucket		Dump Bucket		Ejector Bucket	
Bucket Capacity	4.2 m ³	5.5 yd ³	4.8 m ³	6.3 yd ³	5.6 m ³	7.3 yd ³	5.9 m ³	7.7 yd ³	4.8 m ³	6.3 yd ³
	mm	in	mm	in	mm	in	mm	in	mm	in
Bucket Width over Cutting Edge	2600	102.4	2600	102.4	2600	102.4	2900	114.2	2600	102.4
1 Height – Bucket Raised	5114	201.3	5204	204.9	5282	208.0	5242	206.4	5385	212.0
2 Height – Max Dump	4497	177.0	4497	177.0	4497	177.0	4497	177.0	4565	179.7
3 Height – Max Lift Bucket Pin	3752	147.7	3752	147.7	3752	147.7	3752	147.7	3752	147.7
4 Height – Dump Clearance at Max Lift	2311	91.0	2207	86.9	2042	80.4	2114	83.2	2120	83.5
5 Height – Digging Depth	28	1.1	39	1.5	54	2.1	45	1.8	47	1.9
6 Height – Ground Clearance	344	13.5	344	13.5	344	13.5	344	13.5	344	13.5
7 Height – Top of Hood	1890	74.4	1890	74.4	1890	74.4	1890	74.4	1890	74.4
8 Height – Top of ROPS	2400	94.5	2400	94.5	2400	94.5	2400	94.5	2400	94.5
9 Length – Overall (Digging)	9955	391.9	10 107	397.9	10 347	407.4	10 243	403.3	10 233	402.9
10 Length – Overall (Tramming)	9619	378.7	9711	382.3	9853	387.9	9790	385.4	9948	391.7
11 Length – Wheelbase	3536	139.2	3536	139.2	3536	139.2	3536	139.2	3536	139.2
12 Length – Front Axle to Hitch	1768	69.6	1768	69.6	1768	69.6	1768	69.6	1768	69.6
13 Length – Rear Axle to Bumper	3055	120.3	3055	120.3	3055	120.3	3055	120.3	3055	120.3
14 Length – Reach	1304	51.3	1408	55.4	1573	61.9	1504	59.2	1495	58.9
15 Width – Overall Tire	2404	94.6	2404	94.6	2404	94.6	2404	94.6	2404	94.6
16 Width – Machine without Bucket	2567	101.1	2567	101.1	2567	101.1	2567	101.1	2567	101.1
17 Width – Machine with Bucket	2723	107.2	2723	107.2	2723	107.2	3018	118.8	2723	107.2
18 Recommended Clearance Width	3500	137.8	3500	137.8	3500	137.8	3500	137.8	3500	137.8
19 Recommended Clearance Height	3000	118.1	3000	118.1	3000	118.1	3000	118.1	3000	118.1

R1600H Underground Mining Loader Specifications

Gradeability/Speed/Rimpull

To determine gradeability performance: Read from gross weight down to the percent of total resistance. Total resistance equals actual percent grade plus rolling resistance. As a general guide use 2% for rolling resistance in underground applications or refer to the Caterpillar Performance Handbook. From the total resistance point, read horizontally to the curve with the highest obtainable gear, then down to maximum speed. Usable rimpull will depend upon traction available and weight on drive wheels.

———— Typical Field Empty Weight
 Loaded Weight

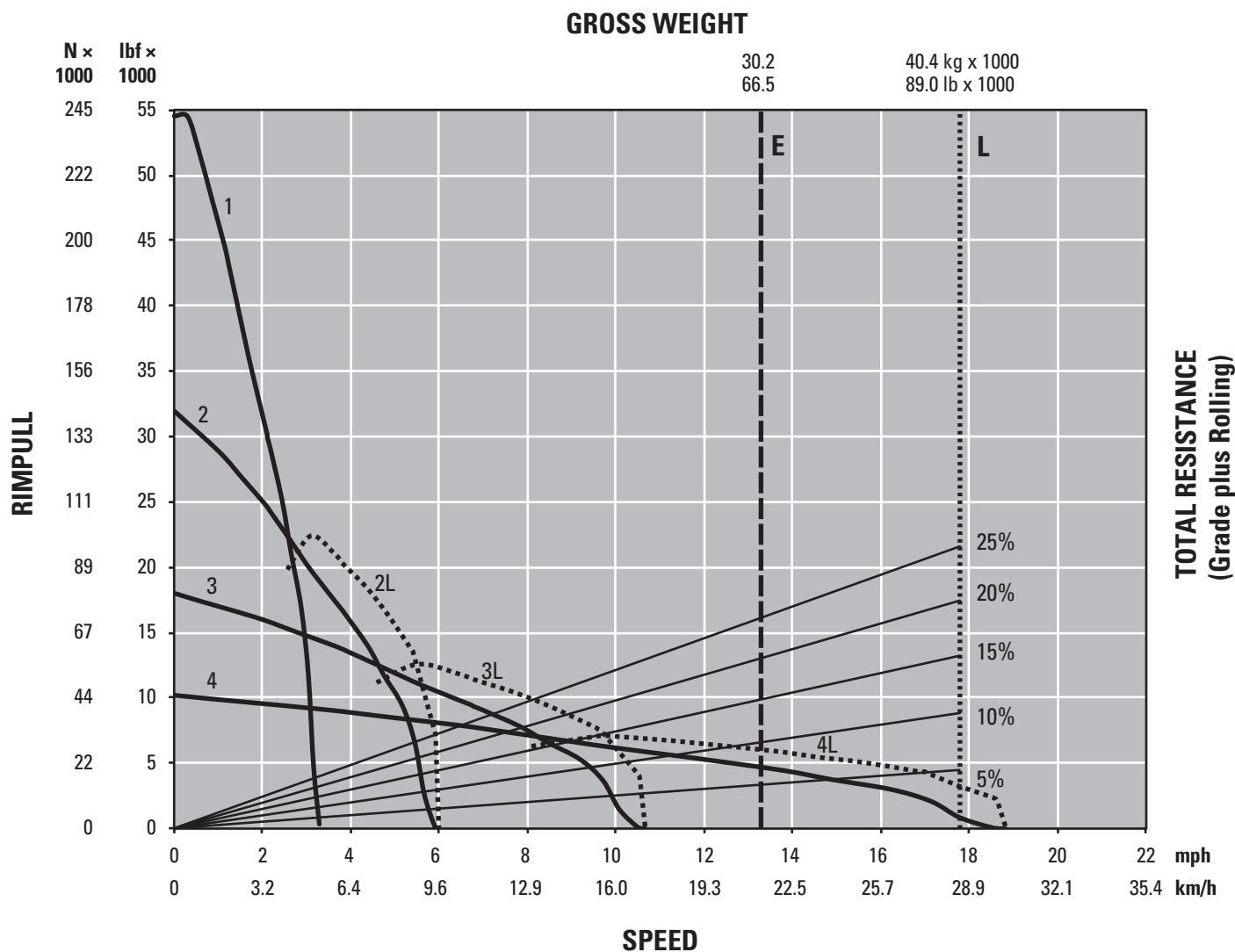

KEY

- 1 – 1st Gear
- 2 – 2nd Gear
- 2L – 2nd Gear (Lockup Clutch)
- 3 – 3rd Gear
- 3L – 3rd Gear (Lockup Clutch)
- 4 – 4th Gear
- 4L – 4th Gear (Lockup Clutch)

KEY

- E – Empty 30 150 kg (66,470 lb)
- L – Loaded 40 350 kg (88,956 lb)

R1600H Standard Equipment

Standard Equipment

Standard equipment may vary. Consult your Cat dealer for details.

ELECTRICAL

- 12V Power Supply in Cab
- Alternator, 95-amp
- Auxiliary Start Receptacle
- Battery Disconnect Switch, Ground Level
- Circuit Breaker, 80-amp
- Corrosive Protection Spray
- Diagnostic Connector
- Electric Starting, 24-volt
- Engine Shutdown Switches
 - Rear Left Hand Side
 - Rear Right Hand Side
 - Under Operator Seat
- External Lighting System, Front, Rear, Halogen Work Lights
- Low Maintenance Batteries
- Reversing Alarm
- Starting and Charging System

OPERATOR ENVIRONMENT

- Color Multi-Purpose Display (CMPD) Incorporating:
 - Battery Voltage
 - Boost Pressure
 - Brake Accumulator Oil Pressure
 - Diagnostics and System Data
 - Engine Oil Pressure
 - Event Codes, Description and Operator Response
 - Front and Rear Axle Temperatures
 - Front and Rear Brake Pressures
 - Fuel Pressure
 - Language Options
 - Monitoring System
 - Park Brake Oil Pressure
 - System Diagnostics
 - Torque Converter Temperature
 - Transmission Pressure
- Electric Horns

- Gauges
 - Engine Coolant Temperature
 - Transmission Coolant Temperature
 - Hydraulic Oil Temperature
 - Fuel Level
 - Speedometer
 - Tachometer
- Indicator Lights
 - Alert Warning Light
 - Residual Brake Pressure
 - Low Fuel Level
- Low Hydraulic Level Warning
- Open Operator Station ROPS/FOPS Structure
- Operator Presence System (Auto Park Brake)
- Pilot Hydraulic Implement Controls, Single Joystick
- Push Button Panel for Lights
- Suspension Seat with Retractable Seat Belt
- STIC Steering

POWER TRAIN

- Cat C11 ATAAC Diesel Engine with ACERT Technology, 6-Cylinder
- Brake Axle Cooling
- Electric Fuel Priming Pump
- Engine Air Intake Precleaner
- Engine Oil Filter, Remote Mounted
- Heat Shields
- Long Life Coolant
- Planetary Powershift Transmission with Automatic Shift Control, 4 Speed Forward/4 Speed Reverse
- Radiator, Cross Flow
- Rims, 5-Piece, Tubeless
- SAFR™ Full Hydraulic Enclosed Wet Multiple-Disc Brakes
- Torque Converter with Automatic Lockup Clutch
- Transmission Neutralizer with Override Switch
- Transmission Filter Drain Tap

OTHER STANDARD EQUIPMENT

- Brake Light
- Bucket Positioner, Return To Dig
- Bucket, Dump
- Cap, Radiator Manual Release
- Catalytic Exhaust Purifier/Muffler Group
- Decals, International Picto Graphics
- Engine and Transmission Belly Guards
- Fenders, Front, Rear
- Firewall
- Hydraulic Oil Cooler – Swing Out Rear Frame
- Operator and Maintenance Manual, English
- Protection Wear Bars 100 × 50 mm (4 × 2 in)
- Radiator Grill, Swing Out
- Semi Centralized Lubrication Points
- S-O-S port
 - Coolant
 - Engine Oil
 - Hydraulic Oil
 - Transmission Oil
- Swing Out Radiator Grill
- Tires and Rims: A tire must be selected from the mandatory attachments section of the machine price list. Base machine price includes a standard tubeless rim allowance only.

Optional Equipment

Optional equipment may vary. Consult your Cat dealer for details.

- Brake Release Arrangements, Includes Steering Release
 - Recovery Hook
 - Recovery Bar
- Buckets
 - Cutting Edge, Cat Weld On
 - Cutting Edge, Half Arrow, Flat
 - Ejector Bucket Installed
 - Heel Shrouds, Ejector and Dump Buckets
 - Lip Fully Welded or Tack Welded
 - Mechanically Attached Wear Plate System (MAWPS)
 - Various Sizes, Dump (4.2 m³/5.5 yd³ to 5.9 m³/7.7 yd³), Ejector (4.8 m³/6.3 yd³)
 - Wear Bars, Ejector and Dump Buckets
 - Wear Liner (4.8 m³/6.3 yd³ Dump Bucket)
- Cover, Antivandalism for Shipping
- Drawbar Attachment, Bolt-on
- Dual Fuel Tanks
- Engine Options
 - Diesel Particulate Filter (for use with VR Engine only)
 - Engine, Ventilation Reduction (VR)
 - Engine, Tier 3
- Fast Fill System
 - Coolant
 - Engine Oil
 - Fuel (Single or Dual Tanks)
 - Hydraulic Oil
 - Transmission Oil
- Fire Suppression System, Ansul
- Fluids
 - Arctic Fuel
 - Arctic Coolant
- Front Light Protectors
- Fuel System Manual Shut Off Tap
- Guard, Rear Side Quarter Window
- Hydraulic System
 - Ejector Bucket Ready
 - Alternate Implement/Pilot Control Configuration
- Idle Timer
- Lighting
 - External Lighting System, Front, Rear, LED Work Lights
- Lubrication System
 - Automatic
 - Centralized
- Mine Transfer
 - Mine Transfer Ready Rear Frame (Tack Welded)
 - Lifting Group, Mine Transfer
- Operators Station ROPS/FOPS Enclosed
 - Air Conditioning and Heater
 - Cab Pressurizer and Filter
 - Dome Light
 - Radio Ready Compartment for Radio and Speakers
- Operators Station FOPS Open
 - Removable Canopy
- Operator and Maintenance Manual
 - Chinese
 - French
 - Indonesian
 - Portuguese
 - Russian
 - Spanish
- Park Brake Switch Engagement
 - Push to Apply
 - Pull to Apply
- Payload Control System (PCS)
- Remote Control Interface (excludes Transmitter and Receiver)
 - Cattron
 - RCT
- Reversible Steering
- Ride Control System
- Rim
 - Tube Type
 - Spare (Tube or Tubeless)
- Seat Covers, Tee and Standard
- Secondary Steering System
- Service Tools
 - Recovery Bar (for use with Brake Release, Recovery Bar System)
 - Reference Parts Manual for Additional Tooling Available
- Technology
 - Command for Underground
 - Vital Information Management System (VIMS) Gen 3
- Tee Seat
- Tire Arrangements
 - Tire, 18 × R25 VSMS L-5S Bridgestone
 - Tire, 18 × 25 STMS L5S Bridgestone
- Wear Protection Bars
 - Cab/ROPS
 - Hydraulic Tank
 - Radiator
- Windows
 - Single Pane
 - Dual Pane
- NOTE: Not all features are available in all regions. See your Cat dealer for more information.

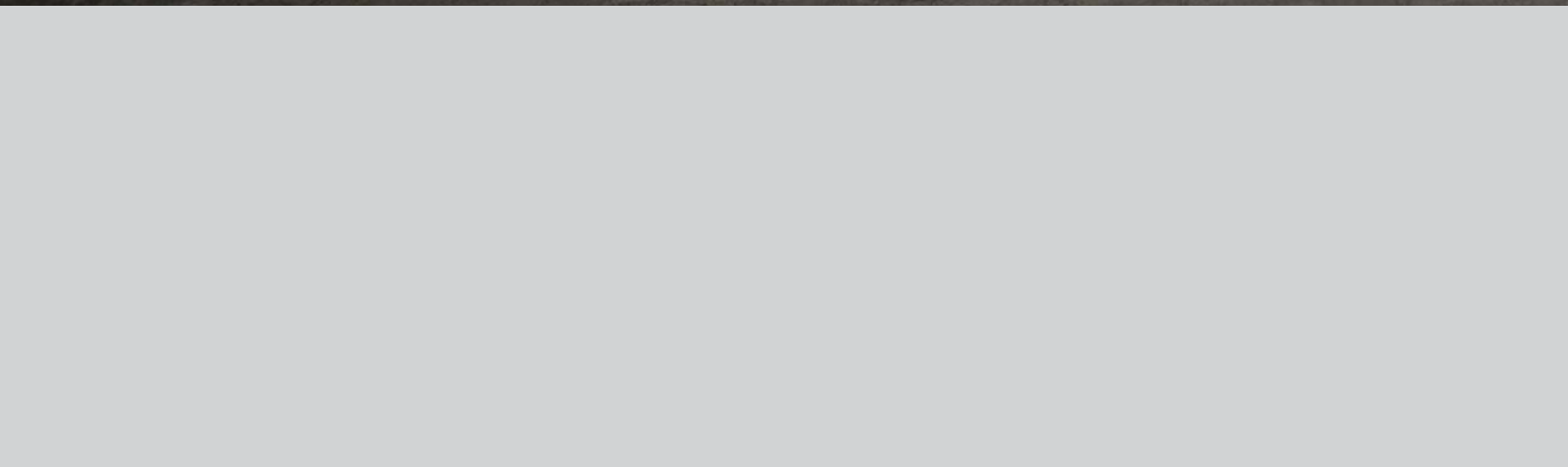



The R1600H underground loader is well matched to the AD30 underground truck for a loader and truck combination. The R1600H can easily load the AD30 truck fitted with a dump body or ejector body configuration using a standard dump bucket or if restricted by height the ejector bucket option could be used on the loader.

The AD45B underground truck can also be matched with the R1600H when a larger truck model is required.

For more complete information on Cat products, dealer services, and industry solutions, visit us on the web at www.cat.com

AEHQ7135-02 (05-2015)
Replaces AEHQ7135-01

© 2015 Caterpillar
All rights reserved

Materials and specifications are subject to change without notice. Featured machines in photos may include additional equipment. See your Cat dealer for available options.

CAT, CATERPILLAR, SAFETY.CAT.COM, their respective logos, "Caterpillar Yellow" and the "Power Edge" trade dress, as well as corporate and product identity used herein, are trademarks of Caterpillar and may not be used without permission.

